



---

# OPERATOR'S MANUAL

---

## Safety, Operation & Service Information

### EPIC® 200 Series One-Man Hole Digger

**Model:** 242H

**Form:** GOM08042001US, Version 1.3, Original Instructions

- Do not discard this manual.
- Keep manual readily available for reference during operation or when servicing product.
- Before operation, read and comprehend operator manual content.
- Customer Service: 001 507 451 5510
- Customer Service Telefax: 001 507 451 5511

*Note: There is no charge for Customer Service.*

- Internet Address: <http://www.generalequip.com>
- Email: [general@generalequip.com](mailto:general@generalequip.com)
- Mailing Address:  
General Equipment Company, 620 Alexander Dr. S.W., P.O. Box 334, Owatonna, MN 55060, USA

#### EUROPEAN CE REPRESENTATIVE

- Customer Service: (+31) 5 23 63 82 86
- Internet Address: <http://www.eurogate-international.com>
- Email: [info@eurogate-international.com](mailto:info@eurogate-international.com)
- Mailing Address: Eurogate International, Galilieistraat 6, 7701 SK Dedemsvaart, The Netherlands

Product covered by this manual complies with mandatory requirements of 2006/42/EC.

Copyright 2020, General Equipment Company, All rights reserved.



**TABLE OF CONTENTS**

1 INTRODUCTION ..... 3  
 2 INTENDED USE ..... 3  
 3 TRAINING ..... 3  
 4 SAFETY SYMBOLS ..... 3  
 5 SAFETY INSTRUCTIONS ..... 3  
 6 MACHINE SPECIFICATIONS ..... 6  
 7 STANDARD PRODUCTS & ACCESSORIES ..... 6  
 8 MACHINE SET-UP ..... 7  
 9 APPLICATION THEORY & TECHNIQUES ..... 8  
 10 OPERATING INSTRUCTIONS ..... 9  
 11 MAINTENANCE INSTRUCTIONS ..... 13  
 12 SERVICE/REPAIR INSTRUCTIONS ..... 16  
 13 TROUBLESHOOTING ..... 19  
 14 STORAGE ..... 19  
 15 END OF LIFECYCLE ..... 20  
 16 DECLARATION OF CONFORMITY ..... 20  
 17 REPLACEMENT PARTS ..... 22

- It is responsibility of owner(s) and/or operator(s) to determine no modifications and/or alterations have been made to Hole Digger. Modifications and/or alterations can lead to possibility of serious damage, injury or even death. It is responsibility of owner(s) and/or operator(s) to make this Operator Manual available for consultation during all phases of operation.
- Refer to OSHA 2207 and/or applicable updated revisions which contains all OSHA job safety, health rules and regulations (1926 and 1910) covering construction.

**CAUTION**

The concept of portable, one and two man operated, hole digging equipment has been successfully utilized for over forty years as a practical solution to many types of hole digging job requirements. The basic concept is proven and well accepted within the associated marketplaces as an alternative method to manual labor and/or larger, mounted earth drilling machinery.

Use of a Hole Digger requires strenuous work activity. This type of work activity can be considered to be greater in magnitude than that experienced with the use of many other types of both light construction and lawn and garden related equipment. This type of work activity should only be attempted by operators of adequate physical size and stature, mental awareness, and physical strength and condition.

Each operator is required to supply a resultant force that counteracts/balances and/or resists the natural torque and kickback forces generated during the hole digging process. The body parts most noticeably affected during the hole digging process are the arms, hands, wrists, shoulders, lower back and legs. The hole digging process can also produce excessive stress/strain directly to the back muscles, spinal vertebrae and many other body parts. Back related pain can be a side effect of the hole digging process. An operator with a chronic back related problem or a history of back and/or other medically related problems should not attempt to utilize the Hole Digger. Use of the Hole Digger may only aggravate this and any other medically related problem.

The torque and kickback forces generated and/or encountered correspond to natural laws of physics and are inherent to the hole digging process. They cannot be changed or totally eliminated with portable one and two man operated, hole digging equipment of this design. Proper operating positions and techniques, as outlined in this manual, can be successfully utilized to minimize the effects of the torque and kickback forces upon the human body.

Because of the diverse type of prevailing digging conditions, operator experience levels and operator physical characteristics, no warranty, guarantee, representation and/or liability is made by the manufacturer as to the absolute correctness or sufficiency of any operational procedure, operational position and/or technique. There is no absolute guarantee that an operator of any given experience level, physical size and/or physical condition will be immune to the possibility of and/or probable physical side effects of the normal hole digging process.

Each potential operator of the Hole Digger must be made aware of and assume the operational and physical liability described and/or associated with the hole digging process when utilizing the Hole Digger. Each potential operator not willing to assume the operational and physical liability described and/or associated with the hole digging process should not operate the Hole Digger. Proper levels of operator experience, skill and common sense are essential for maximizing the safe and efficient operation of the Hole Digger.

**Record Hole Digger and engine/electric motor serial numbers in spaces provided below.**

Model Number: \_\_\_\_\_

Serial Number: \_\_\_\_\_

Engine/Electric Motor Serial Number: \_\_\_\_\_

Date of Purchase: \_\_\_\_\_

Specifications and design are subject to change without notice or obligation. All specifications are general in nature and are not intended for specific application purposes. General Equipment Company reserves the right to make changes in design, engineering or specifications and to add improvements or discontinue manufacture at any time without notice or obligation. General Equipment Company and its agents accept no responsibility for variations which may be evident in actual products, specifications, pictures and descriptions contained in this publication.

**NOTICE TO OPERATORS**

IF YOU CAN NOT READ OR DO NOT FULLY UNDERSTAND THE CONTENTS OF THIS MANUAL, PLEASE CONTACT THE FACTORY FOR PROPER ASSISTANCE BEFORE ATTEMPTING TO OPERATE THIS PRODUCT.

SI TU NO PUEDES LE'ER O NO COMPRENDES EL CONTENIDO DE ESTE MANUAL FAVOR DE PONERSE EN CONTACTO CON LA FABRICA PARA ASISTENCIA-APROPIA ANTES DE INTENTAR PARA OPERAR ESTE PRODUCTO.

SOLLTEN SIE DIESE GEBRAUCHSANWEISUNG NICHT LESEN KOENNEN ODER ES NICHT VOLLKOMMEN VERSTEHEN, WENDEN SIE SICH BITTE AN DEN HERSTELLER FUER RICHTIGE HILFE EHE SIE VERSUCHEN DIESES PRODUKT ZU OPERIEREN.

SI VOUS NE LISEZ OU NE COMPRENDRE ENTIEREMENT LES MATIERES DE CE MANUEL, S'IL VOUS PLAÎT, CONTACTEZ L'USINE POUR L'ASSISTANCE APPROPRIÉE AVANT D'UTILISER LE PRODUIT.

**IMPORTANT:**

- DO NOT allow anyone to operate Hole Digger without first reading this Operator Manual and becoming familiar with Hole Digger operation.
- Manufacturer of this Hole Digger has gone to great extremes to provide owner(s) and/or operator(s) with the finest equipment available for its intended job function of digging vertical holes in unconsolidated and specific semi-consolidated earth formations. Yet, the possibility exists Hole Digger can be utilized in and/or subjected to job applications not perceived and/or anticipated by manufacturer. Such misuse and/or misapplication of Hole Digger can lead to possibility of serious damage, injury or even death.
- It is responsibility of owner(s) and/or operator(s) to determine Hole Digger is utilized and/or operated within scope of its intended job function.
- It is responsibility of owner(s) and/or operator(s) to establish, monitor and constantly upgrade all safety programs and/or practices utilized in and for operation of Hole Digger. Purpose of such programs is to provide for owner(s) and/or operator(s) safety. Operators must be instructed to recognize and avoid unsafe conditions associated with their work (29 CFR 1926.21 (b)(2)) and/or applicable updated revisions.

**OPERATOR INSTRUCTIONAL DATA SHEET**

The following undersigned operators of Hole Digger described and/or pertaining to this Operator Manual have received formal safety and operational information/instruction from undersigned owner(s)/instructor(s) in accordance to OSHA 29 CFR 1926.21 (b)(2) and/or applicable updated revisions pertaining to, but not necessarily limited to the:

1. READING, COMPREHENSION AND ACKNOWLEDGEMENT OF MATERIAL COMPRISING ENTIRE CONTENTS OF APPLICABLE OPERATOR MANUAL.
2. FORMALIZED OPERATOR SAFETY PROGRAM TO BE DEvised BY OWNER OF HOLE DIGGER IN CONJUNCTION WITH CONTENTS OF APPLICABLE OPERATOR MANUAL FOR HOLE DIGGER.
3. OSHA RULES AND REGULATIONS RESEARCHED FOR AND/OR BY OWNER OF HOLE DIGGER AND DEEMED APPLICABLE TO SAFE AND PROPER USE AND/OR OPERATION OF HOLE DIGGER FOR ANY SPECIFIC JOB APPLICATION.
4. LOCAL LAWS, REGULATIONS AND CUSTOMS RESEARCHED FOR AND/OR BY OWNER OF HOLE DIGGER AND DEEMED APPLICABLE TO SAFE AND PROPER USE AND/OR OPERATION OF HOLE DIGGER FOR ANY SPECIFIC JOB APPLICATION.
5. FORMALIZED MAINTENANCE PROGRAM FOR HOLE DIGGER TO BE DEvised BY OWNER OF HOLE DIGGER IN ACCORDANCE WITH, BUT NOT NECESSARILY LIMITED TO, SPECIFICATIONS, GUIDELINES AND OPERATIONAL INFORMATION CONTAINED IN APPLICABLE OPERATOR MANUAL.
6. COMPREHENSIVE OPERATIONAL INSTRUCTIONS FOR CORRECT AND PROPER USE OF HOLE DIGGER AS PER CONTENTS OF APPLICABLE OPERATOR MANUAL.

_____	Operator	_____	Owner/Instructor	_____	Date
_____	Operator	_____	Owner/Instructor	_____	Date
_____	Operator	_____	Owner/Instructor	_____	Date
_____	Operator	_____	Owner/Instructor	_____	Date
_____	Operator	_____	Owner/Instructor	_____	Date
_____	Operator	_____	Owner/Instructor	_____	Date
_____	Operator	_____	Owner/Instructor	_____	Date
_____	Operator	_____	Owner/Instructor	_____	Date
_____	Operator	_____	Owner/Instructor	_____	Date
_____	Operator	_____	Owner/Instructor	_____	Date
_____	Operator	_____	Owner/Instructor	_____	Date
_____	Operator	_____	Owner/Instructor	_____	Date
_____	Operator	_____	Owner/Instructor	_____	Date
_____	Operator	_____	Owner/Instructor	_____	Date
_____	Operator	_____	Owner/Instructor	_____	Date
_____	Operator	_____	Owner/Instructor	_____	Date

**NOTE:** INSERT COPIES OF THIS PAGE WITHIN OPERATOR'S MANUAL IF SPACE FOR ADDITIONAL OPERATORS IS REQUIRED.

## 1 INTRODUCTION

Congratulations on your decision to purchase a General Equipment light construction product. From our humble beginnings in 1955, it has been a continuing objective of General Equipment Company to manufacture equipment that delivers uncompromising value, service life and investment return. Because of this continuous commitment for excellence, many products bearing the General name actually set the standard by which competitive products are judged.

When you purchased this product, you also gained access to a team of dedicated, knowledgeable, support personnel that stand willing and ready to provide field support assistance. Our team of sales representatives and in-house factory personnel are available to ensure each General product delivers the intended performance and product safety you expect. Our personnel can readily answer your questions or concerns regarding proper applications, service requirements and warranty related problems.

If you have any questions or concerns about this product, please feel free to contact our European Representative or Customer Service Department during normal business hours using the contact information located on the front cover of this manual. There is no charge for this service.

Sincerely,  
The General Equipment Team

## 2 INTENDED USE

The Hole Digger is intended for use in digging holes outdoors in a variety of soil conditions from soft loams to hard-packed caliche. The machine is operated by one adult of proper operator experience/skill/common sense, height, weight, strength and physical condition. Minors should never be allowed to operate the Hole Digger.

Hole Digger is classified as a low cost, hand held, low horsepower, portable type machine. The number of practical and/or suitable job applications for this type equipment is limited. Particular job application variables and operator experience/skill/common sense may require a different type machine, method and/or process to properly complete job efficiently and safely. Contact Customer Service Department for specific information regarding suitable job applications, job sites, soil conditions and operator experience/skill/common sense recommendations for Hole Digger BEFORE utilization.

Never exceed the recommended capacities of Hole Digger. Refer to BEFORE OPERATING and SPECIFICATIONS sections in this manual for more detailed information. Always utilize correct auger and auger extension series designed for use with Hole Digger. DO NOT use ice augers to dig earth. Use of an incorrect auger or auger series can result in property damage and/or personal injury.

### OPERATIONAL DISCLAIMER

The manufacturer of this Hole Digger makes no warranty or guarantee it is merchantable and/or suitable for a specific job application and that it will have the power required to dig a specific diameter hole down to a specific depth in a specific soil classification.

## 3 TRAINING

Develop a comprehensive program for safe Hole Digger operation by owner(s) and/or operator(s). Program will include, but is not limited to: instructional operation requirements, applicable OSHA requirements, local laws and regulations, job site safety plus Hole Digger maintenance. Constantly examine and upgrade program to guarantee owner(s) and/or operator(s) safety. Each operator must be fully instructed regarding specifics of this safety program.

## 4 SAFETY SYMBOLS

### SAFETY ALERT SYMBOL & SIGNAL WORDS

The safety alert "general warning" symbol indicates a potential personal injury hazard. A signal word (DANGER, WARNING, or CAUTION) is used with the alert symbol to designate the degree or level of hazard seriousness. Other safety symbols may be used to represent the type of hazard in combination with "general warning" symbol, in highlighted boxes, or individually.

### DANGER:

Indicates a hazard with a high level of risk which, if not voided, will result in death or serious injury.

### WARNING:

Indicates a hazard with a medium level of risk which, if not avoided, could result in death or serious injury.

### CAUTION:

Indicates a hazard with a low level of risk which, if not avoided, could result in minor or moderate injury.

The following safety alert symbols identify important safety messages in this manual. When you see these symbols, be alert to the possibility of personal injury and carefully read the message that follows.

### SAFETY SYMBOLS & MEANINGS

Symbol	Meaning	Symbol	Meaning
	Action Required		General Warning
	Read Manual		Warning, Flammable Material
	Wear Ear Protection		Warning, Explosive Material
	Wear Eye Protection		Warning, Toxic Material
	Wear Protective Gloves		Warning, Electricity
	Wear Safety Shoes		Warning, Body Entrapment
	No Open Flame		Warning, Rotating Parts
	No Smoking		Warning, Hot Surface
	No Active Mobile Phone		Warning, Floor Level Obstacle
	No Food Or Drink		Warning, Drop Off
	No Trash Containers		Warning, Slippery Surface

## 5 SAFETY INSTRUCTIONS



### WARNING

- These safety instructions provide guidelines to promote safety and efficiency with the Hole Digger.
- No warranty, guarantee or representation is made by manufacturer as to absolute correctness or sufficiency of any information or statement.
- Safety instructions are intended to deal with common practices and conditions encountered in use of Hole Digger and are not intended to be all inclusive.
- Not following instructions in this manual can result in property damage, personal injury and/or death.



### DANGER



- This product can expose you to chemicals including greases, lubrication oils, silica dusts and asbestos which are known to the State of California to cause cancer and carbon monoxide (if gasoline engine driven) which is known to cause birth defects or other reproductive harm. For more information: [www.P65Warnings.ca.gov](http://www.P65Warnings.ca.gov)

**SPARK ARRESTER DISCLAIMER**

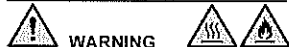

**WARNING**

- DO NOT operate Hole Digger on any forest covered, brush covered, or grass covered, unimproved land unless an approved spark arrester is installed on the muffler. The spark arrester must be maintained in proper working order by the owner and/or operator. In the State of California, the above is required by law. Other states may have similar laws. Laws will apply on US Federal lands. Laws will vary with use in specific countries.

**NOTE:** For SDS (Safety Data Sheets) pertaining to materials such as oils, lubricants and/or solvents used in conjunction with Hole Digger, visit the LIBRARY section of our website at [www.generalequip.com](http://www.generalequip.com).

**BEFORE OPERATING**



1. BEFORE operating the Hole Digger, read this manual plus applicable safety/operational information supplied by engine manufacturer to familiarize each operator with correct operating procedures.
2. Visually inspect Hole Digger per MAINTENANCE INSTRUCTIONS STEPS 4 through 15 of this manual.
3. Determine Hole Digger is in original, factory configuration and has not been modified in any manner. If questions arise about possible modifications, contact the European Representative or Customer Service Department BEFORE utilization. There is no charge for this service.
4. Always start and stop Hole Digger according to instructions to minimize possibility of unexpected or uncontrolled auger rotation. Know how to stop unit in an emergency.

**Physical Exertion/Body Strain**

Operating the Hole Digger requires proper physical stamina, mental alertness and is strenuous. Operator must be in proper physical condition, mental health and not under the influence of any substance (drugs, alcohol, etc.) which might impair vision, dexterity or judgement. Take work breaks to maintain stamina and alertness. If you have condition(s) that might be aggravated by strenuous work, check with doctor BEFORE operating.

**Operator**

Operator must be of adequate height for any given operating configuration and operator handle must remain below their shoulder sockets. DO NOT operate Hole Digger if this condition is not satisfied. Hole Digger requires operator to be of adequate height, weight and strength to maximize digging efficiency and minimize possibility of personal injury.

**Vibration**

Prolonged use of Hole Digger (or other, similar machines) exposes operator to vibrations which may produce Whitefinger Disease (Raynaud's Phenomenon) reducing hand's ability to feel and regulate temperature, produce numbness and burning sensations plus may cause nerve, circulation damage and tissue necrosis. Continuous and regular users should closely monitor condition of hands and fingers. After each period of use, exercise to restore normal blood circulation. If any symptoms appear, seek medical advice immediately.

**Noise**

Hole Digger and actual digging process creates exposure to high noise emission levels that can result in hearing loss or damage. Hearing protection is required while operating or when near operating equipment. Continuous and regular operators should have hearing checked regularly.

**Poisonous Gas**

Hole Digger is powered by a gasoline engine which produces Carbon Monoxide fumes during combustion process. Carbon Monoxide fumes are poisonous. If Hole Digger is operated in closed area (indoors or outdoors), determine if supplemental ventilation is required to minimize potential effects of Carbon Monoxide to operator. Follow all current OSHA regulations for ventilation.

**Clothing**

Clothing must be sturdy, snug fitting, but allow complete freedom of movement. Never wear loose fitting jackets, scarves, neckties, jewelry, flared or cuffed pants or anything that could become caught on controls or moving parts. Properly secure eyeglasses, hearing aid devices and other medical related

devices. Wear long pants to protect legs. Protect hands and improve grip with heavy duty, nonslip gloves. Wear and properly lace sturdy boots with nonslip soles. Steel-toed safety shoes are mandatory. Wear approved safety hard hat where there is danger of head injuries.

**Flying Debris**

Hole digging process can result in flying debris. Eye protection and appropriate safety apparel is required when near or operating Hole Digger. DO NOT operate unit with onlookers or animals close by.

**Burns**

An engine muffler can become hot. Remain clear of and DO NOT touch a hot muffler or heat shield.

**Auger Entrapment**

Auger is not shielded. Keep body and all foreign objects clear of rotating auger.

**BACK CARE & PROPER LIFTING PROCEDURES**

Operator will be required to lift Hole Digger auger/auger extension repetitively as demanded by specific job applications. When lifting, one person is required. Utilize proper lifting techniques to minimize fatigue and back-related injuries.

**Back Anatomy**

The human body is supported by the spinal column consisting of thirty bones called vertebrae, all linked and supported by a series of muscles. Pads called discs separate each vertebrae, acting as cushions to pressure from external forces. Spinal column is wrapped by nerve system with three sections that require being kept in natural alignment to prevent discomfort:

Cervical: From base of neck to brain.  
Thoracic: From middle to lower back.  
Lumbar: From lower back to buttocks area.

**Back Care Preventative Measures**

Most occupational physicians agree on several "universal" preventative measures an operator should follow to help lower risk of back-related injuries:

1. Maintain proper body weight.
2. Eliminate/reduce use of tobacco. Smoking reduces oxygen supply and nutrients to discs cushioning vertebrae.
3. Develop a consistent exercise routine.
4. Maintain good posture while walking or sitting.
5. Watch how you twist/bend your body. Twisting/bending incorrectly can exert too much pressure on discs and vertebrae.
6. Use firm footing, keep intended path clear before carrying Hole Digger.
7. Always use proper lifting techniques as described below.

**PROPER LIFTING PROCEDURES**

The following are guidelines for properly lifting Hole digger and auger/auger extension from hole and are not intended to be all inclusive. Plan your path and make sure there are no obstructions or tripping hazards. Consider how you will set the load. The spinal column is a very sensitive mechanism. At any given time, improper lifting procedures can cause damage that can lead to injury.

1. Position feet a comfortable distance (shoulder width) apart to help provide necessary balance.
2. Tighten stomach muscles by pulling in your stomach. Keep back as straight as possible to keep spine, back muscles/ligaments in alignment.
3. Bend at hips and knees as much as possible.
4. Start lifting Hole Digger by thrusting feet while lifting as much as possible with leg muscles. Use smooth movements.
5. Once Hole Digger is lifted, keep it close as possible to the body. Avoid turning at waist. To turn, pivot entire body.
6. Keep shoulders, hips and feet pointed in same direction.

**IMPORTANT:** Use firm footing, keep intended path clear before carrying Hole Digger.

**TRANSPORTATION**



- Hole Digger is designed for one operator to transport it by the operator handle to, while on, and from job site.
- When transporting Hole Digger in/on motor vehicle, gasoline tank breather vent (if so equipped) must be completely closed to eliminate fuel seepage.
- To minimize damage to Hole Digger, transport in vehicle to job site with auger disconnected and operator handle level with transport surface. This prevents crankcase oil entering combustion chamber causing hydraulic lock up.
- DO NOT allow operator handle to contact augers, shovels, or other sharp/abrasive objects during transit or drop Hole Digger to prevent damage to unit.
- All equipment must be secured in/on vehicles with suitable strapping or tie downs.
- Personnel should not be transported in same compartment as equipment and fuel supplies. Consult applicable OSHA regulations for specific information.



**CAUTION**

- Improperly secured Hole Digger and related accessories can fall from moving vehicle and result in property damage and/or personal injury.

**DETERMINATION OF POTENTIAL SUBSURFACE HAZARDS IN PROPOSED DIGGING LOCATION(S)**



Hole Digger operator handle and throttle control are constructed of metallic and a non-metallic, composite material and does not guarantee operator will be properly insulated from contact with charged electrical cables. Hole Digger and related accessories are not classified as insulated.

Hole Digger is not sealed or insulated. DO NOT operate Hole Digger in an explosive atmosphere or near combustible materials. Refer to current OSHA rules and regulations.



**WARNING**



BEFORE attempting to dig any holes, identify/mark all potential subsurface hazards in proposed digging locations(s). Potential subsurface hazards may include, but may not be limited to the following:

- Rocks and roots of any size.
- Differences and/or variances in specific soil classifications.
- Buried garbage/other debris.
- Buried pressurized pipelines (e.g. natural gas, propane, etc.)
- Buried electrical cables.



**DANGER**



- Always assume digging location contains buried underground obstructions.
- BEFORE attempting to dig any holes in proposed location(s), call 811 and/or visit [www.Call811.com](http://www.Call811.com).
- Contact appropriate agencies to determine exact location(s) of all buried pipelines, powerlines and material debris.
- Many utilities and other agencies will perform these tasks at minimal charge or at no cost. Have all subsurface hazards marked for easy recognition.
- Direct contact with these and other subsurface hazards can result in property damage and/or personal injury through such things as electrocution and/or explosion.

**DETERMINATION OF POTENTIAL ABOVE SURFACE HAZARDS IN PROPOSED DIGGING LOCATION(S)**



Normal Hole Digger use is on level ground. Avoid other terrains which can be dangerous. Special care must be exercised on overgrown, slippery, and/or difficult/uneven terrain. Watch for surface irregularities. Remove any trip/fall hazard, grass or other overgrowth BEFORE operating Hole Digger. Operate only when/where visibility and light are adequate for job at hand. Keep proper footing and balance at all times. Engine/engine muffler can become extremely hot with potential to burn operator and/or ignite dried materials such as leaves, grass, etc. Remove such materials where digging with or placing Hole Digger.

**OPERATIONAL HAZARDS UNDERSTANDING KICKBACK**



Torque and kickback generated by digging process is common with portable, one-man hole diggers. Hole Digger engine torque is transmitted and multiplied by transmission to auger. When auger contacts a buried obstruction, left side of operator handle is "thrust" towards operator in a sharp, sudden, counter-clockwise rotation. "Thrusting" force is called kickback and varies depending on speed of handle movement. Kickback force can have magnitude to "throw" operator from Hole Digger and/or inflict damage to hands, arms, and other upper body parts.

**Preventive Measures:**

- Operator must maintain physical and mental alertness. Be prepared for unexpected auger contact with buried tree roots, rocks, etc., and be capable to sense level of machine control they have.
- DO NOT operate Hole Digger on jobsite where kickback forces can allow body parts to come in direct contact with vertical wall, foundation or other support type structures. Maintain a safe and reasonable distance from these structures.
- Maintaining proper operating stances and applying reactive "body english" is one of the most IMPORTANT and EFFECTIVE procedures to control kickback. Refer to OPERATOR STANCES in OPERATING INSTRUCTIONS section of this manual for more information.
- "Spinning" about axis is caused by improper engine throttle control adjustment. Refer to MAGURA® THROTTLE CONTROL MAINTENANCE PROGRAM in MAINTENANCE INSTRUCTIONS section of this manual to correct situation BEFORE placing machine back into service.



**CAUTION**

- Always assume every digging site can include some form of buried obstruction. Always be prepared for unexpected auger contact with buried tree roots, rocks, etc.
- Under certain operating conditions, striking a buried obstruction can produce a severe and/or sudden kickback force to hip and/or leg areas.
- Force can have magnitude to "throw" operator from Hole Digger.
- Failure to properly accommodate this phenomenon can result in property damage and/or personal injury.



**WARNING**



If, during hole digging process, operator loses full control of Hole Digger for any reason, the following procedure is suggested:

- As a general rule, as soon as operator realizes they are in process of losing control of Hole Digger, they should "push" themselves free and clear from operator handle.
- Procedure requires operator fully comprehends they are losing control of Hole Digger and to react accordingly with appropriate body movement.
- Improper reactions to this phenomenon can result in property damage and/or personal injury.



**WARNING**

- A Hole Digger with improperly maintained engine throttle control will "spin" about its axis when operator loses full control.
- In event of this occurrence, do not attempt to stop engine by grasping rotating operator handle.
- DO NOT introduce any foreign object in an attempt to stop and/or block rotating handle. Instead, allow engine to exhaust its fuel supply.
- Determine that all components of engine throttle control assembly allow for proper function before attempting to further utilize Hole Digger.

**MINIMIZING KICKBACK FROM A DESIGN STANDPOINT**

1. Hole Digger features the widest operator handle of any machine of its type and/or class. Handle is biomechanically positioned to enhance control, allowing operator to exert "body english" against torque and kickback forces generated by digging process.
2. Hole Digger features an operator handle with an antivibration PVC coating and handle mounts that enhance control and help dampen vibration, torque and kickback experienced by operator during digging process.
3. Hole Digger utilizes a twist grip throttle control. Throttle control was selected over other configurations (for operator handle configuration utilized and specific digging power) to allow operator to wrap his/her thumb and forefinger around for effective maximum strength in his/her right hand. Design provides greater operator machine control when counteracting torque and kickback forces during digging process.
4. Hole Digger is designed to utilize General Equipment Company PN 2121 auger pin for auger retention to transmission driveshaft. Pin is not intended to shear and absorb kickback related forces when auger comes in sudden contact with buried object.
5. Auger pin is utilized for the following reasons:
  - a. Pin shear would result in extensive physical damage to driveshaft and auger drive hub.
  - b. Potentially unknown/large pin quantity could be required to complete digging of any specific hole even if physical damage to Hole Digger could be eliminated and/or minimized.
  - c. Even if replacement auger pin costs are not a factor, resulting productivity produced by actual process would not be acceptable by industry and/or social standards for Hole Digger.
  - d. Given infinite number of potential operators and methods utilized during digging process, it is impossible to design and supply specific auger pins to shear at a specific torque value and produce acceptable operational results for Hole Digger.
  - e. Given infinite number of potential soil conditions, auger diameter, auger boring head condition, digging depth, mechanical operating conditions, operators and operator methods encountered during digging process, it is impossible to design and supply specific auger pins to shear at a specific torque value and produce acceptable operational results for Hole Digger.
6. For comparison purposes, portable electric screwdrivers and drills can utilize a torque limiting or clutch device to allow drill chuck to slip at a limited number of specific torque values. For a Hole Digger, such a device would make the Hole Digger useless due to infinite number of potential operating configurations required and inability to design specific components to meet requirements of each operating configuration.
7. Portable screwdrivers and drills are separate tools designed for different and specific job applications. The drilling process has different requirements than the fastening process for screwdrivers. Portable electric screwdriver and drill operational characteristics cannot be confused and/or substituted for Hole Digger operational characteristics.

**6 MACHINE SPECIFICATIONS**

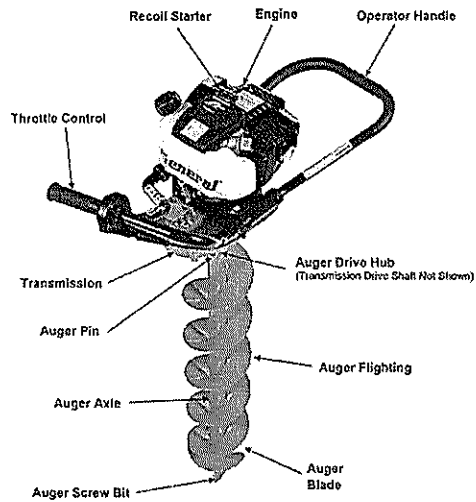

FIGURE 1

ENGINE TYPE	Honda GX35
HIGH SPEED	9000 RPM (No Load)
IDLE SPEED	2900 RPM
SPARK PLUG GAP	.030 inch (.762 mm)
FUEL	Unleaded, "regular" grade gasoline (RON 87). Consult engine manufacturer supplied materials for specific information.
FUEL TANK CAPACITY	22 US ounces (0.64 L)
TRANSMISSION TYPE	Enclosed, spur geared, double reduction
REDUCTION RATIO	42.5 to 1
LUBRICANT CAPACITY	8 US ounces (224 g)
LUBRICANT SPECIFICATION	High temperature transmission grease containing an extreme pressure (EP) additive.
CLUTCH	3 inch (76 mm) diameter, automatic type centrifugal.
MACHINE WEIGHT	28 lbs (13.0 Kg) (less auger)
AUGER CAPACITY	2 inch (50.8 mm) diameter up to and including 8 inch (203 mm) diameter. Refer to DIGGING OPERATION section in this manual for specific information.
OPERATING ENVIRONMENTS	Non-hazardous type locations.
REQUIRED NUMBER OF OPERATORS	1

**NOISE & VIBRATION EMISSIONS**

Description	North America	Europe
Model	242H	
Noise Level	85 db	
Vibration Level	51 m/s <sup>2</sup>	

**7 STANDARD PRODUCT & ACCESSORIES**

Refer to FIGURE 1 for overview description of standard components included in machine. Included in shipment for Hole Digger should be the following:

- 1 each, engine/transmission assembly
- 1 each, auger pin
- 1 each, bottle of engine oil
- 1 each, operator manual
- 1 each, applicable engine manual
- 1 each, final inspection form

**ACCESSORIES**

**NOTE:** All augers, extensions, blades and screw bits are for use in general purpose projects for a variety of soil conditions unless otherwise specified. All auger and auger extension drive connections are 1 inch (25 mm) diameter. Digging depth for all augers is 30 inch (762 mm) and auger extension is 15 inch (381 mm).

	Part #	Description	Cutting Diameter	Weight (in lbs)
	2350-2E	2.25 inch (57 mm) Auger OD	2.50 inch (64 mm)	8.0
	2350-3E	3.25 inch (83 mm) Auger OD	3.50 inch (89 mm)	9.0
	2350-4E	4 inch (102 mm) Auger OD	5.2 inch (133 mm)	12.0
	2350-6E	6 inch (152 mm) Auger OD	7.5 inch (191 mm)	14.0
	2350-8E	8 inch (203mm) Auger OD	9.5 inch (241 mm)	18.0
		2350-15X	No Flighting Auger Extension	NA
	E244PAK3	4 inch (102 mm) Auger Blade	NA	0.5
	E246PAK3	6 inch (152 mm) Auger Blade	NA	0.8
	E248PAK3	8 inch (203 mm) Auger Blade	NA	1.1
	P302PAK2	Auger Screw Bit 2350-3E ONLY.	NA	1.6
	P801PAK3	Auger Screw Bit, 2350-2E ONLY.	NA	3.0
	SB26PAK3	Auger Screw Bit, all other augers.	NA	4.2
	2121PAK3	Auger Pin	NA	0.4

**8 MACHINE SET-UP**



Open shipping carton immediately upon receipt. Remove Hole Digger from carton. Visually inspect contents of carton for freight damage and/or missing parts. If shipping damage is evident, contact delivering carrier immediately to arrange for an inspection of damage by their claims representative. **DO NOT DESTROY OR DISCARD SHIPPING CARTON UNTIL INSTRUCTED BY AUTHORIZED REPRESENTATIVE OF CARRIER OR FACTORY.** If missing parts are detected, notify your dealer who will assist you in obtaining them.

**ASSEMBLY**

Hole Digger is shipped from factory completely assembled. The transmission is lubricated at the factory and will not require further servicing prior to initial usage.

1. Visually inspect throttle control, throttle cable assembly and carburetor for signs of damage. Rotate throttle control to determine carburetor spring allows carburetor throttle lever to travel from its low to high speed position and back again without any restriction and/or binding.
2. Check all fasteners for security, tighten as required.



**WARNING**

- Determine all components of engine throttle control assembly allow for proper function.
- Throttle lever of carburetor must return engine to idle speed, as stated in MACHINE SET-UP section of this manual, when twist grip throttle is released by operator.
- If proper function does not occur, contact your dealer or customer service department for specific information to correct the situation.
- **DO NOT** operate Hole Digger until improper function has been corrected.
- An improperly functioning throttle control can result in property damage and/or personal injury.

>>>> BEFORE STARTING ENGINE <<<<



**FILLING ENGINE CRANKCASE WITH OIL**

Tools Required:

- 1 each, small, clean funnel with a flexible extension spout

Fill engine crankcase with oil on level working platform of appropriate size and height. As an alternative, transmission driveshaft can be securely mounted in suitable bench vise.

1. Wipe any dust/dirt from crankcase dipstick/filler plug area. Remove dipstick/filler plug.
2. Using funnel, add oil to engine crankcase. For proper classifications and/or amount, consult material supplied by engine manufacturer for specific information.
3. Replace dipstick/filler plug and tighten. Wipe off any excess spilled oil. Properly dispose of spilled oil/rags per international and local regulations.
4. Consult material supplied by engine manufacturer for other service related information including oil change interval. **DO NOT** operate Hole Digger unless proper oil level is maintained. Engine damage can result.

**FILLING ENGINE FUEL TANK**



Tools Required:

- 1 each, small, clean funnel.



**CAUTION**

- Never mix oil with gasoline for use in a 4 cycle engine. Damage to engine can result. Four cycle engines do not utilize oil mixed with gasoline for lubrication purposes.

BEFORE operating Hole Digger refer to MACHINE SPECIFICATIONS section in this manual and engine manufacturer supplied materials for information regarding engine fuel, fueling and lubrication requirements.

1. Use extreme caution handling gasoline. Always use UL, CSA or UN marked, European ADR regulation approved container for storage and transportation of fuel. Shut engine off and allow to cool before fueling. Never remove fuel tank filler cap or fill fuel tank while engine is running. Never operate engine without fuel tank filler cap. Select bare ground for fueling and move at least 10 feet (3.05 M) from fueling spot before starting engine.
2. Carefully clean filler cap and surrounding area to prevent dirt/debris falling into fuel tank.
3. Fill fuel tank with fresh, clean, unleaded automotive gasoline. Leaded "regular" grade gasoline is acceptable substitute. **DO NOT USE GASOLINE CONTAINING METHANOL (WOOD ALCOHOL).** Gasoline containing maximum 10 percent ethanol/grain alcohol (sometimes referred to as Gasohol) may be used but requires special care when storing engine for extended periods.



NOTE: DO NOT use gasoline left over from previous season for easier engine start-up and prevent poor engine performance.

- DO NOT completely fill tank. Fill tank to within 1/4 inch (6.4 mm) to 1/2 inch (13 mm) of tank top to allow for fuel expansion. Replace filler cap. Wipe any fuel spillage and oil if leak is detected from engine and Hole Digger BEFORE operating engine. DO NOT operate engine until leak is fixed plus, fuel and oil are wiped away. Properly dispose of any fuel or oil wiped from machine/rags per international and local regulations. DO NOT allow fuel or oil to get on clothing. Change clothes immediately if this happens.

**DANGER**

- DO NOT smoke near fuel tank.
- DO NOT fill fuel tank with engine running or if it is hot.
- Allow ample time between each refueling for engine to cool.
- An ignition source in close proximity to fuel tank can be the source of an explosion, resulting in property damage and/or personal injury.
- Consult material supplied by engine manufacturer for information relative to proper fueling procedures.

## 9 APPLICATION THEORY & TECHNIQUES



The Hole Digger operates on principle of accessory augers attached to the transmission drive shaft to rotate and dig holes in a variety of soil types. The combination of auger diameter, blade, screw bit, soil type and down pressure supplied by operators will affect the hole digging rate.

Hole digging process is directly controlled by:

- Soil type.
- Auger boring head design and diameter selected.
- When required, sufficient application and/or reduction of machine weight and/or down force provided by operators to assist auger soil penetration.
- No two soil types are exactly alike, no two holes can be dug by exact same method, overall operator feed rates vary. The hole digging process, along with operator experience, skill and common sense, suggests hole digging is a matter of trial and error and directly determines overall success of the job application.

### HOLE DIGGING TECHNIQUES

- Normal Hole Digger operation runs engine at full, governed speed allowing centrifugal clutch to become firmly engaged. Technique transmits more usable power to auger, increasing productivity and reducing component wear. For any soil condition, allow auger to dig at rate most comfortable to operators, but not cause centrifugal clutch to overload and slip.

NOTE: Hole Digger is equipped with a centrifugal clutch assembly within the transmission. The clutch assembly is designed to ALWAYS slip (NOT DISENGAGE) when overloaded or if auger contacts buried obstruction. When slipping, clutch still transmits a specific amount of torque to auger. Response time for clutch to react to overload condition is directly proportional to rotational speed. With higher rotational speeds (RPM) of clutch at time of overload, it takes more time for clutch to react and actually slip.

**CAUTION**

- Improper operating procedure can allow auger to "bind" and/or "bury" itself in the hole.
- This is usually the result of allowing auger to feed at an excessive rate. Phenomenon is also characteristic of digging with smaller diameter (2 to 4 inch) augers.
- In this condition, Hole Digger is not capable of transmitting ample power to "free" auger.
- DO NOT continue to overload and slip centrifugal clutch assembly.

- In general, pressing down on operator handle is not required to initiate and/or sustain the digging process. In most moderate density soils, auger dig rates will not cause centrifugal clutch to overload and slip. In most soft, low density soils (sandy, etc.), it may be necessary to hold up on operator handle to reduce auger dig rate due to tendency of any auger design to cause centrifugal clutch to overload and slip. In most hard, high density soils (hard clay, etc.), it may be necessary to press down on operator handle to establish and maintain acceptable dig rates.
- Some soil conditions may require more power to dig than machine is capable of delivering for a given auger diameter. To minimize problem, apply suitable down force by operator and use augers with new screw bits and blades. DO NOT use more than one operator to apply down force. If it is felt more than two operators are required to apply down force, STOP and contact Customer Service Department for operational recommendations.
- When digging in areas filled with known, buried obstructions such as tree roots, rocks and other debris, operate Hole Digger at less than full (an intermediate) speed for more rapid release of centrifugal clutch when obstruction is encountered. This is an industry wide operating procedure.
- When digging in areas filled with small tree roots, small rocks or other buried obstructions, allow auger blade to "chip away" at obstruction until auger can pass by (by working object loose) or go through it (as in penetrating tree roots). Technique usually involves holding up on operator handles using minimal auger feed rate. Many times, size and nature of buried object will prevent auger from passing by or going through it. Instead, remove buried object with shovel or other suitable tool and proceed to dig to desired depth using Hole Digger.

**CAUTION**

- Some job applications may encounter buried obstructions too massive in size or soil classifications too compacted to allow use of machine the size and/or with operating limitations of Hole Digger.
- Utilization of Hole Digger on these work sites can cause property damage and/or personal injury.
- Exercise proper common sense by selecting proper size and/or type equipment for the job application.

- In most soil conditions, the auger will retract with less effort if allowed to rotate at slow speed. This procedure, however, will leave more loose soil at bottom of hole. To minimize amount of loose soil remaining at bottom of hole, stop rotation before retracting auger.
- When restarting a Hole Digger with auger in a partially or completely dug hole extra caution is required. The throttle control can be advanced beyond idle speed before operator can exercise proper control of Hole Digger. The accepted procedure (when not using non-flighted auger extension) is to first remove unit from hole and restart engine per STARTING ENGINE WITH AUGER ATTACHED in OPERATING INSTRUCTIONS section of this manual. Return unit to hole with engine at idle speed and complete hole to desired depth.

**CAUTION**

- Restarting engine with auger in partially or completely dug hole requires higher degree of operator experience, skill and common sense over introductory or novice level expertise.
- Manufacturer is aware many operators restart Hole Digger's engine with auger in partially or completely dug hole on regular basis while in the field.
- Manufacturer also realizes procedure must be utilized when auger extension is used to extend digging depth. Manufacturer has no control over experience, skill and common sense levels of each operator of the Hole Digger.
- Manufacturer has no control over each job site or specific job application for the Hole Digger.

- Grass and other overgrowth conditions will hamper digging capability of any auger by becoming "clogged" around auger teeth and screw bit. Removal of such obstructions from hole location BEFORE digging will increase digging efficiency and overall productivity.

**CAUTION**

- DO NOT dig initial hole with smaller auger then use larger diameter auger to "ream" hole to desired size.
- This method will prevent auger screw bit of larger auger from providing sufficient directional stability during "reaming" process.

**WARNING**

- DO NOT use shovel and/or foreign object to remove loose soil from around hole area while operating Hole Digger.
- This can result in shovel and/or foreign object to become entrapped by rotating auger.

**10 OPERATING INSTRUCTIONS**



**IMPORTANT:** DO NOT operate Hole Digger until each operator completely comprehends contents of this manual, plus applicable safety and operational information supplied by engine manufacturer.

**INSTALLING AUGER**

- Refer to STOPPING HOLE DIGGER in OPERATING INSTRUCTIONS section of this manual. To install auger, place Hole Digger with spark plug facing up.

**DANGER**

- DO NOT connect auger to Hole Digger with engine running.
- A sudden change in engine speed will result in property damage and/or personal injury.

- Connect auger to Hole Digger with correct factory supplied auger pin.

**CAUTION**

- When installing auger and auger pin, always place Hole Digger with engine spark plug in upward position to minimize potential for oil and/or gasoline to enter combustion chamber and create a hydraulic lock up.
- Such occurrence can result in property damage and/or personal injury.

**CAUTION**

- DO NOT use any other connecting device except auger pin supplied with Hole Digger which is designed to withstand high stresses encountered while digging.
- Use of any other connecting device, including cap screws, bolts, pins, etc., can result in damage to Hole Digger driveshaft and/or auger drive hub.
- Improper connecting devices can cause property damage and/or personal injury.

**STARTING ENGINE WITH AUGER ATTACHED**

DO NOT attempt to dig with Hole Digger until operator is ready and is in full control of machine/accessories.

**DANGER**

- Hole Digger is designed for one operator. Use by more than one operator will lead to confusion and loss of control, resulting in property damage and/or personal injury.
- Start engine according to instructions outlined below to minimize possibility of unexpected auger rotation.
- Unexpected auger rotation can result in loss of machine control and possibility of property damage and/or personal injury.

**DANGER**

- To reduce potential for personal injury, stop Hole Digger between each hole.
- DO NOT choose to save time (time required to restart engine), money (if Hole Digger is being rented) or gain added convenience by electing to keep engine running between each hole.
- Actions can lead to loss of control, resulting in property damage and/or personal injury.

**WARNING**

- Hole Digger controls are designed for operator to choke and start engine with left hand while operating throttle control with right hand.
- With this intended operating position, the engine exhaust muffler faces away from operator, directing fumes and heat in opposite direction from operator.
- DO NOT operate Hole Digger with engine exhaust muffler/shield facing toward operator. This operating position will allow operator to come in contact with hot surface of engine muffler/shield and allow operator to inhale high levels of carbon monoxide resulting in property damage and/or personal injury.

**CAUTION**

- If Hole Digger and/or an individual component/accessory does not appear to function properly, STOP and DO NOT operate Hole Digger until corrective action has been completed.
- If you have any questions regarding proper operation of Hole Digger, contact Customer Service Department for assistance BEFORE using. There is no charge for this service.

- Place Hole Digger in vertical orientation on desired hole location so right hand operates throttle control.
- With left hand, open fuel tank breather vent (if so equipped) to its maximum set position. Failure to open breather vent prevents engine from receiving continuous supply of fuel.
- Gripping operator handle on left side with left hand, use right hand to turn engine ON/OFF ignition switch to ON position. FIGURE 2

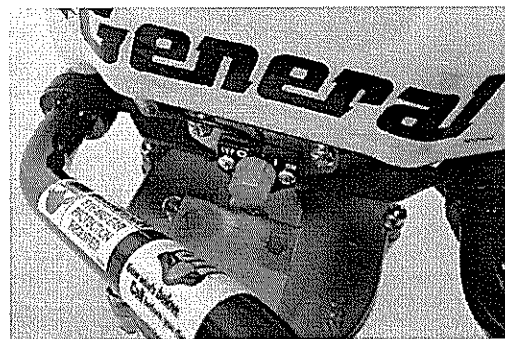

FIGURE 2

- With left hand, depress engine primer system bulb repeatedly until fuel can be seen in clear plastic fuel line and primer bulb. FIGURE 3

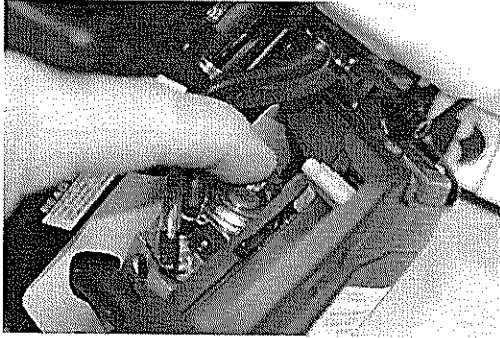

FIGURE 3

7. If engine is cold or the ambient temperature is low, using left hand, move choke control lever to the left/closed position (away from fuel tank). A warm (previously run) engine may not require choking. FIGURE 4



FIGURE 4



**CAUTION**

- Proper choke lever operation moves in a sideways motion as viewed by the operator.
- DO NOT move choke lever in a fore and aft direction, such action can result in damage to choke control mechanism.
- DO NOT apply excessive force when moving choke lever. Excessive force can damage carburetor.

8. Grip throttle control with right hand. It is not necessary to rotate the throttle control to start the engine.
9. Using left hand, pull engine starter recoil handle slowly, until resistance is felt (this is the compression point), then give a fast, short, steady pull. Allow starter rope to retract slowly. DO NOT pull rope out to its maximum, extended length. If engine does not start in three pulls, consult material supplied by engine manufacturer for specific information.

**NOTE:** Normally, engines not running for some time require three to five pulls to start. Recently run engines usually start on first or second pull. In cold weather, initial starting will require additional pulls due to extremely rich fuel/air mixture.

10. Allow engine to properly "warm up" and operate without requirement for engine choke. Check for proper centrifugal clutch operation, excessive transmission noise and/or vibration.
11. Rotate throttle control counterclockwise to increase engine speed/regulate digging process. Auger begins rotation when centrifugal clutch reaches initial engagement speed.

**PROPER OPERATOR STANCE (FIGURE 5 & 6)**

12. Grasp operator handle and throttle control firmly. Wrap fingers around handle and throttle control grip, keeping both cradled between thumbs and forefingers.
13. Keep wrists as perpendicular to operator handle and throttle control as feasible while digging. Proper wrist position can minimize and/or reduce stress and strain related damage potential to this body area, plus, operator control is enhanced and fatigue reduced. FIGURE 6

14. Keep left side of operator handle as close to waist/leg/arm areas as possible for maximum leverage/control and minimize effects of "kickback" if obstruction is encountered when digging.
15. Keep arms close to upper body, back as vertical as possible, and bend legs as needed to minimize physical stress.
16. Position left foot forward of right foot and a comfortable distance apart.

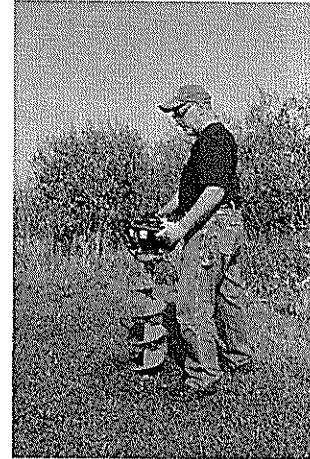

FIGURE 5



FIGURE 6

**NOTE:** Not using a proper operator stance (FIGURES 7, 8, 9):

- a) Reduces operator control and balance.
- b) Increases operator fatigue.
- c) Increases risk of property damage and/or personal injury.



FIGURE 7



FIGURE 8



FIGURE 9

**REMOVING STUCK AUGER FROM HOLE**

17. Usually due to excessive auger feed rate, an auger can "bind" and/or "bury" itself in the hole. This is also common when digging with smaller diameter 2 inch (50.8 mm) to 4 inch (101.6 mm) augers. When this occurs, DO NOT continue to overload and slip clutch assembly. Hole Digger is not capable of transmitting ample power to "free" auger.



**WARNING**

- Auger-LOK® System is designed for manual engagement and activation by the operator.
- DO NOT use chains and/or slings wrapped around Hole Digger and/or operator handle connected to external towing device such as a truck or loader to remove stuck auger.
- Improper action can result in property damage and/or personal injury.

NOTE: The Hole Digger uses a manually deployed Auger-LOK® to prevent gear rotation. Use the following procedure to remove a stuck auger from hole:

18. Before attempting to remove stuck auger from hole, STOP engine per STOPPING HOLE DIGGER in OPERATING INSTRUCTIONS section of this manual BEFORE moving to step 19 below.
19. Locate Auger-LOK® on top of transmission housing under spark plug/engine cooling fin area of engine. FIGURE 10



**CAUTION**



- Area can become hot to the touch.
- Wear gloves for added protection.

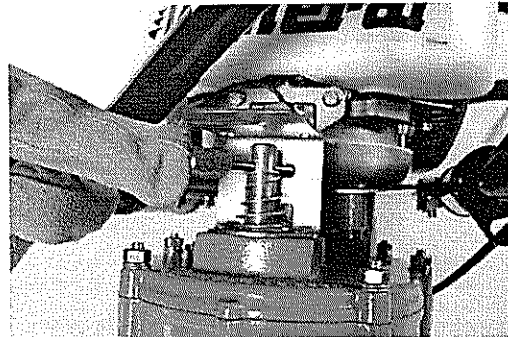

FIGURE 10

20. Push lock handle down slightly to disengage upper detent position. Turn lock handle counterclockwise (to right) until it stops against vertical slot of lock bracket. FIGURE 10
21. Push lock handle down until it stops against bottom slot of lock bracket and engages transmission gear. (Note, it may be necessary to rotate Hole Digger back and forth slightly to allow lock pin to fully engage gear.) Turn lock handle clockwise (to left) until it stops against right side of slot. Release allowing spring to push handle up into lower detent position. In this position, lock device is fully deployed. FIGURE 11

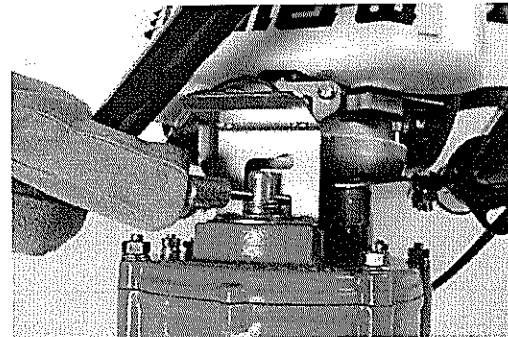

FIGURE 11

22. Grasp operator handle on both sides and rotate Hole Digger/auger counterclockwise (to left). DO NOT FORCE. Apply steady pressure until auger loosens in ground, continuing rotation until auger is freed from obstruction and Hole Digger/auger can be lifted from hole. An additional person may be necessary to assist in this process, one on each side of the widest portion of the operator handle.
23. Inspect Hole Digger/auger for damage. Remove any obstruction from auger and/or hole.
24. Reverse locking device process to disengage locking pin from gear. Check spring positions handle in upper detent position of locking bracket to prevent inadvertent lock deployment.



**CAUTION**

- Lock device spring should always be in direct contact with handle in any position.
- If this does not occur, lock device can become inadvertently deployed, resulting in property damage and/or personal injury.
- Replace worn or damaged spring with factory approved replacement part only.

25. Reconnect spark plug wire. Start engine and resume digging process per STARTING ENGINE WITH AUGER ATTACHED in OPERATING INSTRUCTIONS section of this manual.

**ADDING/REMOVING NONFLIGHTED AUGER EXTENSION**

For holes deeper than standard augers provide, a non-flighted auger extension increases digging depth 15 inches (381 mm). Additional operator experience, over introductory/novice skill levels, is required when using. Follow this accepted procedure to add non-flighted extension:

26. Dig to approximate full depth of auger following operating instructions. Remove as much loose soil from hole as possible per STEP 6 of HOLE DIGGING TECHNIQUES in APPLICATION THEORY & TECHNIQUES section of this manual.
27. STOP Hole Digger per STOPPING HOLE DIGGER in OPERATING INSTRUCTIONS section of this manual.
28. Remove Hole Digger/auger from hole. Disconnect auger from Hole Digger. Place auger in hole. Attach auger extension to auger and secure with auger pin. The Hole Digger can now be connected to auger extension using auger pin.

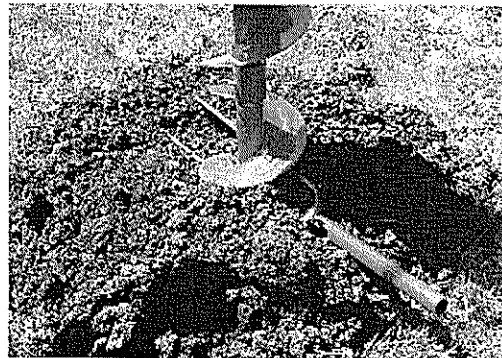

FIGURE 13



**CAUTION**

- Utilization of non-flighted auger extensions requires additional operator experience, skill and common sense over introductory or novice level of expertise.
- Manufacturer has no control over experience, skill and common sense levels of each operator of Hole Digger.
- Each operator must decide if his experience, skill and common sense level is sufficient to allow him to proceed with use of non-flighted auger extensions for any given and/or specific job application.



**WARNING**



- Never utilize more than one non-flighted auger extension to increase overall digging depth.
- Non-flighted auger extensions are not equipped with auger flighting to elevate loose borings from hole.
- Multiple use of non-flighted auger extensions will allow auger to "bury" itself in hole. Such use can lead to loss of operator control and/or personal injury.

33. Disconnect Hole Digger from auger extension. Disconnect auger extension from auger.
34. Reconnect Hole Digger to remaining auger and remove power unit/auger from hole. Reconnect spark plug wire.
35. Per STARTING ENGINE WITH AUGER ATTACHED in OPERATING INSTRUCTIONS section of this manual dig next hole based on job application. If project is complete, store Hole Digger per STORAGE section of this manual.

**STOPPING HOLE DIGGER**

36. Stop Hole Digger by releasing throttle control grip. Engine should return to the idle speed position. FIGURE 14

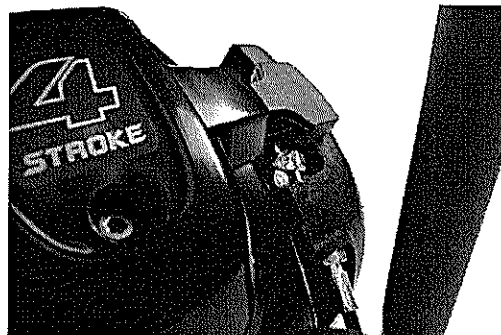

FIGURE 14

NOTE: If engine power does not return to the idle speed position, check throttle control grip, throttle cable, and engine throttle control arm for binding and/or improper adjustment.



**WARNING**



- Stop Hole Digger between each hole.
- Never leave Hole Digger running and unattended.
- Not doing so can result in property damage and/or personal injury.

29. Per STARTING ENGINE WITH AUGER ATTACHED in OPERATING INSTRUCTIONS section of this manual, dig to desired depth or to full depth of auger extension. To remove auger extension, follow this accepted procedure:
30. STOP Hole Digger per STOPPING HOLE DIGGER in OPERATING INSTRUCTIONS section of this manual.
31. Remove as much loose soil from hole as possible per STEP 6 of HOLE DIGGING TECHNIQUES in APPLICATION THEORY & TECHNIQUES section of this manual.
32. Lift auger extension/auger/Hole Digger up far enough out of hole so bottom end of auger extension is clear. FIGURE 12. Block remaining auger with auger fork to prevent falling back into hole. An additional person will usually be required. FIGURE 13

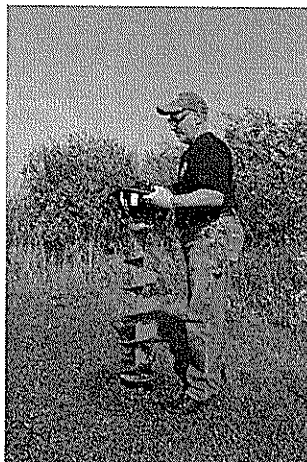

FIGURE 12

37. Turn engine ON/OFF ignition switch to OFF position.
38. Disconnect spark plug wire to prevent accidental engine starting.
39. When engine is not in operation or is to be stored, close fuel tank breather vent (if so equipped). Turn fuel tank ON/OFF valve (if so equipped) to OFF position to minimize fuel flooding carburetor and/or entering engine crankcase and/or impacting upon environment.

## 11 MAINTENANCE INSTRUCTIONS



For routine maintenance, the following information should be followed once per week or 40 hours of use at minimum for maximum performance and return on investment unless otherwise indicated. Information is for reference only and is not intended to be all inclusive.

1. Use factory approved replacement parts/accessories only for maintenance and repair.



### WARNING

- Operating Hole Digger utilizing components not meeting minimum operational standards can result in property damage and/or personal injury.

2. All maintenance/repairs not described in this operator manual must be done by a dedicated service center following a specific service/repair manual.
3. STOP Hole Digger BEFORE performing maintenance and service per STOPPING HOLE DIGGER in OPERATING INSTRUCTIONS section of this manual.



### WARNING

- DO NOT perform service and/or repair related functions with Hole Digger mounted to 999 Series Display Stands. Stands are not designed and/or intended for hole digging and service functions.
- Such use can result in property damage and/or personal injury.

4. Inspect for loose or broken parts. Inspect all fasteners, individual parts, operator controls and safety devices for proper function. Tighten fasteners as necessary. Replace any worn or damaged part or assembly.
5. Remove all loose accumulations, dirt, grease to prevent safety hazards, poor performance and reduced service life using safety type solvent.



### DANGER



- Use safety type solvent.
- DO NOT use thinner, benzene, or other volatile solvents that will attack rubber/plastic components when cleaning Hole Digger.
- Provide adequate ventilation.
- DO NOT smoke while using cleaning solvents.
- DO NOT use solvents with engine running or if it is hot.
- Allow ample time for engine to cool BEFORE using solvents.
- An ignition source in close proximity to hot engine can be the source of an explosion, resulting in property damage and/or personal injury.

6. Inspect engine throttle control and throttle cable assemblies are not damaged, bent, abraded or parts missing, are in correct operating position and allow for complete freedom of movement. DO NOT operate Hole Digger with damaged engine throttle control arm and/or throttle cable assembly.
7. Inspect throttle control grip is free of moisture, pitch, oil or grease and is not cracked, damaged or worn. DO NOT operate Hole Digger until such grip is repaired and/or replaced to prevent aggravated effects of "kickback and/or loss of operator control when digging.
8. Inspect operator handle and attach areas for signs of cracking, fatigue, deformation or damage. If cracking, fatigue, deformation or damage is present, replace. Keep handle clean and free of dirt, moisture, grease, oil and other, foreign material accumulations.

**IMPORTANT:** Keep external condition of operator handle and throttle control free of accumulation of moisture, dirt, pitch and other foreign substance that can provide a conductive pathway for energy to be transmitted. Throttle control should be maintained in clean, dry condition and free of all foreign materials.

9. Inspect centrifugal clutch assembly properly disengages at specified engine speed or slips during overload conditions.
10. Inspect engine muffler for wear or damage and replace as necessary to minimize fire hazard and hearing loss risk. If muffler is equipped with a spark arresting device, check for proper working condition. If not, replace with approved replacement from engine manufacturer.

**IMPORTANT:** It is owner(s) and/or operator(s) responsibility to provide and maintain a USDA approved, spark arresting muffler in an operating area specified by law. Check appropriate governing agencies for more specific information. Hole Digger must not be operated if muffler is faulty or has been removed.

11. Inspect all safety and operation decals. If any decal becomes damaged and/or unreadable, replace.
12. Hole Digger may utilize self-locking type hexagon nuts to minimize effects of vibration. If worn or damaged, replace.
13. Inspect auger for bent or damaged axle that will cause auger to "wobble" during use and can cause loss of machine control. Maximum allowable auger wobble is 0.25 inch (6.4 mm) total indicator runout (TIR). Augers with TIR in excess of this value must be removed from service and scrapped.
14. Inspect auger blade and screw bit for excessive wear, cracking, sharpness and missing parts. Replace as required to prevent undo wear to boring head and inverted cone configuration to auger fighting. The end result is substandard productivity and usually requires complete auger replacement. FIGURE 15. Auger service life can be greatly extended with constant auger wear part maintenance.

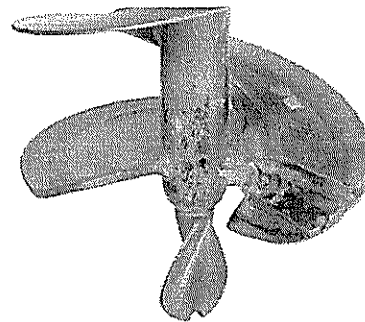

FIGURE 15



### WARNING

- DO NOT use auger with auger blade and screw bit worn past their specific service limits.
- Excessive wear to auger blade and screw bit will allow auger fighting to wear in a tapered or inverted cone configuration.
- A worn boring head may only be capable of digging a hole 60 to 75 percent of auger nominal diameter.
- Configuration will allow auger to "bind" in hole and substantially reduce operator control and productivity.



### DANGER

- DO NOT operate auger which has bent or damaged axle with total indicator runout exceeding maximum allowable limit.
- Excessive auger wobble can reduce operator control, resulting in property damage and/or personal injury.

15. Consult material supplied by engine manufacturer for specific information relative to proper operation, lubrication and storage requirements.

**CHANGING HOLE DIGGER TRANSMISSION GREASE**

**Tools Required:**

- 1 each, 7/16 inch (12 mm) wrench
- 1 each, #2 Phillips head screwdriver
- 1 each, torque wrench, 120 inch pounds (13.5 N.m.) capacity with 7/16 inch (12 mm) socket
- 1 each, plastic hammer

**Parts Required:**

- 1 each, PN 240-0100PAK2 transmission gasket
- 1 each, PN 210-0720 grease packet or 8 ounces (224 g) of high temperature transmission or marine-grade, wheel bearing grease classified for extreme pressure (EP) applications. Fisk Brothers (Lubriplate brand) GR132 is an approved lubricant.

**NOTE:** Changing transmission lubricant will require a level working platform of sufficient size and appropriate height. As an alternative, the transmission driveshaft can be securely mounted in suitable bench vise.

1. Change transmission grease every 50 hours of operation, or more often as necessary, if Hole Digger is operated in extremely dusty or dirty conditions.
2. STOP Hole Digger per STOPPING HOLE DIGGER in OPERATING INSTRUCTIONS section of this manual.
3. Drain fuel from fuel tank into a UL, CSA or UN marked, European ADR regulation approved fuel container. Wipe any excess spilled fuel and dispose of excess fuel and/or rags per international and local regulations.

**⚠ DANGER** 

- DO NOT smoke near fuel tank.
- DO NOT fill fuel tank with engine running or if it is hot.
- Allow ample time between each refueling for engine to cool.
- An ignition source in close proximity to fuel tank can be the source of an explosion, resulting in property damage and/or personal injury.
- Consult material supplied by engine manufacturer for information relative to proper fueling procedures.

4. Remove transmission assembly bolts. Use plastic hammer to split/separate transmission cover and case. DO NOT damage alignment dowel pins.

**NOTE:** If journals of secondary pinion gear are difficult to remove from ball bearings, transmission cover and case will separate with greater difficulty. It may be necessary to provide a supplemental force to the pinion journals to assist the removal process. If difficult to remove, complete STEP 5 thru 6. If able to remove journals easily and separate cover and case, proceed to STEP 7.

5. Using Phillips screwdriver, remove screw, lock washer and flat washer from outside of transmission case and set aside. FIGURE 16
6. Insert a 1/4-20 UNC cap screw with a minimum 1 inch (25.4 mm) into location where screw was removed. Using wrench, turn capscrew in clockwise direction to apply thrust against pinion bearing journal until it clears pinion gear support bearing. Repeat process with transmission cover if necessary. FIGURE 16

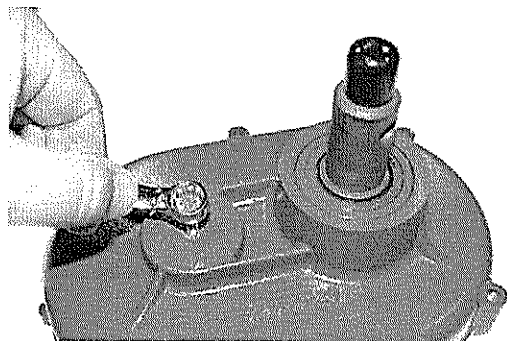



FIGURE 16

7. Remove gasket plus, primary gear and pinion assembly.
8. Clean interior surfaces of transmission cover and case plus, pressure relief valve with safety type solvent.
9. Clean each gear with safety type solvent. Inspect teeth for excess wear, cracks or fatigue. Replace parts as necessary.

**⚠ DANGER** 

- Use safety type solvent.
- DO NOT use thinner, benzene, or other volatile solvents that will attack rubber/plastic components when cleaning Hole Digger.
- Provide adequate ventilation.
- DO NOT smoke while using cleaning solvents.
- DO NOT use solvents with engine running or if it is hot.
- Allow ample time for engine to cool BEFORE using solvents.
- An ignition source in close proximity to hot engine can be the source of an explosion, resulting in property damage and/or personal injury.

10. Fill transmission cover and case with 8 ounces (224 g) of high temperature transmission grease containing an extreme pressure additive. If Fisk Brothers GR-132 lubricant is not available, marine-grade, wheel bearing grease classified for extreme pressure (EP) applications can be used in its place. Refer to FIGURE 17

**IMPORTANT:** DO NOT use standard lithium-based greases intended for common lubrication purposes. Such grease does not contain an extreme pressure additive for use with gears or for operating at higher temperatures encountered during hole digging process.

11. Reinstall primary gear and pinion assembly. Distribute grease equally around all gear teeth. Install new transmission gasket. FIGURE 17

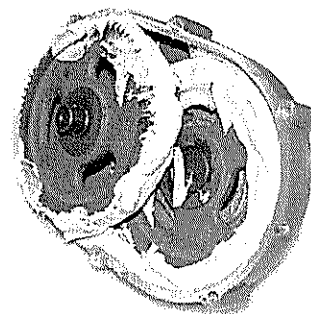

FIGURE 17

12. Reinstall transmission cover to case, being careful to align transmission dowel pins during process.
13. Reinstall transmission assembly bolts with hexagon nuts placed on transmission cover side. Torque all bolts to 96 inch pounds (12 N.m.) in an "X" sequence.
14. Rotate driveshaft and check for excessive noise and/or binding. If excessive noise and/binding is evident, disassemble transmission and investigate for probable causes. Reassemble and retorque to specified amount. Recheck for excessive noise and/or binding.



**MAGURA® THROTTLE CONTROL MAINTENANCE PROGRAM**

For every 8 hours of actual operation and whenever throttle cable is replaced, the following maintenance program is to be followed:

1. Remove plastic cover to properly inspect internal components. If damaged or worn, replace. FIGURE 18

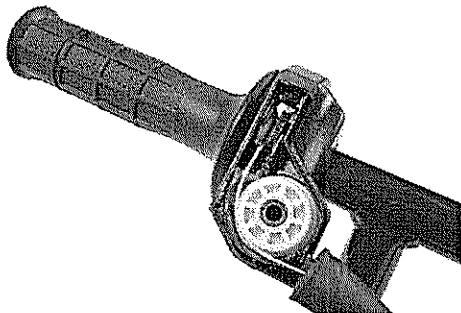

FIGURE 18

2. Inspect idler pulley. Normal use will produce a wear pattern into idler pulley by throttle cable. Maximum allowable groove wear depth created by cable is 0.045 inch (1.1 mm). Wear depth in excess of this limit requires idler pulley replacement.
3. Inspect throttle cable for excessive wear and fraying of area in direct contact with idler pulley. Abnormal wear or fraying requires replacement of throttle cable.
4. Inspect barrel end of throttle cable for proper retention. Properly retained barrel end will have no relative movement between it and inner cable. Any relative movement requires throttle cable replacement. FIGURE 19

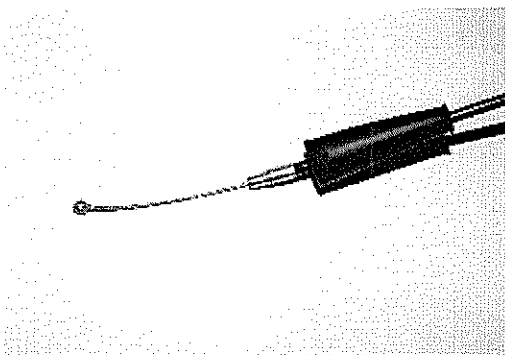

FIGURE 19

5. Inspect receptacle area of throttle control which retains barrel end of throttle cable. Properly fitted barrel fitting should have complete freedom of movement with no binding restrictions or excessive play due to wear. Barrel fitting which is binding within receptacle requires throttle cable replacement. Excessive receptacle wear requires specific component assembly replacement. FIGURE 20

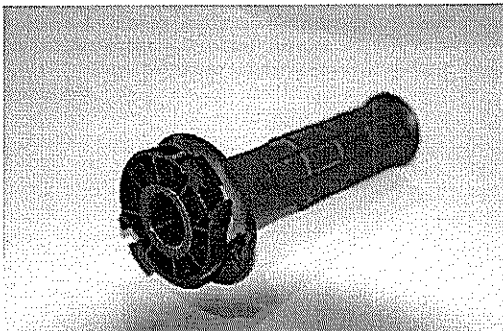

FIGURE 20



**CAUTION**

- DO NOT operate Hole Digger without rubber boot in proper location or in poor condition.
- Without boot assembly, foreign material can accumulate within throttle control assembly.
- Such an occurrence can restrict movement of internal components, reducing operator control of Hole Digger and result in property damage and/or personal injury.

6. Apply appropriate preservative to rubber boot assembly to protect internal components from foreign material accumulations.
7. If regular throttle control inspection determines carburetor return spring does not properly return to engine cut-off position, remove throttle control grip tube from throttle control handle. Inspect tube and operator handle surface area for accumulation of foreign material, including dirt, moisture, etc. Remove any accumulation, clean as necessary. DO NOT apply external lubrication to this area during reassembly process.
8. Inspect throttle control grip proper attachment to throttle control assembly. Replace grip which fits loose or has become worn/damaged.

**REPLACING WORN AUGER SCREW BIT**

Application: All 2350 Series augers 4 inch (101.6 mm) through 8 inch (203.2 mm) diameter augers.



**DANGER**

- Wear safety eyewear and other safety apparel appropriate for the job application and/or job site environment.
- Screw bit replacement process can create flying steel chips and/or other debris.
- Caution all onlookers regarding the possibility of and/or to remain clear of flying debris.
- Improper safety procedures can result in property damage and/or personal injury.

**Tools Required:**

- 1 each, safety glasses
- 1 each, hammer (if required)
- 1 each, 1/4 inch diameter straight-type punch (if required)
- 2 each, 1/2 inch (12.7 mm) wrenches

**Parts Required:**

- 1 each, PN P302 Screw Bit for 3 inch (76.2 mm) diameter auger.
- 1 each, PN P801 Screw Bit for 2 inch (50.8 mm) and 4 inch (101.6 mm) to 8 inch (203.2 mm) diameter augers.
- 1 each, PN 20051000 Roll Pin for 2 inch (50.8 mm) and 3 inch (76.2 mm) diameter augers if required.
- 1 each, PN 15051300 Bolt for 4 inch (101.6 mm) to 8 inch (203.2 mm) diameter augers, if required.
- 1 each, PN 52050000 Nut for 4 inch (101.6 mm) to 8 inch (203.2 mm) diameter augers, if required.

**NOTE:** Screw bit for 2 and 3 inch diameter augers functions as boring head. No other blade is used.

**NOTE:** Replacement of auger screw bit will require a level working platform of appropriate size and height.

1. Inspect auger for excess wear and/or damage. A replacement screw bit will not allow auger with excess wear and/or damage to properly dig.
2. For 2 and 3 inch diameter augers, use hammer and straight-type punch to remove roll pin and screw bit.
3. For 4-inch diameter auger and above, use 1/2 inch (12.7 mm) wrenches to remove bolt and screw bit.
4. Insert replacement screw bit, align holes and reinstall applicable roll pin or bolt and nut with appropriate tools.
5. Return auger back to service.





1. Drain fuel from fuel tank into a UL, CSA or UN marked, European ADR regulation approved fuel container and oil from engine crankcase. If re-use is not possible, disposal must be carried out according to international and local environmental standards.

**⚠ DANGER**

- DO NOT smoke near fuel tank.
- DO NOT fill fuel tank with engine running or if it is hot.
- Allow ample time between each refueling for engine to cool.
- An ignition source in close proximity to fuel tank can be the source of an explosion, resulting in property damage and/or personal injury.
- Consult material supplied by engine manufacturer for information relative to proper fueling procedures.

2. Using 7/16 inch (12 mm) wrench, remove four K-lock type nuts that retain engine to transmission. Remove engine from transmission and operator handle from engine leaving throttle cable connected to engine. Store operator handle in a position that does not damage throttle cable.
3. Position engine with rotor and shoe assembly facing up. Properly secure to prevent movement.
4. Using impact wrench and 17 mm socket, remove two capscrews retaining rotor and shoe assembly. NOTE: capscrew threads are righthanded. Remove rotor and shoe assembly from engine flywheel. FIGURE 21

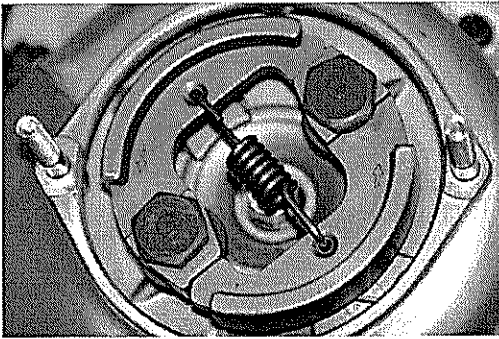

FIGURE 21

5. Clean engine flywheel and clutch drum areas with safety type solvent.

**⚠ DANGER**

- Use safety type solvent.
- DO NOT use thinner, benzene, or other volatile solvents that will attack rubber/plastic components when cleaning Hole Digger.
- Provide adequate ventilation.
- DO NOT smoke while using cleaning solvents.
- DO NOT use solvents with engine running or if it is hot.
- Allow ample time for engine to cool BEFORE using solvents.
- An ignition source in close proximity to hot engine can be the source of an explosion, resulting in property damage and/or personal injury.

6. Inspect engine flywheel, crankcase castings, mounting studs and clutch drum for cracks and other signs of visible damage. Any damaged component will require immediate replacement.
7. If clutch drum shows signs of severe wear and/or damage and requires replacement, refer to CENTRIFUGAL CLUTCH DRUM/PINION SHAFT REMOVAL AND INSTALLATION in SERVICE/REPAIR INSTRUCTIONS section of this manual. Severe wear is defined as:
  - a) Deep grooves cut into walls of drum measuring greater than 3.140 inch (79.76 mm) diameter.

- b) Deep, dark blue color that might indicate sustained operation at high temperatures while slipping. Extended and sustained operation can potentially weaken structural integrity of the brazed connection between drum and pinion shaft.

8. Clean and inspect hardware that retains rotor and shoe assembly to the engine flywheel. Replace any component showing cracks and other signs of visible damage that are present.
9. Apply Lockite 609 or equivalent to the shoulder bolt threads.
10. Locate replacement clutch rotor and shoe assembly plus, thrust washers on engine flywheel with direction arrow pointing in counterclockwise direction. This orientation properly maximizes the torque transmitting capabilities of the clutch. Refer to FIGURE 21

**⚠ CAUTION**

- Improper clutch and rotor shoe assembly orientation will result in increased slippage and reduced digging capacity with increased clutch wear.

11. Reinstall retaining shoulder bolts to 5.4-7.2 foot pounds (7.5-10 N.m.). When properly installed and torqued, shoulder bolts should not thrust directly against washers, but apply a direct force against the clutch shoes. If force is applied against the washers, it will restrict proper movement of the clutch shoes.

**⚠ CAUTION**

- Improper shoulder bolt clearance will limit proper movement of clutch shoes and overall operation.
- Such an occurrence can result in property damage and/or personal injury.

12. Reinstall operator handle to engine and engine to transmission with correct orientation to the operator handle. Throttle control of operator handle goes on same side of engine with ON/OFF ignition switch and same side of transmission cover that pressure relief valve is located.

**⚠ WARNING**

- Improper engine mounting orientation to transmission can reduce machine control during hole digging process.
- Such an occurrence can result in property damage and/or personal injury.

13. Using 7/16 inch (12 mm) wrench, reinstall and tighten the four K-lock nuts. Tighten nuts to an approximate 90 inch pound (10 N.m.) value. This will place the nut flush with end of engine mounting stud.

NOTE: There is not adequate space to allow use of a conventional torque wrench.

14. Rotate driveshaft and check for excessive noise and/or binding. If excessive noise and/or binding is evident, disassemble engine from transmission and investigate for probable causes. Reassemble and retorque to the specified values. Recheck again for excessive noise and/or binding.
15. Refill engine fuel tank and crankcase with appropriate fluids as required.

#### CENTRIFUGAL CLUTCH DRUM/PINIONSHAFT ASSEMBLY REMOVAL & INSTALLATION

##### Tools Required:

- 2 each, 7/16 inch (12 mm) wrenches
- 1 each, plastic hammer
- 1 each, #2 Phillips head screwdriver
- 1 each, snap ring pliers
- 1 each, torque wrench, 120 inch pounds (13.5 N.m.) capacity

##### Parts Required:

- 1 each, PN 240-0100PAK2 transmission gasket
- 1 each, PN 242-0160 drum and pinion shaft assembly
- 1 each, PN 5100-088 snap ring
- 1 each, container of thread anti-seize

NOTE: Centrifugal clutch drum/pinion shaft assembly removal and installation will require a level working platform of sufficient size and appropriate height. As an alternative, the transmission output driveshaft can be securely mounted in suitable bench vise.

1. Drain fuel from fuel tank into a UL, CSA or UN marked, European ADR regulation approved fuel container and oil from engine crankcase. If re-use is not possible, disposal must be carried out according to international and local environmental standards.

**⚠ DANGER**

- DO NOT smoke near fuel tank.
- DO NOT fill fuel tank with engine running or if it is hot.
- Allow ample time between each refueling for engine to cool.
- An ignition source in close proximity to fuel tank can be the source of an explosion, resulting in property damage and/or personal injury.
- Consult material supplied by engine manufacturer for information relative to proper fueling procedures.

2. Using 7/16 inch (12 mm) wrench, remove four K-lock type nuts that retain engine to transmission. Remove engine from transmission and operator handle from engine leaving throttle cable connected to engine. Store operator handle in a position that does not damage throttle cable.
3. Remove transmission assembly bolts. Use plastic hammer to split/separate transmission cover and case. DO NOT damage alignment dowel pins.

NOTE: If bearing journals of secondary pinion gear are difficult to remove from ball bearings, transmission cover and case will separate with greater difficulty. It may be necessary to provide a supplemental force to the pinion journals to assist the removal process. If difficult to remove, complete STEP 4 thru 5. If able to remove journals easily and separate cover and case, proceed to STEP 6.

4. Using Phillips screwdriver, remove screw, lock washer and flat washer from outside of transmission cover and set aside. FIGURE 22
5. Insert a 1/4-20 UNC cap screw with a minimum 1 inch (25.4 mm) into location where screw was removed. Using wrench, turn capscrew in clockwise direction to apply thrust against pinion bearing journal until it clears pinion gear support bearing. FIGURE 22

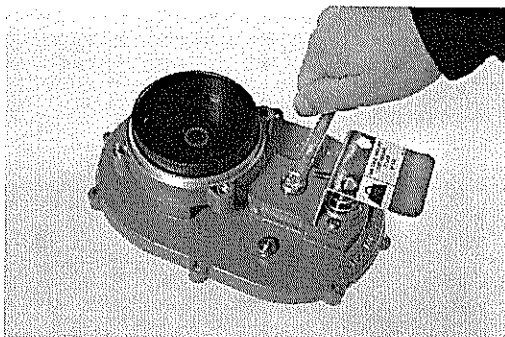

FIGURE 22

6. Using snap ring pliers, remove snap ring retaining clutch drum/shaft assembly to transmission cover. FIGURE 23

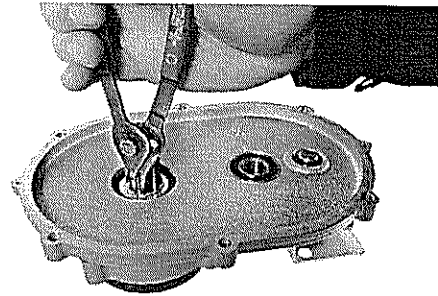

FIGURE 23

7. Inspect support bearings for excessive wear. Replace as necessary.
8. Install replacement drum/shaft assembly in transmission cover. Determine drum fits tight against the bearings.
9. Reinstall snap ring.
10. If it is determined transmission grease should be replaced, refer to CHANGING HOLE DIGGER TRANSMISSION LUBRICANT in MAINTENANCE INSTRUCTIONS section of this manual.
11. Remove old gasket and install new one.
12. Reinstall transmission cover to case, being careful to align transmission dowel pins during process.
13. Reinstall transmission assembly bolts with hexagon nuts placed on transmission cover side. Torque all bolts to 96 inch pounds (12 N.m.) in an "X" sequence.
14. Rotate driveshaft and check for excessive noise and/or binding. If excessive noise and/or binding is evident, disassemble transmission and investigate for probable causes. Reassemble and retorque to specified amount. Recheck for excessive noise and/or binding.
15. Reinstall operator handle to engine and engine to transmission with correct orientation to the operator handle. Throttle control of operator handle locates on same side of engine with ON/OFF ignition switch and same side of transmission cover that pressure relief valve is located.



**WARNING**

- Improper engine mounting orientation to transmission can reduce machine control during hole digging process.
- Such an occurrence can result in property damage and/or personal injury.

16. Using 7/16 inch (12 mm) wrench, reinstall and tighten the four K-lock nuts. Tighten nuts to an approximate 90 inch pound (10 N.m.) value.

NOTE: There is not adequate space to allow use of a conventional torque wrench.

17. Rotate driveshaft and check for excessive noise and/or binding. If excessive noise and/or binding is evident, disassemble engine from transmission and investigate for probable causes. Reassemble and retorque to the specified values. Recheck again for excessive noise and/or binding.
18. Refill engine fuel tank and crankcase with appropriate fluids as required.

**ENGINE SERVICE**

Consult applicable material supplied by engine manufacturer for specific service and maintenance information regarding:

1. muffler
2. spark plug
3. air filter
4. carburetor adjustment
5. maintenance schedule
6. engine oil change
7. troubleshooting
8. short and long term storage

Keep this information stored with Operator Manual for Hole Digger so it will always be available for use when engine requires service or maintenance.

Under Title 13 If the California Code of Regulations, the California Air Resource Board (CARB) has identified several important engine service related subjects. The material supplied by specific engine manufacturer will include the following:

1. statement of compliance
2. engine oil recommendations
3. engine fuel recommendations
4. maintenance information
5. other information as required by (CARB)
6. emission component warranty statement

If you have any question regarding emission components, warranty rights and responsibilities for a specific engine used on Hole Digger, contact Customer Service Department for specific information. There is no charge for this service.

**13 TROUBLESHOOTING**

**NOTE:** If troubleshooting information does not correct situation, all maintenance/repairs not described in this operator manual must be done by a dedicated service center following a specific service/repair manual.

**ENGINE WILL NOT START**

Possible Cause	Correction
Ignition cut-off switch (if equipped) improperly adjusted.	Adjust throttle cable.
Incorrect carburetor adjustment.	See engine manufacturer supplied information.
Ignition wire to spark plug loose or disconnected.	Reconnect.
Fuel supply exhausted.	Refill fuel tank.

**ENGINE LOSES POWER**

Possible Cause	Correction
Incorrect carburetor adjustment.	See engine manufacturer supplied information.
Water in fuel supply.	Drain and replace fuel.
Plugged engine exhaust ports.	See engine manufacturer supplied information.
Dirty spark plug.	See engine manufacturer supplied information.
Incorrect throttle control/cable adjustment.	See MAINTENANCE INSTRUCTIONS this manual.
Gasoline tank breather vent closed (if so equipped).	Open vent.
Dirty air filter.	See engine manufacturer supplied information.

**ENGINE OVERHEATS**

Possible Cause	Correction
Incorrect carburetor adjustment.	See engine manufacturer supplied information.
Cooling fins clogged with debris.	Remove engine blower housing and clean cooling fins.

**HOLE DIGGER LACKS POWER**

Possible Cause	Correction
Incorrect transmission lubricant.	See CHANGING HOLE DIGGER TRANSMISSION LUBRICANT in MAINTENANCE INSTRUCTIONS this manual.
Centrifugal clutch assembly worn.	Replace.
Incorrect throttle control/cable adjustment.	See MAINTENANCE INSTRUCTIONS this manual.

**AUGER ROTATES AT IDLE SPEED**

Possible Cause	Correction
Incorrect throttle control/cable adjustment does not permit proper engine idle speed.	See MAINTENANCE INSTRUCTIONS this manual.
Centrifugal clutch worn.	Replace.
Incorrect engine idle speed.	See MAINTENANCE INSTRUCTIONS this manual.

**14 STORAGE**

**TEMPORARY STORAGE (On Job Site)**

Hole Digger can be temporarily stored on job site by one of three acceptable methods. Method chosen by operator is based on personal preference and/or job site conditions.

1. In all three storage methods, STOP Hole Digger per STOPPING HOLE DIGGER in OPERATING INSTRUCTIONS section of this manual.

- a. Dig shallow hole and leave Hole Digger connected to auger. FIGURE 24

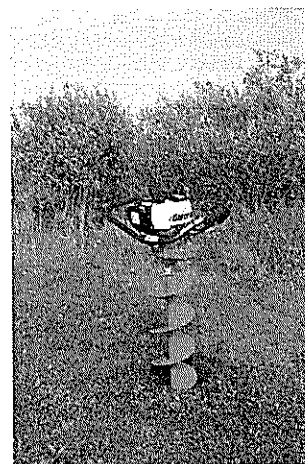

FIGURE 24

- b. Disconnect Hole Digger from auger and/or auger extension and store in level configuration. FIGURE 25

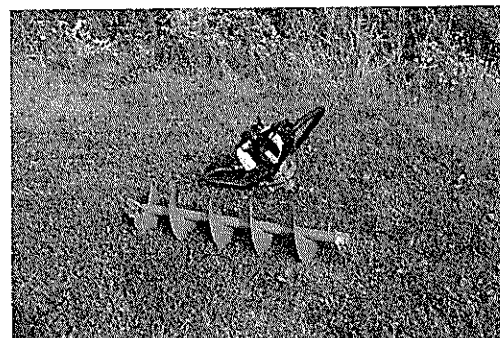

FIGURE 25

- c. Store Hole Digger connected only to lead auger with engine spark plug facing upward to minimize potential for crankcase oil entering combustion chamber and causing hydraulic lock up. FIGURE 26

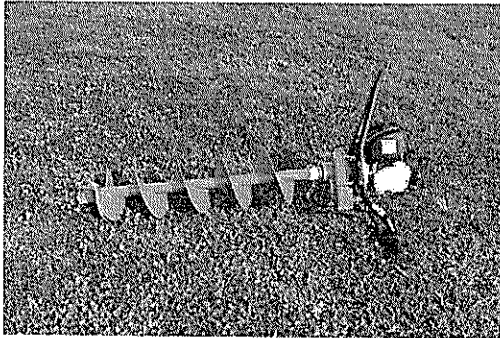

FIGURE 26

2. Protect operator handle from external sources of damage. DO NOT allow handle to contact augers, shovels, or other sharp/abrasive objects during transit whether stacked or thrown against handles. DO NOT drag Hole Digger with handle or throttle grip contacting ground. Damage can result.

**WARNING**

- DO NOT drop or impact Hole Digger against ground.
- Action can damage twist grip throttle control, engine and result in property damage and/or personal injury.

**DANGER**

- DO NOT store Hole Digger with engine operating.
- Improper storage methods can result in property damage and/or personal injury.

**LONG TERM STORAGE**

Procedure for Hole Digger long term storage will protect against effects of corrosion and damage. If Hole Digger is not to be operated for a period of 30 days or more, proceed to store as follows:

1. STOP Hole Digger per STOPPING HOLE DIGGER in OPERATING INSTRUCTIONS section of this manual.

**DANGER**

- Improper storage methods can result in property damage and/or personal injury.

2. Disconnect auger from Hole Digger.
3. Follow procedure as outlined in material supplied by engine manufacturer detailing long term storage of engine.
4. Clean all accumulated dirt and grease from Hole Digger utilizing safety type solvent. Provide adequate ventilation and observe all applicable safety precautions for solvent.

**DANGER**

- Use safety type solvent.
- DO NOT use thinner, benzene, or other volatile solvents that will attack rubber/plastic components when cleaning Hole Digger.
- Provide adequate ventilation.
- DO NOT smoke while using cleaning solvents.
- DO NOT use solvents with engine running or if it is hot.
- Allow ample time for engine to cool BEFORE using solvents.
- An ignition source in close proximity to hot engine can be the source of an explosion, resulting in property damage and/or personal injury.

5. Inspect all visible parts for wear, breakage or damage. Replace any part required to make necessary repair with factory approved parts only.

6. Apply light coat of protective grease to transmission driveshaft to prevent formation of rust.
7. Store Hole Digger with operator handle level with ground to minimize potential for crankcase oil entering combustion chamber and creating hydraulic lock up.
8. DO NOT allow handle to come in contact with augers, shovels, or other sharp and abrasive objects during storage to prevent damage.
9. Store Hole Digger inside. If Hole Digger must be stored outside, protect it and each auger with a suitable covering.

**15 END OF LIFECYCLE**



If the machine comes to the end of its lifecycle, destruction of the machine must be conducted according to international and local environmental regulations.

**16 DECLARATION OF CONFORMITY**

We, General Equipment Company, 620 Alexander Drive SW, P.O. Box 334, Owatonna, MN 55060, USA declare under our sole responsibility that the portable hole digger product: 242H

To which this declaration relates is in conformity with the following standards or standardization documents:

- EN-ISO 12100:2010

According to the provisions of the European directive:

- 2006/42/EC

Manufactured at: Owatonna, Minnesota 55060, USA  
Beginning with serial number: 174809

Signature: Dennis Von Ruden  
Position: President  
Date: September 14, 2020

THIS PAGE INTENTIONALLY  
LEFT BLANK

*Replacement Parts Diagram  
242H Hole Digger  
Equipped With Honda GX35 Engine*

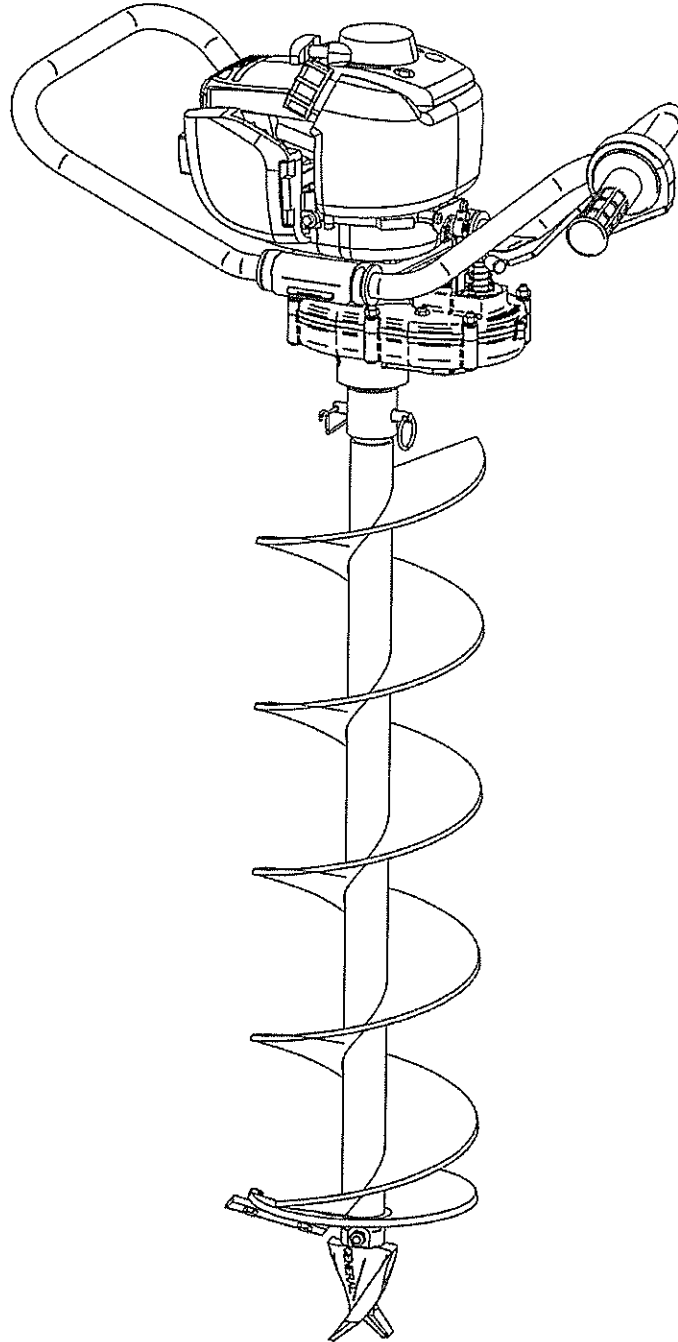

# Replacement Parts Diagram Transmission Cover Assembly 242H Hole Digger [Beginning with Serial Number 174809]

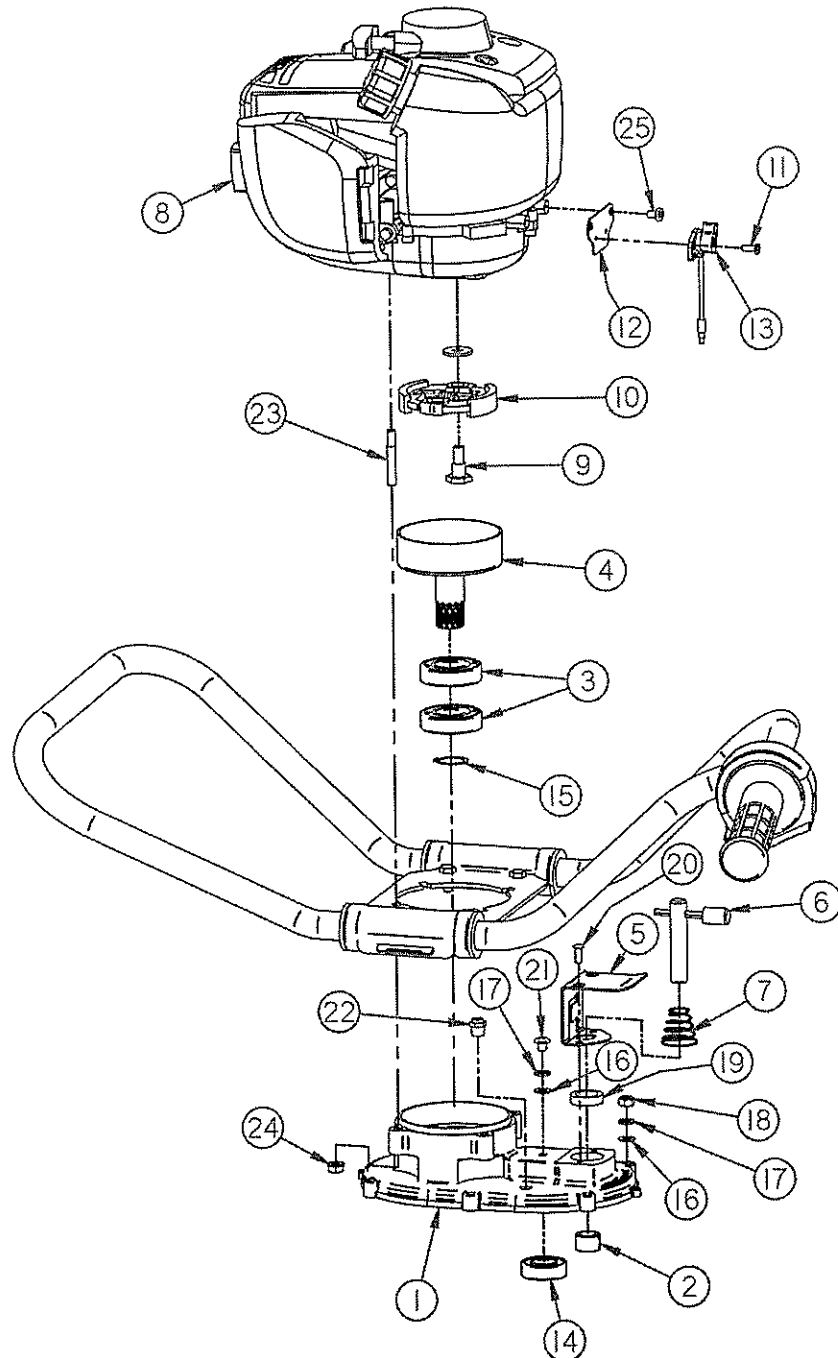



*Replacement Parts Diagram  
 Transmission Cover Assembly  
 242H Hole Digger  
 [Beginning with Serial Number 174809]*

Reference Number	Part Number	Description	Quantity
1	242-0130A	Assembly, Cover, Transmission, (Includes Ref. 2, 3 & 14)	1
2	235-0140	Bushing, Spring-Type	1
3	FCS16-0331	Bearing, Support	2
4	242-0160	Drum, Clutch	1
5	235-0230	Plate, Pin, Lock	1
6	235-0220	Assembly, Pin, Lock	1
7	235-0110	Spring, Pin, Lock	1
8	GX35NTT3-BLK	Engine, Honda, GX35	1
9	240-0180	Screw, Cap, Retaining, Clutch	2
10	240-0170	Assembly, Rotor/Shoe, Clutch	1
11	240H-0340	Screw, Phillips, #8-12, Z	2
12	240H-0360	Bracket, Switch, ZY	1
13	240H-0350PAK2	Pak2, Switch, Engine, On/Off	1
14	99502H	Bearing, Ball	1
15	5100-088	Ring, Snap, External	1
16	AN-960-416L	Washer, Flat, 1/4, ZY	7
17	16040000	Washer, Lock, 1/4, ZY	7
18	18040000	Nut, Hex, 1/4-20, ZY	6
19	471442	Seal, Oil	1
20	55030400	BHSCS, #10-24 X 1/2, ZY	2
21	37040200	PHMS, 1/4-20 X 5/16, ZY	1
22	5677	Valve, Relief	1
23	240-0200	Stud, Mounting, M6 X 1/4-28	4
24	12040001	Nut, Hex, K-Lock, 1/4-28, ZY	4
25	90050-ZE1-000	PHST, M5 X 8, Z	2

*Replacement Parts Diagram  
Transmission Case Assembly  
242H Hole Digger  
[Beginning with Serial Number 174809]*

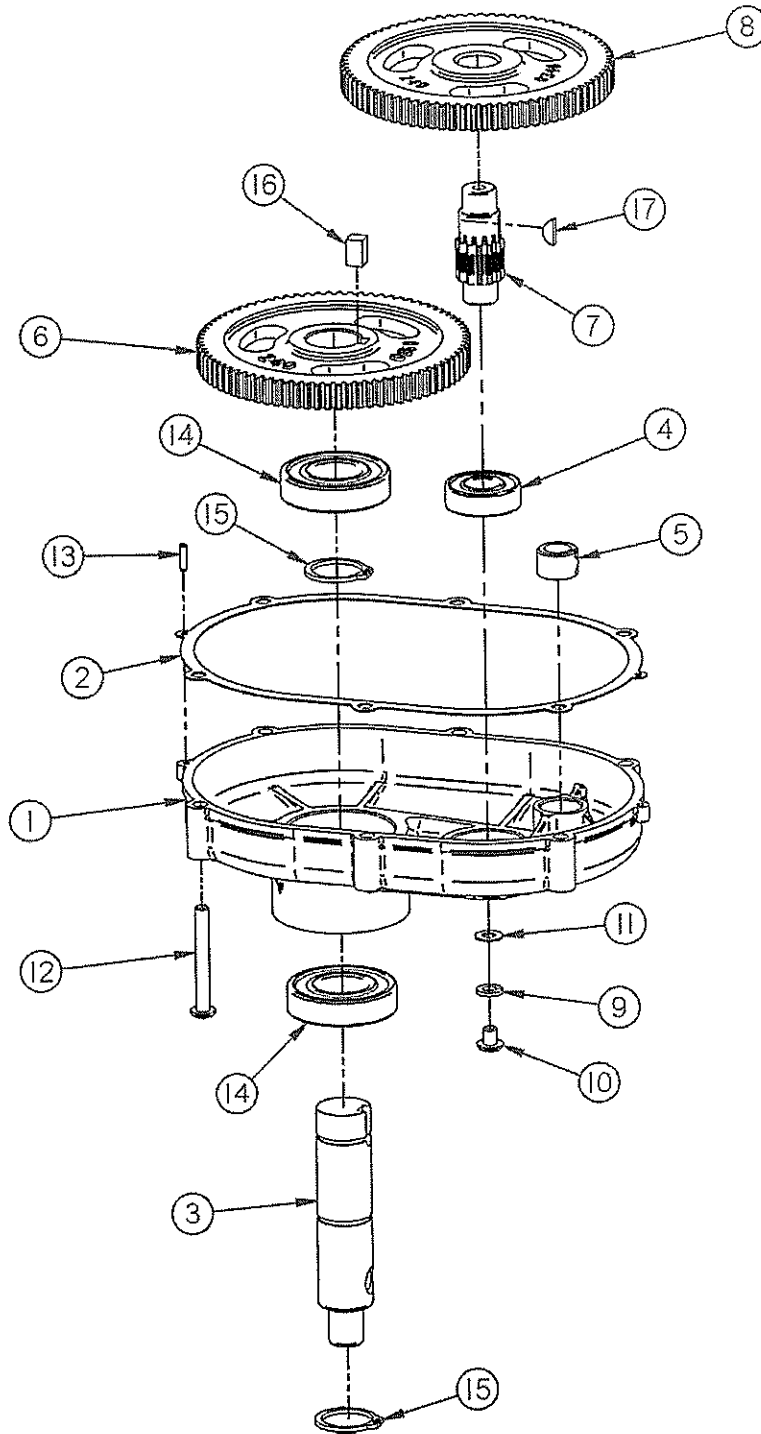

*Replacement Parts Diagram  
 Transmission Case Assembly  
 242H Hole Digger  
 [Beginning with Serial Number 174809]*

Reference Number	Part Number	Description	Quantity
1	242-0120A	Assembly, Case, Transmission, (Includes Ref. 4 & 5)	1
2	240-0100PAK2	Pak2, Gasket, Transmission	1
3	242-0330	Shaft, Drive, 1RD	1
4	99502H	Bearing, Ball	1
5	235-0140	Bushing, Spring-Type	1
6	240-0350	Gear, Secondary	1
7	210-0310	Gear, Pinion, Secondary	1
8	240-0340	Gear, Primary	1
9	16040000	Washer, Lock, 1/4, ZY	1
10	37040200	PHMS, 1/4-20 X 5/16, ZY	1
11	AN-960-416L	Washer, Flat, 1/4, ZY	1
12	34041600	Phrhms, 1/4-20 X 2, ZY	6
13	51020400	Pin, Dowl, 1/8 X 1/2	2
14	99R16	Bearing, Ball	2
15	5160-98	Ring, Snap	2
16	63050400	Key, Drive, Square, 5/16 X 1/2	1
17	3	Key, Woodruff, Alloy	1

# Replacement Parts Diagram Operator Handle Assembly 242H Hole Digger [Used With Serial Number 174809 Thru 179766]

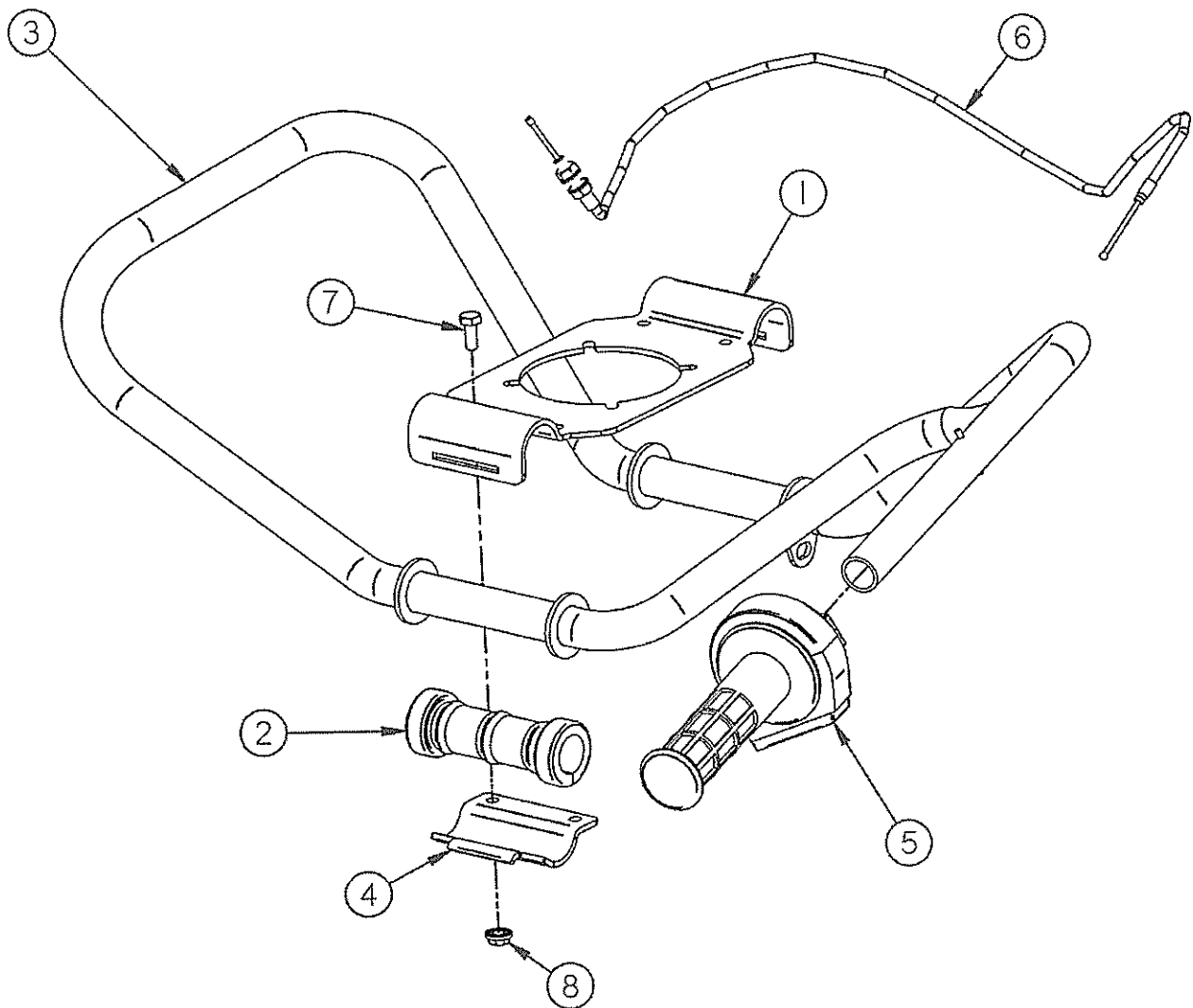

*Replacement Parts Diagram  
Operator Handle Assembly  
242H Hole Digger  
[Used With Serial Number 174809 Thru 179766]*

Reference Number	Part Number	Description	Quantity
1	242-0050	Bracket, Handle	1
2	242-0070	Bushing, Isolator, Handle	2
3	242-0090	Weldment, Handle, Operator	1
4	242-0060	Clamp, Handle	2
5	310-0030	Assembly, Control, Throttle	1
6	240H-0080PAK2	Pak2, Cable, Throttle	1
7	15040500	HHCS, 1/4-20 X 5/8, ZY	4
8	86040000	Nut, Hex, Flange, 1/4-20, ZY	4

# Replacement Parts Diagram Operator Handle Assembly 242H Hole Digger [Beginning with Serial Number 179767]

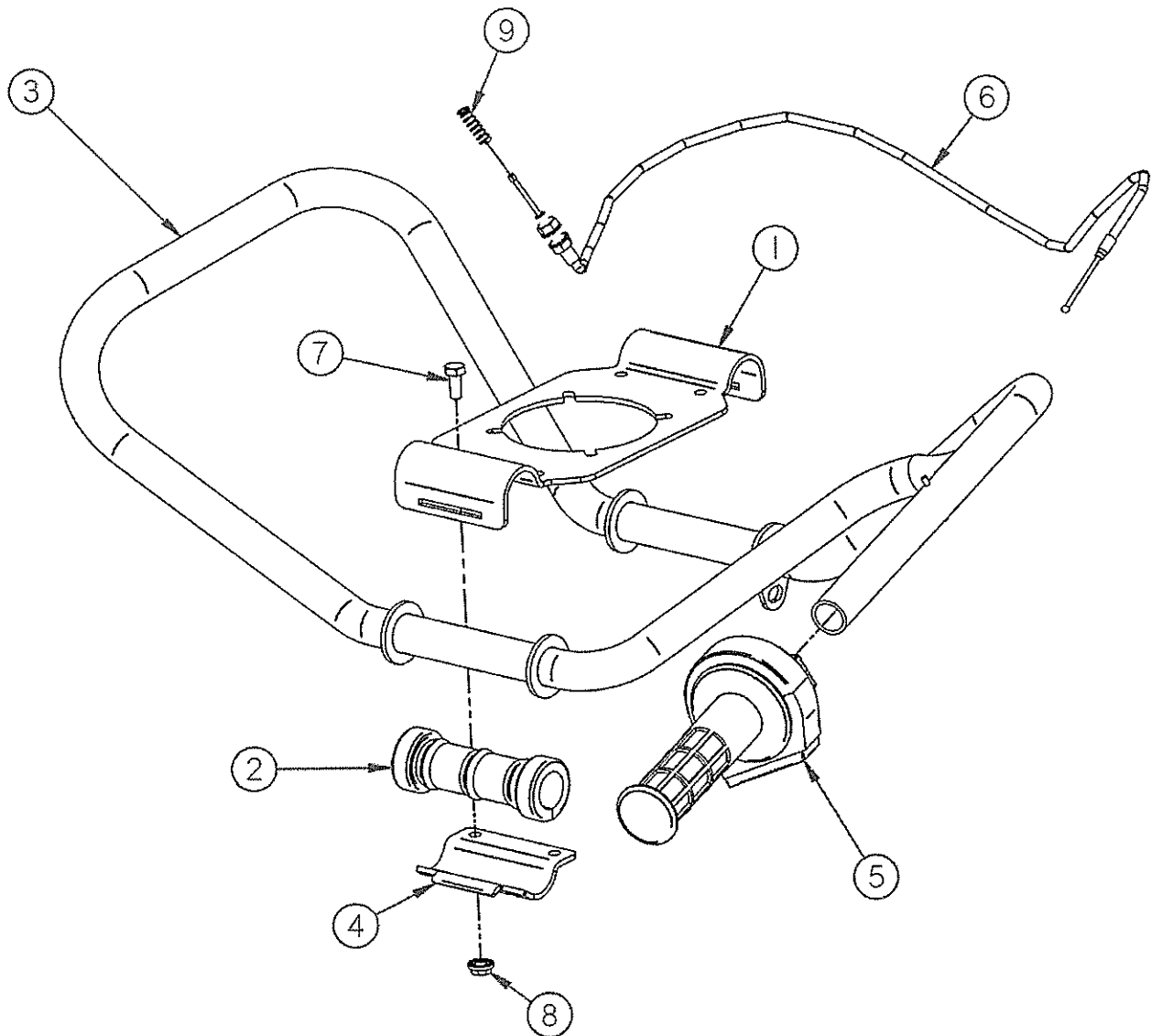

*Replacement Parts Diagram  
 Operator Handle Assembly  
 242H Hole Digger  
 [Beginning with Serial Number 179767]*

Reference Number	Part Number	Description	Quantity
1	242-0050	Bracket, Handle	1
2	242-0070	Bushing, Isolator, Handle	2
3	242-0090	Weldment, Handle, Operator	1
4	242-0060	Clamp, Handle	2
5	310-0030	Assembly, Control, Throttle	1
6	240H-0080PAK2	Pak2, Cable, Throttle, (Includes Ref. 9)	1
7	15040500	HHCS, 1/4-20 X 5/8, ZY	4
8	86040000	Nut, Hex, Flange, 1/4-20, ZY	4
9	242-0210	Spring, Return, Throttle, (Compatible With All 240H & 242H Models)	1

## Replacement Parts Diagram PN: 310-0030 Throttle Control Assembly For Use With 200 Series Hole Diggers

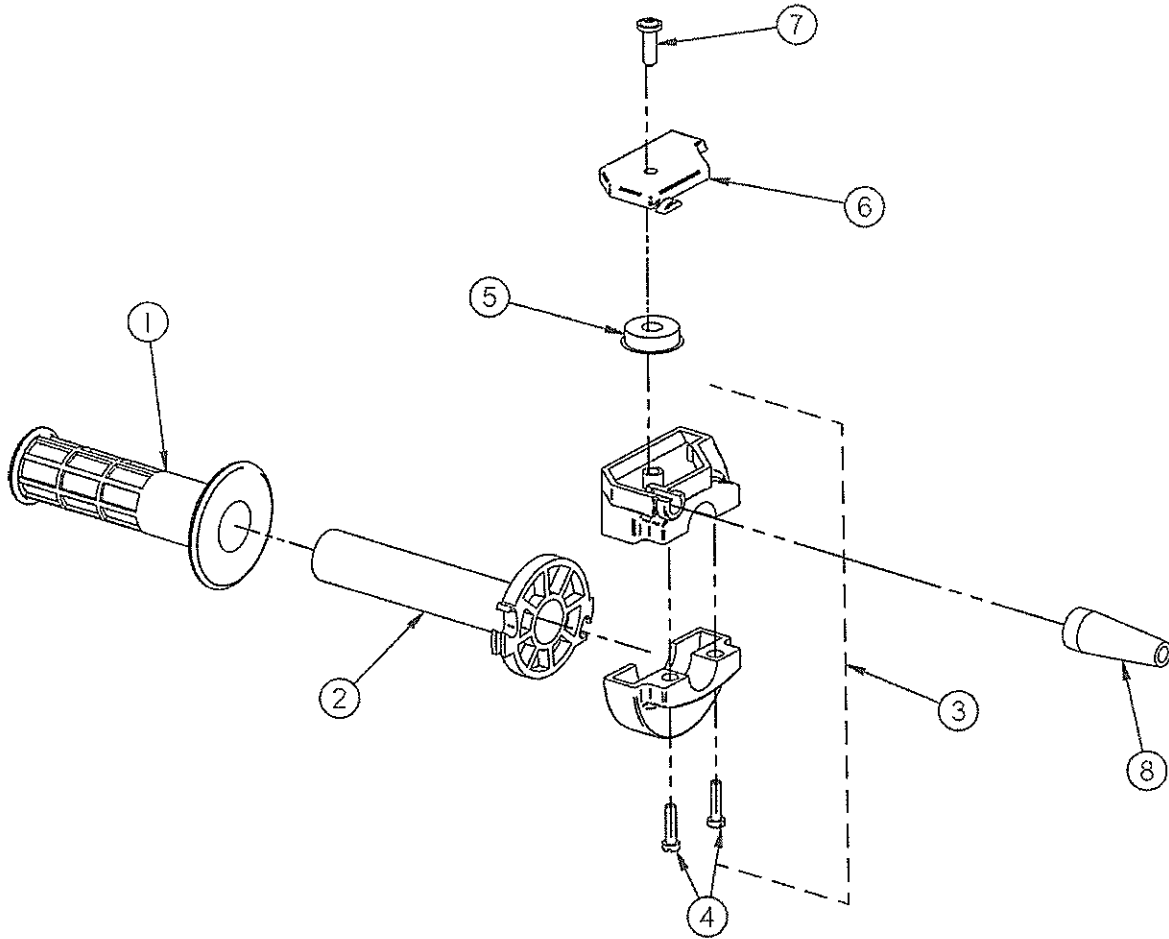

Reference Number	Part Number	Description	Quantity
1	310-0020-030	Grip, Throttle	1
2	310-0030-020-A	Tube, Throttle, W/Grip, (Includes Reference 1)	1
3	310-0030-010-A	Assembly, Body, W/Screws, (Includes Reference 4)	1
4	310-0030-040	Screw, Cheesehead, M5-.8 X 20	2
5	310-0030-070	Sheave, Roller	1
6	310-0030-060	Cover, Top	1
7	310-0030-050	Screw, Self-Tapping	1
8	310-0020-080	Boot, Rubber	1



# Replacement Parts Diagram Machine Decals 242H Hole Digger [Beginning with Serial Number 174809]

**General** CUSTOMER SERVICE INFORMATION  
EQUIPMENT & TOOL PARTS  
For further assistance, contact General Equipment Customer Service Team at no charge for the service number.

**SG24-5072**  
DECAL, ASSISTANCE

**WARNING**  
This is a warning decal that is used to alert the operator of a potential hazard. It is located on the back side of the engine. For more information, see the operator's manual.

**DANGER**  
CRACKS WHICH DEFORM PRODUCE DIFFERENTIAL CHANGE. CONTACT US FOR THE REPAIR PROCEDURE.

**240-5090**  
DECAL, DANGER

\*ON BACK SIDE OF ENGINE

**CHECK OIL LEVEL**  
ENGINE OIL CAPACITY: 2.2 oz (100ml)  
OIL FILLER CAP: 1/2 INCH  
CHECK ENGINE OIL LEVEL AS SHOWN, SAE 10W-30, API S3 OR LATER

**240H-5010**  
DECAL, LEVEL, OIL

**GECD-5060**  
DECAL, WARNING, PROP 65

\*ON BACK SIDE OF ENGINE

**CAUTION HOT**

**210-5041**  
DECAL, MUFFLER HOT

**General**

**GECD-5020**  
DECAL, GENERAL, 1.38 X 7.00

**READ BEFORE STARTING**  
ALWAYS OPERATE THE EQUIPMENT IN ACCORDANCE WITH THE INSTRUCTIONS PROVIDED IN THE OPERATOR'S MANUAL. ALWAYS WEAR YOUR SAFETY BELT AND SEATBELT. ALWAYS WEAR YOUR SAFETY GLASSES. ALWAYS WEAR YOUR SAFETY SHOES. ALWAYS WEAR YOUR SAFETY VEST. ALWAYS WEAR YOUR SAFETY HAT. ALWAYS WEAR YOUR SAFETY GLOVES. ALWAYS WEAR YOUR SAFETY CAP. ALWAYS WEAR YOUR SAFETY Goggles. ALWAYS WEAR YOUR SAFETY EARPLUGS. ALWAYS WEAR YOUR SAFETY EARPLUGS. ALWAYS WEAR YOUR SAFETY EARPLUGS.

**240-5020**  
DECAL, STARTING

**THIS MACHINE UTILIZES A 4-STROKE ENGINE. DO NOT MIX OIL WITH GASOLINE. CHECK CRANKCASE OIL LEVEL AS RECOMMENDED IN THE OPERATOR'S MANUAL.**

**240-5030**  
DECAL, 4 STROKE

**CAUTION**  
EYE AND EAR PROTECTION REQUIRED

**SP8-5041**  
DECAL, CAUTION, EYE/EAR

**CAUTION**  
AVOID INJURY  
When operating the machine, be sure to wear your seat belt and safety glasses. Always use proper lifting techniques. Do not drink and operate the machine. Do not operate the machine if you are under the influence of alcohol or drugs. Do not operate the machine if you are tired or drowsy. Do not operate the machine if you are ill or have a headache. Do not operate the machine if you are wearing a hat or sunglasses. Do not operate the machine if you are wearing a hat or sunglasses.

**210-5021**  
DECAL, CAUTION, AVOID INJURY

**FAMILY OWNED AMERICAN MADE**

**GECD-5050**  
DECAL, FAMILY OWNED, AMERICAN

**Auger LOK Procedure**  
1. Stop engine.  
2. Rotate, stop and lock Auger LOK pin to Easy Engage transmission gear.  
3. Rotate the Digger's engine clockwise by hand until Auger has been freed.  
4. Rotate, lift and lock Auger LOK pin to Easy Engage transmission gear.  
5. Control weight is free at all positions before resuming to dig.

**235-5020**  
DECAL, LOCK, AUGER

**MACHINE WEIGHT LESS AUGER 20 LBS (9 Kg)**

**240-5080**  
DECAL, WEIGHT

\*ON TRANSMISSION LOCK PLATE

**811**  
Call before you dig

**240-5100**  
DECAL, 811

*Replacement Parts Diagram  
 2350 Series Augers (2 Thru 8 Inch Diameter)  
 1 Inch Round Drive Connection  
 For Use With 200 Series Hole Digger*

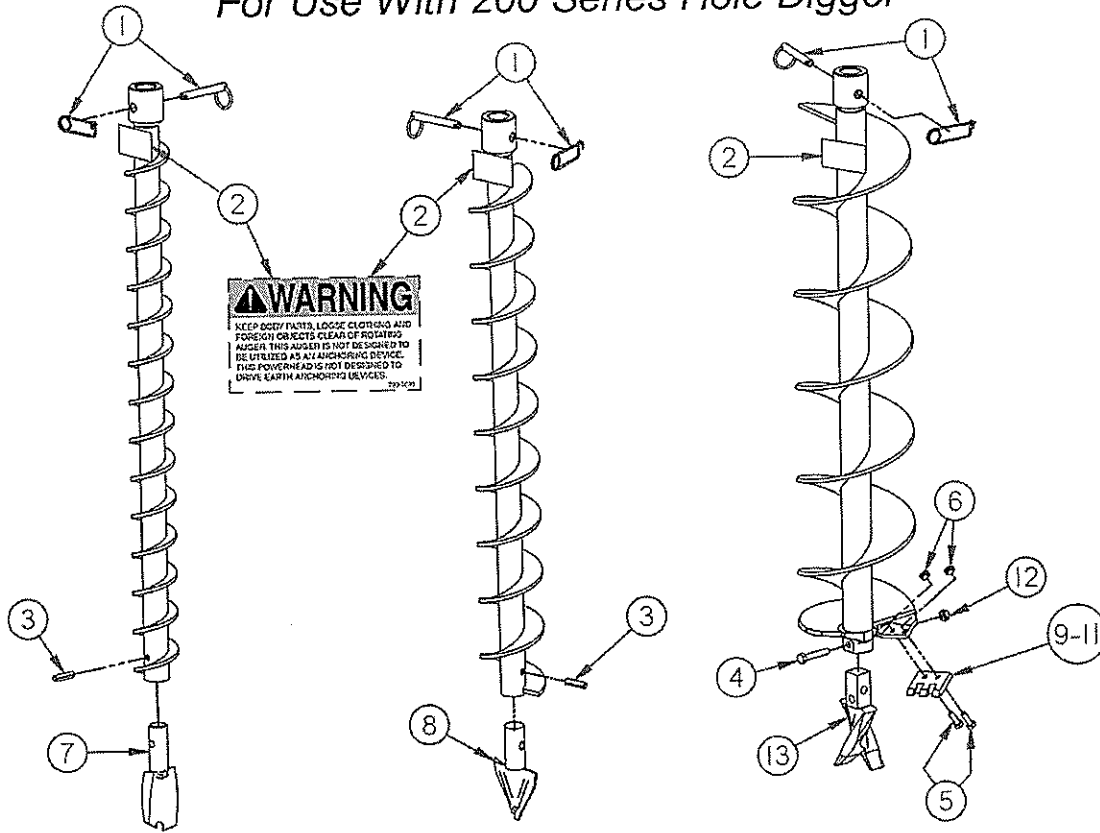

2350-2E, 2 Inch Diameter Auger

2350-3E, 3 Inch Diameter Auger

2350-4E, 4 Inch Diameter Auger  
 2350-6E, 6 Inch Diameter Auger  
 2350-8E, 8 Inch Diameter Auger

Reference Number	Part Number	Description	Application	Quantity
1	2121PAK3	Pak3, Pin, Auger, .375D	All Augers	1
2	233-5093	Decal, Caution, Clear Rotating	All Augers	1
3	20051000	Pin, Roll, 5/16 X 1-1/4	2350-2E, 2350-3E	1
4	15051300	HHCS, 5/16-18 X 1-5/8, ZY	2350-4E Thru 2350-8E	1
5	15040600	HHCS, 1/4-20 X 3/4, ZY	2350-4E Thru 2350-8E	2
6	52040000	Nut, Lock, 2-Way, 1/4-20, ZY	2350-4E Thru 2350-8E	2
7	P801PAK3	Pak3, Bit, Screw, Auger	2350-2E	1
8	P302PAK2	Pak2, Bit, Screw, Auger	2350-3E	1
9	E244PAK3	Pak3, Blade, Earth, 4D	2350-4E	1
10	E246PAK3	Pak3, Blade, Earth, 6D	2350-6E	1
11	E248PAK3	Pak3, Blade, Earth, 8D	2350-8E	1
12	52050000	Nut, Lock, 2-Way, 5/16-18, ZY	2350-4E Thru 2350-8E	1
13	SB26PAK3	Pak3, Bit, Screw, Auger, (Includes Ref. 4 & 12)	2350-4E Thru 2350-8E	1

THIS PAGE INTENTIONALLY  
LEFT BLANK



2  
4



3  
5

