

SKYJACK

SERVICE MANUAL

SJ45 AJ+

ARTICULATING BOOMS



238274ADA

February 11 2022
ANSI/CSA, CE, AS

This manual is for MEWPs with serial numbers:

SJ45 AJ+: A301 100 001 - A301 199 999

SJ45 AJ+: B301 100 001 - B301 199 999

Please refer to the website (www.skyjack.com) for contact information, other serial numbers, the most recent technical manuals, and USB software.

THIS SAFETY ALERT SYMBOL MEANS ATTENTION!



BECOME ALERT! YOUR SAFETY IS INVOLVED.

The Safety Alert Symbol identifies important safety messages on MEWPs, safety signs in manuals or elsewhere. When you see this symbol, be alert to the possibility of personal injury or death. Follow the instructions in the safety message.

 DANGER

DANGER indicates an imminently hazardous situation which, if not avoided, will result in death or serious injury.

 WARNING

WARNING indicates a potentially hazardous situation which, if not avoided, could result in death or serious injury.

 CAUTION

CAUTION indicates a potentially hazardous situation which, if not avoided, may result in minor or moderate injury. It may also be used to alert against unsafe practices.

IMPORTANT

IMPORTANT indicates a procedure essential for safe operation and which, if not followed, may result in a malfunction or damage to the MEWP.

Table of Contents

Section 1 – Scheduled Maintenance	11
1.1 Read and Heed	11
1.1-1 <i>MEWP and Mobile Elevating Work Platform Definition</i>	11
1.1-2 <i>Purpose of Equipment</i>	11
1.1-3 <i>Use of Equipment</i>	11
1.1-4 <i>Manual</i>	11
1.1-5 <i>Service Policy and Warranty</i>	11
1.1-6 <i>Operator Safety Reminders, Warnings and Precautions</i>	11
1.2 Maintenance and Service	12
1.2-1 <i>Maintenance and Inspection Schedule</i>	12
1.2-2 <i>Owner's Annual Inspection Record</i>	12
1.2-3 <i>Replacement Parts</i>	12
1.2-4 <i>Maintenance and Service Safety Tips</i>	12
1.2-5 <i>Hydraulic System & Component Maintenance and Repair</i>	13
1.2-6 <i>Hydraulic Maintenance Hints</i>	13
1.2-7 <i>Railing Maintenance and Repair</i>	14
1.3 Scheduled Maintenance	15
1.3-1 <i>Service Bulletins</i>	15
1.3-2 <i>Maintenance and Inspection</i>	15
1.3-3 <i>Maintenance Instructions</i>	15
1.4 Owner's Annual Inspection Record	16
1.5 Pre-Delivery/Maintenance Inspection Checklist	17
1.6 Scheduled Maintenance Inspections	18
1.6-1 <i>Electrical</i>	18
1.6-2 <i>Hydraulic</i>	18
1.6-3 <i>Labels</i>	18
1.6-4 <i>Limit switches</i>	18
1.6-5 <i>Engine Compartment</i>	19
1.6-6 <i>Control Compartment</i>	22
1.6-7 <i>Base</i>	24
1.6-8 <i>Platform</i>	26
1.6-9 <i>Boom Assembly</i>	27
1.6-10 <i>Optional equipment</i>	28
1.7 Function Tests	29
Section 2 – Maintenance Tables and Diagrams	31
2.1 Standard Hose Numbering System	31
2.2 Torque Specifications for Fasteners (US Imperial)	33

2.3	Torque Specifications for Fasteners (Metric)	34
2.4	Torque Specifications for Hydraulic Couplings & Hoses	35
2.5	MEWP Torque Specifications	36
2.6	Axle Torque Specifications	37
2.7	Axle Maintenance Intervals	38
2.8	Tire Specifications	39
2.9	Floor Loading Pressure	40
2.10	Hydraulic Specifications	41
2.11	MEWP Specifications	42
2.12	Platform Capacities	43
2.13	Fluids	44
2.14	Engines	44
2.15	Reach Diagram	45
2.16	Dimension Diagrams	46
2.17	Axle Oscillation Diagram	48
Section 3 – System Component Identification and Schematics		49
3.1	Electrical Symbol Chart	50
3.2	Hydraulic Symbol Chart	51
3.3	Wire Number and Colour Chart	52
3.4	Hydraulic Parts List	53
3.5	Electrical Parts List	56
3.6	Brake Manifold Components and Ports	59
3.7	Drive and System Pump Ports	60
3.8	Drive Motor Ports	61
3.9	Jib Valve Ports	62
3.10	Main Manifold Ports	63
3.11	Main Manifold Electrical Components	64
3.12	Main Manifold Hydraulic Components	65
3.13	Major Components	66
3.14	Main Harness and Fuel Level Switch Harness	67
3.15	Engine Harness - D1305	68
3.16	Engine Harness Wiring Diagram - D1305	69
3.17	Engine Harness - WG972	70
3.18	Engine Harness Wiring Diagram - WG972	71
3.19	Jib and Platform Rotate Harness	72
3.20	Limit Switch Connections	73
3.21	SGE Connections	74
3.22	Moba Load Cell Connections	75
3.23	Footswitch Connections	76
3.24	CANbus Cable Connections	77
3.25	Power Cable Connections	78
3.26	All Motion Alarm Connections - CE & AS	79

3.27	Flashing Amber Light Connections	80
3.28	Positive Air Shut-off Harness - Kubota D1305	81
3.29	Hydraulic Schematic	83
3.30	Platform Control Box Wiring	84
3.31	Base Control Box Wiring - ANSI/CSA & AS	85
3.32	Base Control Box Wiring - CE	86
3.33	Electrical Schematic - ANSI/CSA & AS	87
3.34	Electrical Schematic - CE	88
3.35	Engine Schematic - Kubota D1305	89
3.36	Engine Schematic - Kubota WG972	90
Section 4 – Troubleshooting Information		91
4.1	Introduction	91
4.2	Electrical System	92
4.2-1	All Controls are Inoperative from the Base or Platform Console	92
4.2-2	All Controls are Inoperative from the Base Console	94
4.2-3	The Engine will not Crank from the Base or Platform	94
4.2-4	The Engine will not Crank from the Base	95
4.2-5	The Engine will not Crank from the Platform	95
4.2-6	The Boom Controls are Inoperative (Drive Operates)	95
4.2-7	No Boom Up from the Base or Platform Controls	96
4.2-8	No Boom Up from the Base Console	96
4.2-9	No Boom Up from the Platform Console	96
4.2-10	No Boom Down from the Base or Platform Consoles	96
4.2-11	No Boom Down from the Base Console	97
4.2-12	No Boom Down from the Platform Console	97
4.2-13	No Turret Rotate Right from the Base or Platform Consoles	97
4.2-14	No Turret Rotate Right from the Base Console	97
4.2-15	No Turret Rotate Right from the Platform Console	98
4.2-16	No Turret Rotate Left from the Base or Platform Consoles	98
4.2-17	No Turret Rotate Left from the Base Console	98
4.2-18	No Turret Rotate Left from the Platform Console	98
4.2-19	No Riser Up from the Base or Platform Consoles	99
4.2-20	No Riser Up from the Base Console	99
4.2-21	No Riser Up from the Platform Console	99
4.2-22	No Riser Down from the Base or Platform Consoles	99
4.2-23	No Riser Down from the Base Console	100
4.2-24	No Riser Down from the Platform Console	100
4.2-25	No Telescope Out from the Base or Platform Consoles	100
4.2-26	No Telescope Out from the Base Console	100
4.2-27	No Telescope Out from the Platform Console	101
4.2-28	No Telescope In from the Base or Platform Consoles	101
4.2-29	No Telescope In from the Base Console	101

4.2-30	No Telescope In from the Platform Console	101
4.2-31	No Platform Level Up from the Base or Platform Consoles	102
4.2-32	No Platform Level Up from the Base Console	102
4.2-33	No Platform Level Up from the Platform Console	102
4.2-34	No Platform Level Down from the Base or Platform Consoles	102
4.2-35	No Platform Level Down from the Base Console	103
4.2-36	No Platform Level Down from the Platform Console	103
4.2-37	No Platform Rotate or Jib Functions from the Base or Platform Consoles	103
4.2-38	No Platform Rotate Right from the Base or Platform Consoles	104
4.2-39	No Platform Rotate Right from the Base Console	104
4.2-40	No Platform Rotate Right from the Platform Console	104
4.2-41	No Platform Rotate Left from the Base or Platform Consoles	105
4.2-42	No Platform Rotate Left from the Base Console	105
4.2-43	No Platform Rotate Left from the Platform Console	105
4.2-44	No Jib Up from the Base or Platform Consoles	105
4.2-45	No Jib Up from the Base Console	106
4.2-46	No Jib Up from the Platform Console	106
4.2-47	No Jib Down from the Base or Platform Consoles	106
4.2-48	No Jib Down from the Base Console	106
4.2-49	No Jib Down from the Platform Console	107
4.2-50	No Drive or Steer Functions	107
4.2-51	No Forward or Reverse Drive	107
4.2-52	No Forward Drive	107
4.2-53	No Reverse Drive	108
4.2-54	The Brake will not Release	108
4.2-55	No Left Steer	108
4.2-56	No Right Steer	109
4.2-57	The Directon Sensing is Inoperative	109
4.2-58	The Load Sense Indicates Overload or Overload Warning with the Platform Empty or Below Weight	110
4.2-59	The Overload Indicator Light does not Turn On when the Platform is Overloaded	110
4.2-60	The Audible Alarm does not Turn On with the Platform Overloaded	110
4.3	Hydraulic System	111
4.3-1	All Controls Inoperative	111
4.3-2	All Boom Functions Inoperative	111
4.3-3	No Main Boom Up	111
4.3-4	No Main Boom Down	112
4.3-5	No Riser Boom Up	112
4.3-6	No Riser Boom Down	113
4.3-7	Riser Boom Down Jerky	113
4.3-8	No Turret Rotate Left	113
4.3-9	No Turret Rotate Right	114
4.3-10	No Boom Extend	115

4.3-11	No Boom Retract	115
4.3-12	No Jib Up	115
4.3-13	No Jib Down	116
4.3-14	No Platform Rotation Right	116
4.3-15	No Platform Rotation Left	117
4.3-16	Platform will not Level Down Manually	117
4.3-17	Platform will not Level Up Manually	118
4.3-18	Brake will not Release	118
4.3-19	Brake will not Engage	119
4.3-20	Differential Lock will not Engage	119
4.3-21	No Drive Forward or Reverse	119
4.3-22	No Forward Drive	119
4.3-23	No Reverse Drive	120
4.3-24	No High Speed Drive	120
4.3-25	No Right Steer	120
4.3-26	No Left Steer	120
4.3-27	Axle Will Not Oscillate	120
4.3-28	Axle Will Not Lock	121

Section 5 – Procedures 123

5.1	General	123
5.1-1	Safety and Workmanship	123
5.2	Platform	124
5.2-1	Human Machine Interface (HMI)	124
5.2-2	User Interface Keys	124
5.2-3	SCM Character Functions Charts	125
5.2-4	SCM Function Channel Names	125
5.2-5	SCM Pin Reference	126
5.2-6	SCM Recommended Settings - Kubota WG972 Dual Fuel Engine	132
5.2-7	Default Recommended Settings - Kubota D1305 Diesel Engine	133
5.2-8	Unlock and Modify the SCM	134
5.2-9	SCM Model Select	135
5.2-10	Check I/O Error	137
5.2-11	SCM Calibration	138
5.2-12	SCM Calibration Flowchart	139
5.2-13	CAN Bus Communication Check	140
5.2-14	Fly Boom Switch Voltage References	141
5.2-15	Platform Controller Voltage References	142
5.3	Boom	143
5.3-1	Check Wear Pads	143
5.3-2	Shim Wear Pads	143
5.3-3	Cable Carrier Repair	143
5.3-4	Rotary Actuator Bolt Torque Procedure	143

	5.3-5	Master Cylinder Replacement	144
	5.3-6	Limit Switch Locations	145
5.4		Turret	146
	5.4-1	Check and Replace the High Pressure Filter	146
	5.4-2	Turret Rotation Gear Bolt Torque Sequence	146
	5.4-3	Electronic Tilt Switch Setup Procedure	147
	5.4-4	Battery Replacement	149
5.5		Diesel Engine	150
	5.5-1	Replace Engine Oil and Filter	150
	5.5-2	Replace the Fuel Filter	151
	5.5-3	Replace the Air Filter	151
	5.5-4	Check the Engine Belt	151
5.6		Hydraulic Tank	152
	5.6-1	Hydraulic Oil Replacement	152
	5.6-2	Hydraulic Filter Replacement	152
5.7		Manifold and Hydraulic Pumps	153
	5.7-1	Hydraulic Brake Pressure Adjustment	153
	5.7-2	Hydraulic System Relief Valve Adjustment	154
	5.7-3	Riser Down Relief Valve Adjustment	154
	5.7-4	Turret Rotate Relief Valve Adjustment	155
	5.7-5	Platform Level Relief Valve Adjustment	155
	5.7-6	Test Charge Pump Pressure on Drive Pump	156
	5.7-7	Test Forward Drive Pressure on Drive Pump	156
	5.7-8	Test Reverse Drive Pressure on Drive Pump	157
5.8		Axles	158
	5.8-1	Change the Oil in the Axles	158
	5.8-2	Check the Oil Level in the Torque Hubs	158
	5.8-3	Change the Oil in the Torque Hubs	158
	5.8-4	Check the Oil Level in the Axle Gearbox	159
	5.8-5	Change the Oil in the Axle Gearbox	159
	5.8-6	Oscillating Cylinder Bolt Replacement	160
	5.8-7	Oscillating Cylinder Replacement	160
	5.8-8	Bleed the Oscillating Axle Cylinders	162
	5.8-9	Test the Oscillating Axle Cylinders	162
	5.8-10	Pin Brake Adjustments	163
	5.8-11	Brake Inspection	164
	5.8-12	Axle U-Bolt Torque	165
5.9		Grease Points	166
	5.9-1	Grease the Turret Ring Gear	166
	5.9-2	Grease the Axles	167
	5.9-3	Grease the Drive Shaft	167

Section 1 – Scheduled Maintenance

1.1 Read and Heed

Skyjack is continuously improving and expanding product features on its equipment, therefore, specifications and dimensions are subject to change without notice.

1.1-1 MEWP and Mobile Elevating Work Platform Definition

A mobile device that has a positionable platform supported from ground level by a structure.

1.1-2 Purpose of Equipment

The Skyjack Articulated Boom Series MEWPs are designed to transport and raise personnel, tools and materials to overhead work areas.

1.1-3 Use of Equipment

The MEWP is a highly maneuverable, mobile work station. Work platform elevation and elevated driving must only be done on a firm, level surface.

1.1-4 Manual

Operating Manual: The operating manual is considered a fundamental part of the MEWP. It is a very important way to communicate necessary safety information to users and operators. A complete and legible copy of this manual must be kept in the provided weather-resistant storage compartment on the MEWP at all times.

Service & Maintenance: The purpose of this is to provide the customer with the servicing and maintenance procedures essential for the promotion of proper machine operation for its intended purpose.

All information in this manual should be read and understood before any attempt is made to service the machine. The updated copy of the manuals are found on the company's website: www.skyjack.com.

1.1-5 Service Policy and Warranty

Skyjack warrants each new product to be free of defective parts and workmanship for the first 2 years or 3000 hours, whichever occurs first. Any defective part will be replaced or repaired by your local Skyjack dealer at no charge for parts or labor. In addition, all products have a 5 year structural warranty. Contact the Skyjack Service Department for warranty statement extensions or exclusions.

1.1-6 Operator Safety Reminders, Warnings and Precautions

Operator safety is Skyjack's priority. The operator should comply with all applicable safety-related reminders, warnings and precautions found in the Operating Manual. They should be read and understood completely before operating the MEWP.

1.2 Maintenance and Service

1.2-1 Maintenance and Inspection Schedule

The actual operating environment of the work platform governs the use of the maintenance schedule. The inspection points covered in [Table 1.2. Maintenance and Inspection Checklist](#), indicates the areas of the MEWP to be maintained or inspected and at what intervals the maintenance and inspections are to be performed.

1.2-2 Owner's Annual Inspection Record

It is the responsibility of the owner to arrange quarterly and annual inspections of the MEWP. The Owner's Annual Inspection Record ([1.4 Owner's Annual Inspection Record](#)) is to be used to record the date of the inspection, owner's name, and the person responsible for the inspection of the work platform.

1.2-3 Replacement Parts

Use only original replacement parts. Parts such as batteries, wheels, railings, etc. with weight and dimensions different from original parts will affect stability of the MEWP and must not be used without manufacturer's consent.

All replacement tires must be of the same size and load rating as originally supplied tires; to maintain safety and stability of MEWP.

Consult Skyjack's Service Department for optional tires specifications and installation.

WARNING

Any unit that is damaged or not operating properly must be immediately tagged and removed from service until proper repairs are completed.

1.2-4 Maintenance and Service Safety Tips

Maintenance and repair should only be performed by personnel who are trained and qualified to service this MEWP.

All maintenance and service procedures should be performed in a well lighted and well ventilated area.

Anyone operating or servicing this MEWP must read and completely understand all operating instructions and safety hazards in this manual and operating manual.

All tools, supports and lifting equipment to be used must be of proper rated load and in good working order before any service work begins. Work area should be kept clean and free of debris to avoid contaminating components while servicing.

Ensure personnel are clear from under unsupported components/systems that are at risk of movement during maintenance.

All service personnel must be familiar with employer and governmental regulations that apply to servicing this type of equipment.

Keep sparks and flames away from all flammable or combustible materials.

Properly dispose of all waste material such as lubricants, rags, and old parts according to the relative law provisions obtaining in the country.

Before attempting any repair work, disconnect the main power connectors.

Keep personnel clear of components, systems or unsupported loads that may move unexpectedly during maintenance procedures.

Preventive maintenance is the easiest and least expensive type of maintenance.

1.2-5 Hydraulic System & Component Maintenance and Repair

The following points should be kept in mind when working on the hydraulic system or any component:

WARNING

Escaping fluid from a hydraulic pressure leak can damage your eyes, penetrate the skin and cause serious injury. Use proper personal protection at all times.

1. Any structure has limits of strength and durability. To prevent failure of structural parts of hydraulic components, relief valves which limit pressure to safe operating values are included in the hydraulic circuits.
2. Tolerance of working parts in the hydraulic system is very close. Even small amounts of dirt or foreign materials in the system can cause wear or damage to components, as well as general faulty operation of the hydraulic system. Every precaution must be taken to assure absolute cleanliness of the hydraulic oil.
3. Whenever there is a hydraulic system failure which gives reason to believe that there are metal particles or foreign materials in the system, drain and flush the entire system and replace the filter cartridges. A complete change of oil must be performed under these circumstances.
4. Whenever the hydraulic system is drained, check the magnets in the hydraulic reservoir for metal particles. If metal particles are present, flush the entire system and add a new change of oil. The presence of metal particles also may indicate the possibility of imminent component failure. A very small amount of fine particles is normal.
5. All containers and funnels used in handling hydraulic oil must be absolutely clean. Use a funnel when necessary for filling the hydraulic oil reservoir, and fill the reservoir only through the filter opening. The use of cloth to strain the oil should be avoided to prevent lint from getting into the system.
6. When removing any hydraulic component, be sure to cap and tag all hydraulic lines involved. Also, plug the ports of the removed components.

7. All hydraulic components must be disassembled in spotlessly clean surroundings. During disassembly, pay particular attention to the identification of parts to assure proper reassembly. Clean all metal parts in a clean mineral oil solvent. Be sure to thoroughly clean all internal passages. After the parts have been dried thoroughly, lay them on a clean, lint-free surface for inspection.
8. Replace all O-rings and seals when overhauling any component. Lubricate all parts with clean hydraulic oil before reassembly. Use small amounts of petroleum jelly to hold O-rings in place during assembly.
9. Be sure to replace any lost hydraulic oil when completing the installation of the repaired component, and bleed any air from the system when required.
10. All hydraulic connections must be kept tight. A loose connection in a pressure line will permit the oil to leak out or air to be drawn into the system. Air in the system can cause damage to the components and noisy or erratic system operation.

1.2-6 Hydraulic Maintenance Hints

Three simple maintenance procedures have the greatest effect on the hydraulic system performance, efficiency and life. Yet, the very simplicity of them may be the reason they are so often overlooked. They are simply these:

1. Change filters annually. The filters will need to be changed more often depending on the operating conditions. Dirty, dusty, high moisture environments may cause the hydraulic system to be contaminated more quickly.
2. Maintain a sufficient quantity of clean hydraulic oil of the proper type and viscosity in the hydraulic reservoir.
3. Keep all connections tight.

1.2-7 Railing Maintenance and Repair

Skyjack MEWPs have been designed to ensure compliance with the relevant design standards applicable for that particular unit at the time of manufacture. As such, any repairs made to the guardrail or basket structure need to ensure this compliance is not compromised and must return the structure to its original condition.

Any damage must be repaired by returning the railing assembly to its undamaged state. Damage includes, but is not limited to, the items listed below:

- bent/deformed guardrail sections
- cracks or broken welds in railing sections
- damaged pin connections
- missing pins or broken pin lanyards
- missing railing hardware
- loose or missing parts
- additional holes in guardrail sections other than those approved by Skyjack

Additionally, the guardrails must be properly positioned and secured, and the entry gate must be in good working order.

The strength of the guardrail system, and therefore its ability to provide fall protection for platform occupants, depends upon the design being secure and undamaged.

Skyjack railings are designed for modular replacement, and Skyjack recommends replacement of any damaged railing section. Skyjack-approved replacement parts will meet this requirement.

1.3 Scheduled Maintenance

This section contains the maintenance and inspection schedule that is to be performed.

References are made to the procedures in Section 5 that outline detailed step-by-step instructions for checks and replacements.

1.3-1 Service Bulletins

Before performing any scheduled maintenance inspection procedure, refer to service bulletins found in our web site: www.skyjackinc.com for updates related to service and maintenance of this MEWP.

1.3-2 Maintenance and Inspection

Death or injury can result if the MEWP is not kept in good working order. Inspection and maintenance should be performed by competent personnel who are trained and qualified on maintenance of this MEWP.

WARNING

Failure to perform each procedure as presented and scheduled may cause death, serious injury or substantial damage.

NOTE

Preventive maintenance is the easiest and least expensive type of maintenance.

- Unless otherwise specified, perform each maintenance procedure with the MEWP in the following configuration:
 - MEWP parked on a flat and level surface
 - Disconnect the batteries by disconnecting the main power connectors.
- Repair any damaged or malfunction components before operating MEWP.
- Keep records on all inspections.

1.3-3 Maintenance Instructions

This manual consists of four schedules to be done for maintaining on a MEWP. Inspection schedule frequency is shown below:















Issue or Symptom		
PDI/Frequent	B	Perform PDI prior to each delivery, or Frequent Inspection every 200 days or 200 hours.
Annual	B + C	Perform Scheduled Maintenance Inspections every year.
Additional	*	Perform at time sensitive maintenance intervals.

- Make copies of the maintenance and inspection checklist to be used for each inspection.
- Check the schedule on the checklist for the type of inspection to be performed.
- Place a check in the appropriate box after each inspection procedure is completed.
- Use the maintenance and inspection checklist and step-by-step procedures in Section 1 to perform these inspections.
- If any inspection receives a fail, tag and remove the MEWP from service.
- If any MEWP component(s) has been repaired, an inspection must be performed again before removing the tag. Place a check in the repair column.

Legend

Pass	P
Fail	F
Repaired	R
Not applicable	N/A

Table 1.4 Owner's Annual Inspection Record

 Model _____ SN _____											
Inspection Date 											
	20	20	20	20	20	20	20	20	20	20	20
Inspector Signature 											
											

⚠ WARNING

Do not use the MEWP if there is no inspection recorded in the last 13 months. If you do not obey, there is a risk of death or serious injury.

IMPORTANT

The Owner's annual inspection record is located on the scissor assembly. It must be filled out after an annual inspection has been completed. Do not use the MEWP if an inspection has not been recorded in the last 13 months.

1.5 Pre-Delivery/Maintenance Inspection Checklist



Frequent/Periodic/Annual/PDI Checklist Articulating Booms and Telescopic Booms

Serial Number: Starting with serial number A000 000 000 or B000 000 000 and above

Product Owner: _____

Model: _____

Product User: _____

Hourmeter Reading: _____

Date/Time: _____

Inspection Type (Choose one): Pre-delivery Frequent Periodic Annual

Use this table for pre-delivery inspections (PDI) before each rental, lease or sale and as an instruction for all frequent inspections and annual inspections. Refer to the operation and service manuals for inspection instructions (for example, visual inspection and function tests, torque specs, engine oil, chain inspection intervals, and more).

Inspection Type Schedule	
PDI/Frequent/Periodic	B
Annual	B+C

B - Do the pre-delivery inspection before the machine is sent out or during the frequent inspections at 200 days or 200 hour intervals. For more instructions, refer to the operation and service manuals. **P** - Pass
N/A - Not Applicable
C - Do the scheduled maintenance inspections each year. For more instructions, refer to the service manual.

Put a check mark in the "Pass" column as you meet the requirements of the inspection for each item. Add a comment if the item does not pass inspection.

Items for Inspection	P	N/A
Service Bulletins. Make sure there are no open service bulletins.	B	
Annual Inspection. Make sure you complete it within 13 months.	B	
Labels. In place, correctly attached and you can read them.	B	
Limit Switches. Correctly installed and no obstructions or damage.	B	
ENGINE COMPARTMENT		
Main Power Disconnect Switch. Cables and switch tight and in working order.	B	
Battery. No damage, tight connections and sufficient fluid levels. Clean terminals and cable ends.	B	
Swing Drive. Tight fittings, hoses and bolts; No damage, missing components or leaks.	B	
Hydraulic Pump and Motor. Tight fittings, hoses and bolts. No damage, missing components or leaks.	B	
Engine and Components. Do a check of the engine and components for any loose, missing, damaged, or failed items. Do a check of the oil and coolant levels. Make sure you do not exceed the recommended oil and coolant change intervals.	B	
Air Filter. Do a check of the filter. Replace the air filter if necessary.	C	
Fuel Filter. Do a check of the filter. Replace the fuel filter if necessary.	C	
Radiator. Do a check of the coolant condition and replace if necessary.	C	
CONTROL COMPARTMENT		
Turret Transportation Lock. Unlocked and no damage or missing components.	B	
Base Control Console. Operate the switches and make sure they all operate correctly. No damage or missing components.	B	
Hydraulic Tank. Filler cap closed tightly and no damage or leaks.	B	
Hydraulic Oil. Level between min. and max. marks.	B	
Hydraulic Oil. Do a check and replace oil and filters if necessary.	C	
Hydraulic Return Filter. Correctly attached and no damage, missing components or leaks.	B	
Hydraulic Return Filter. Do a check of the filter. Replace the filter if necessary.	C	
Manifolds. Tight fittings and hoses and no damage or leaks. Tight wire connections, no missing components and correctly working valves.	B	
High-pressure Filter. Do a check of the filter. Replace the filter if necessary.		
Emergency Power Unit. Tight fittings and hoses. No leaks. Tight wire connections and no damage or missing components.	B	
Fuel Tank and Lines. Filler cap, tank, fittings and hoses are closed tightly and no damage or leaks.	B	
BASE		
Base Weldment. No deformation or cracks.	B	
Rotary Manifold. Tight fittings and hoses, and no leaks.	B	
Turret Rotation Motor/Gear. Tight fittings, hoses and bolts. No damage, missing components or leaks. Make sure the gears are lubricated.	B	
Turret Rotation Motor/Gear. Lubricate the gears.	C	

Items for Inspection	P	N/A
Axles. Correctly attached and no missing components. Tight fittings and hoses and no leaks.	B	
Axles. Do a check of the brakes.	C	
Oscillating Cylinders. Correctly attached and no missing components. Tight fittings and hoses and no leaks.	B	
Oscillating Cylinders. Correctly attached and no missing components. Tight fittings and hoses and no leaks. Do a check of the mounting bolts torque seal.	C	
Steer Cylinder. Correctly attached and no missing components. Tight fittings and hoses and no leaks.	B	
Steer Linkage. No damage/wear or missing components.	B	
Wheel/Tire Assembly. Do a check of all tires for damage, wear and correctly aligned.	B	
Wheel/Tire Assembly. No loose bolts. Wheel nuts torqued as recommended.	C	
PLATFORM		
Railings and Gates. Correctly attached and no damage or missing components.	B	
Platform Floor. Correctly attached and no damage or missing components.	B	
Footswitch. Correctly attached. Operates correctly with no modifications.	B	
Fall-Protection Anchorage. Anchorages are correctly attached and no damage.	B	
AC Power Socket. No obstructions, dirt, or damage	B	
Platform Control Console. Operate the switches and make sure they all operate correctly. No damage or missing components.	B	
Manual Storage Box. Manuals and documents are in the storage the box, in good condition, and you can read them.	B	
BOOM		
Rotary Actuator. No damage or missing components. Tight fittings, hoses and bolts and no leaks.	B	
Jib. No damage or missing components. Tight hoses and bolts and no leaks	B	
Boom. No damage or missing components. No deformation or cracks in welds. Tight fittings, hoses, bolts, and pins. No leaks.	B	
Cable Track. No damage or missing components	B	
Wear Pads. No damage, wear or missing components. Fasteners tight.	B	
Riser. No damage or missing components. No deformation or cracks in welds. Tight fittings, hoses, bolts, and pins. No leaks.	B	
Cylinders. No damage or missing components. Tight fittings and hoses and no leaks. Pins and bushing are tight and correctly installed.	B	
Control Cables and Hoses. No damage or missing components. No leaks.	B	
Wire Ropes. No damage or missing components. Tight jam nuts. No spring gaps. Do not exceed the inspection interval.	B	
OPTIONAL EQUIPMENT		
Special Options and Approved Attachments. Correctly attached and no damage or missing components.	B	
Function Tests. Refer to the operating manual for your serial number for information on how to run these tests:		
		PASS
		FAIL

199342AA

Comments: _____

The undersigned has made sure that all areas in the list have received an inspection.
The undersigned has told the machine owner of all inconsistencies in the inspection and corrected them before machine operation.

Owner: _____

User: _____

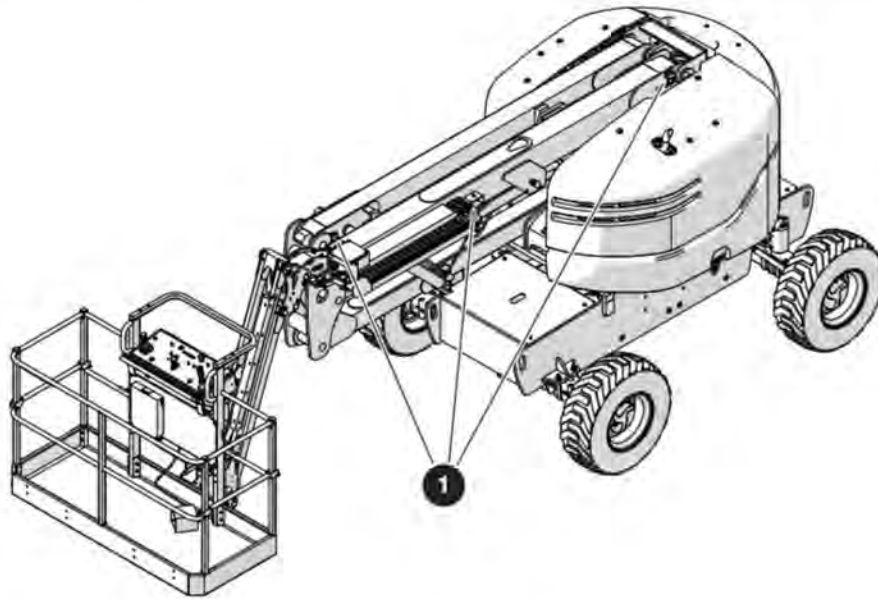

1.6 Scheduled Maintenance Inspections

Do an inspection of the MEWP in this sequence.

⚠ WARNING

Do not operate a MEWP until all malfunctions have been corrected. If you do not obey, there is a risk of death or serious injury.

⚠ WARNING

Turn the main power disconnect switch to the off position before you do the visual and daily maintenance inspections. If you do not obey, there is a risk of death or serious injury.

1.6-1 Electrical

Do a check on these areas for chafed, corroded, and loose wires:

- Boom to platform cable harness
- Engine compartment electrical panel
- Engine wiring harness
- Rotary manifold wiring

1.6-2 Hydraulic

Do a check on these areas and make sure there are no signs of leakage:

- Hydraulic tank filter, fittings, hoses, emergency-power unit, turret and base surface
- Engine compartment fittings, hoses, primary pump, filter, turret and base surface
- All hydraulic cylinders
- All hydraulic manifolds
- The ground area below the MEWP.

1.6-3 Labels (B)

Refer to the labels section in the Operating Manual. Make sure all the labels are in the correct location, are in good condition, and you can read them.

1.6-4 Limit switches (B)

Do an inspection of all limit switches ① located inside the turret and on the boom. Inspect for the following:

- Broken or missing actuator arms
- Missing fasteners
- Loose wiring.

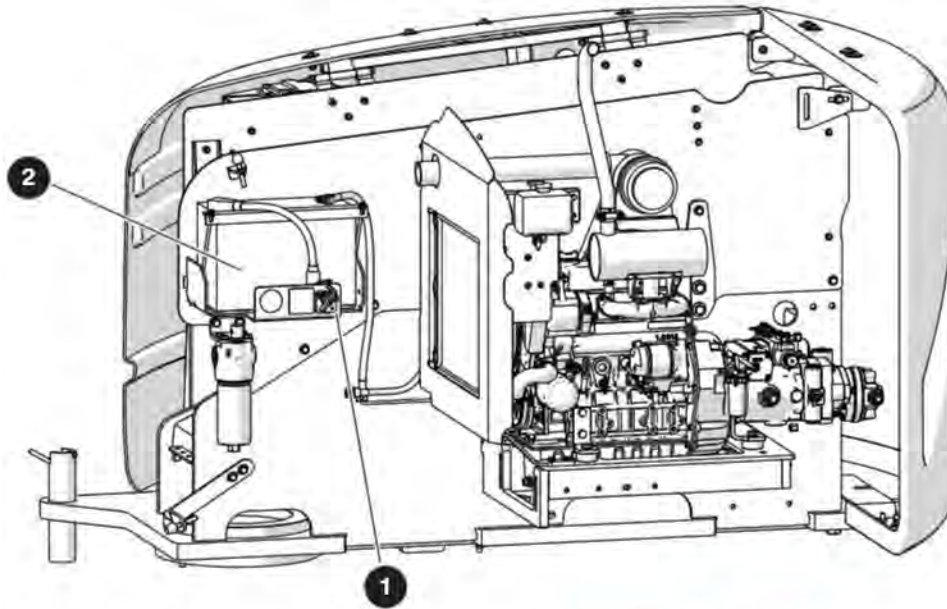

1.6-5 Engine Compartment

Do the inspection that follows:

Make sure all compartment latches are latched tightly and in good condition.

1 Main power disconnect switch (B)

- Turn the **main power disconnect** switch to the off position.
- Make sure the switch rotates and stays in the on and off position.
- Make sure the cables are not loose.

2 Battery (B)

B - Frequent Inspection

1. Do an inspection of the battery case for damage.
 - Clean the battery terminals and cable ends thoroughly with a terminal cleaning tool or wire brush.
2. Make sure all the battery connections are tight.
3. If applicable, check the battery fluid level.
 - If the plates do not have a minimum 13 mm (1/2 inch) of solution above them, add distilled or demineralized water.
 - Replace the battery if it is damaged or cannot hold a lasting charge.

WARNING

Explosion hazard. Keep flames and sparks away. Do not smoke near the batteries. If you do not obey, there is a risk of death or serious injury.

WARNING

Only use original or manufacturer-approved parts and components for the MEWP. If you do not obey, there is a risk of death, serious injury, or machine damage.

WARNING

Corrosion hazard. Do not touch battery acid. Wear the correct PPE. If the battery acid touches you, immediately flush the area with cold water and get medical aid.

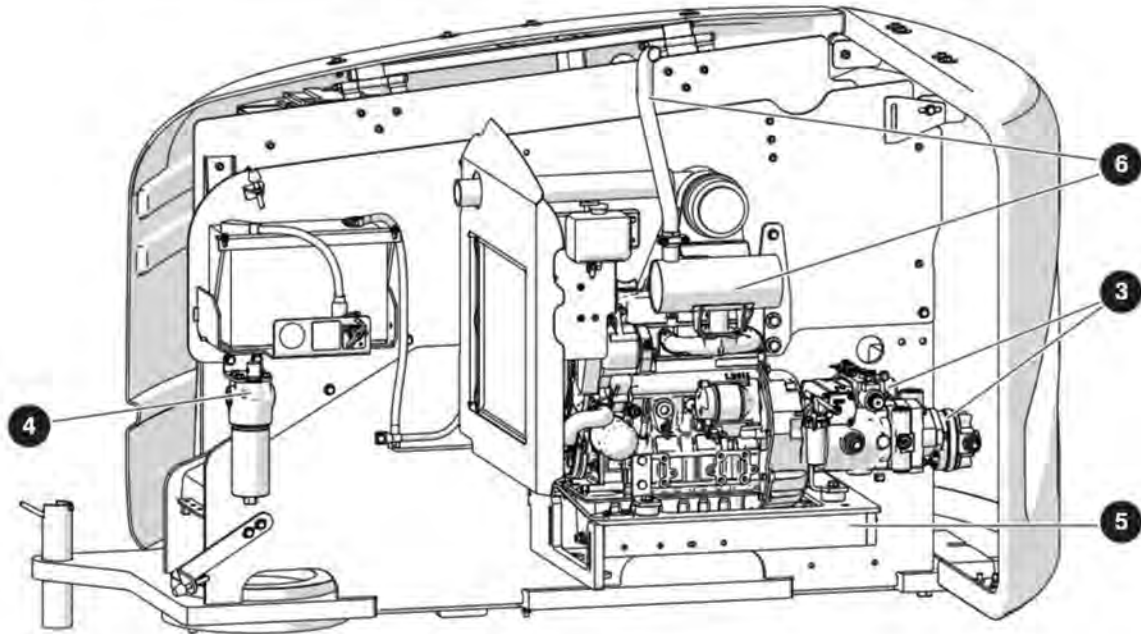

3 Hydraulic pump and motor (B)

- Make sure there are no loose or missing parts.
- Make sure there is no visible damage.
- Make sure all bolts are correctly tightened.
- Make sure all fittings and hoses are correctly tightened and there are no hydraulic leaks.

4 High-pressure filter (B,C)

- Make sure the housing is attached and tight.
- Make sure there is no visible damage or hydraulic leaks.

C - Annual Inspection

- For the filter element replacement procedure, refer to 5.4-1 [Check and Replace the High Pressure Filter](#).

Engine and Components

5 Engine tray (B)

- Make sure there are no loose or missing parts.
- Make sure there is no visible damage.
- Make sure that the engine is correctly attached to the pivot tray.
- Make sure the tray-securing bolt is in place.

6 Muffler and exhaust (B)

- Make sure that the muffler and exhaust systems are correctly attached with no visible damage.

Engine fuel leaks (B,C)

- Make sure that there no fuel leaks at the engine.
- Make sure there is no visible damage.

WARNING

Explosion or fire hazard. Do not smoke near the fuel system. If you do not obey, there is a risk of death or serious injury.

Engine fuel filter (B,C)

- Make sure there are no loose or missing parts.
- Make sure there is no visible damage.

C - Annual Inspection

- For the engine fuel filter replacement procedure, refer to the engine manual.

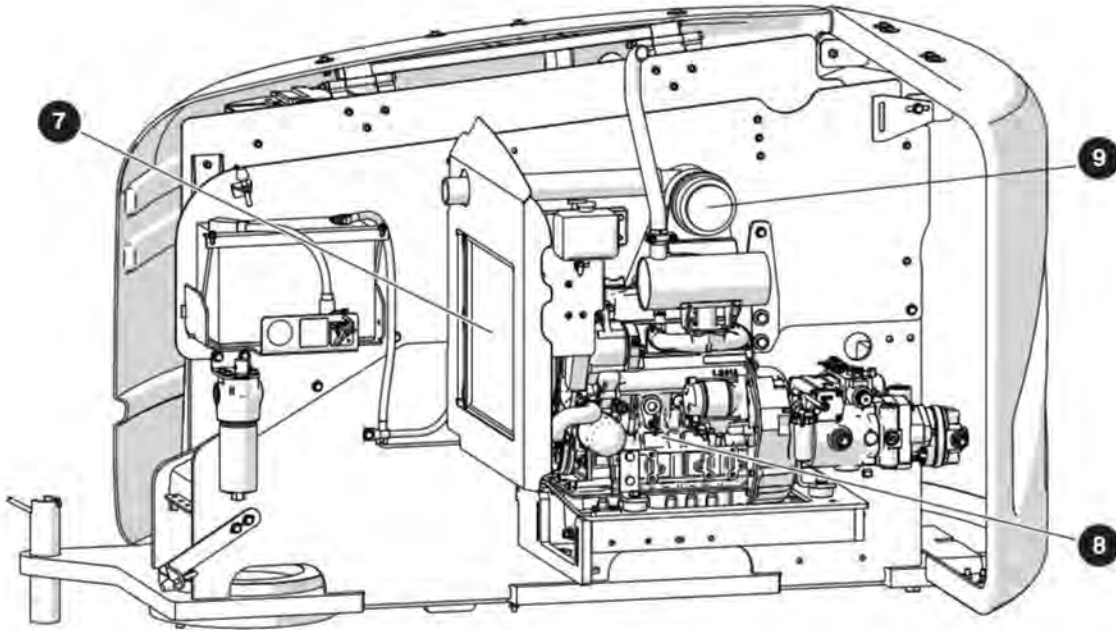

7 Radiator (B, C)

- Make sure there are no loose or missing parts.
- Make sure there is no visible damage.
- Make sure that the radiator is correctly attached to the engine tray.
- Check the coolant level and add more if necessary.

C - Annual Inspection

- Check the coolant strength. For recommended coolant change intervals, refer to the engine manual.

8 Engine oil level (B)

⚠ WARNING

Burn hazard. Do not touch hot engine components without the correct PPE. Let the engine cool before you do an inspection or servicing. If you do not obey, there is a risk of death or serious injury.

- Use the dipstick to check the oil level.
- The oil level must be between the marks L (low) and H (high). Add oil if it is necessary. Refer to [2.13 Fluids](#).

B - Frequent Inspection

- For recommended oil change intervals, refer to the engine manual.

9 Air filter (B,C)

- Make sure there are no loose or missing parts.
- Make sure there is no visible damage.
- Squeeze the lips of the vacuator valve to remove the dirt and dust.
- Do an inspection of the service indicator on the air cleaner. Replace the filter element if necessary.

B - Frequent Inspection

- For the engine air filter maintenance procedure, refer to the engine manual.

C - Annual Inspection

- For the engine air filter replacement procedure, refer to the engine manual.

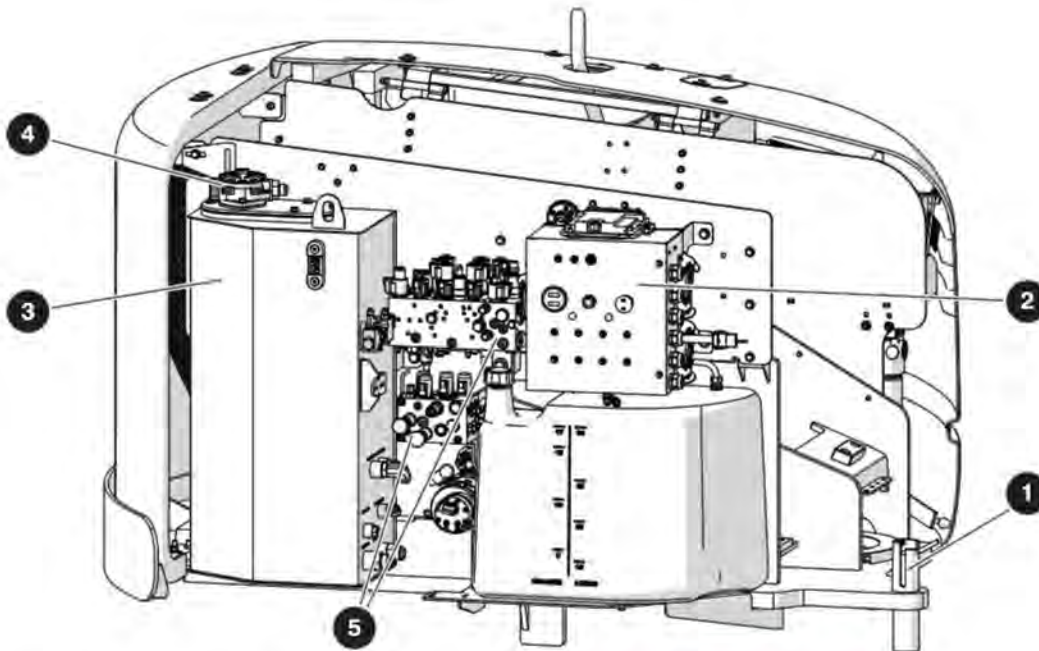

1.6-6 Control Compartment

Do the inspection that follows:

Make sure all compartment latches are latched tightly and in good condition.

1 Turret transportation lock (B)

- Make sure the turret transportation lock is unlocked.
- Make sure there are no loose or missing parts.
- Make sure there is no visible damage

2 Base Control Console (B)

- Make sure there are no loose or missing parts.
- Make sure there is no visible damage, and all the switches are in their off/neutral positions.

3 Hydraulic Tank (B)

- Make sure the hydraulic filler cap closes tightly.
- Make sure there is no visible damage or hydraulic leaks.

Hydraulic Oil (B, C)

- Make sure the boom is in the stowed position.
- Do a check on the **gauge** on the side of the hydraulic oil tank. The hydraulic oil level must be at or a small distance above the top mark of the gauge. Add oil if it is necessary. Refer to [2.13 Fluids](#).

C - Annual Inspection

- For the hydraulic oil replacement procedure, refer to [5.6-1 Hydraulic Oil Replacement](#).

4 Hydraulic Return Filter (B,C)

- Make sure the filter element is attached and tight.
- Make sure there is no visible damage or hydraulic leaks.

C - Annual Inspection

- For the hydraulic tank filter replacement procedure, refer to [5.6-2 Hydraulic Filter Replacement](#).

5 Manifolds (B)

- Make sure all fittings and hoses are correctly tightened.
- Make sure there is no indication of hydraulic leakage.
- Make sure there are no loose wires or missing fasteners.

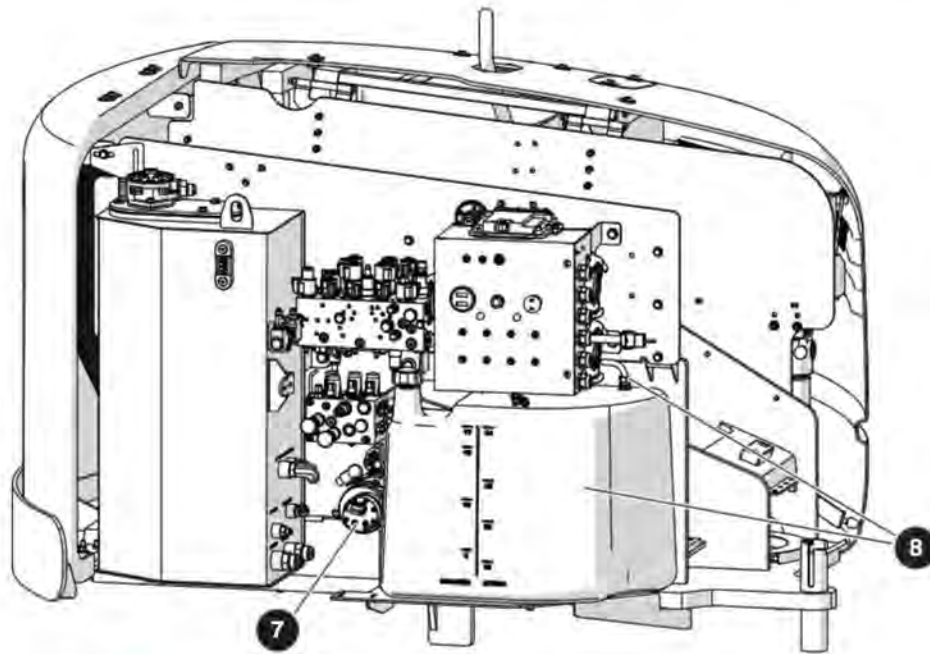

7 Emergency Power Unit (B)

- Make sure there are no loose or missing parts.
- Make sure there are no loose wires or missing fasteners.
- Make sure there is no visible damage.
- Make sure all the fittings and hoses are correctly tightened and there are no hydraulic leaks.

8 Fuel Tank and Lines (B)

IMPORTANT

Before you use the MEWP, make sure there is sufficient fuel for the estimated task.

DANGER

Explosion or fire hazard. Do not smoke near the fuel system. If you do not obey, there is a risk of death or serious injury.

- Make sure that the fuel filler cap closes tightly.
- Make sure there is no visible damage to the tank, gauge, hoses, or fittings.
- Make sure there is no indication of fuel leakage from the tank, gauge, hoses, fittings, pump, and filter.

WARNING

Environmental hazard. Immediately remove gasoline, diesel fuel, engine oil, and hydraulic fluid spills and leaks with rags. Discard these rags in accordance with national, state/provincial/territorial, and local regulations. Spilled fluids can damage the environment. When spilled fluids go into the water (for example, a sewage system, streams, rivers, or other surface water), they can kill aquatic life.

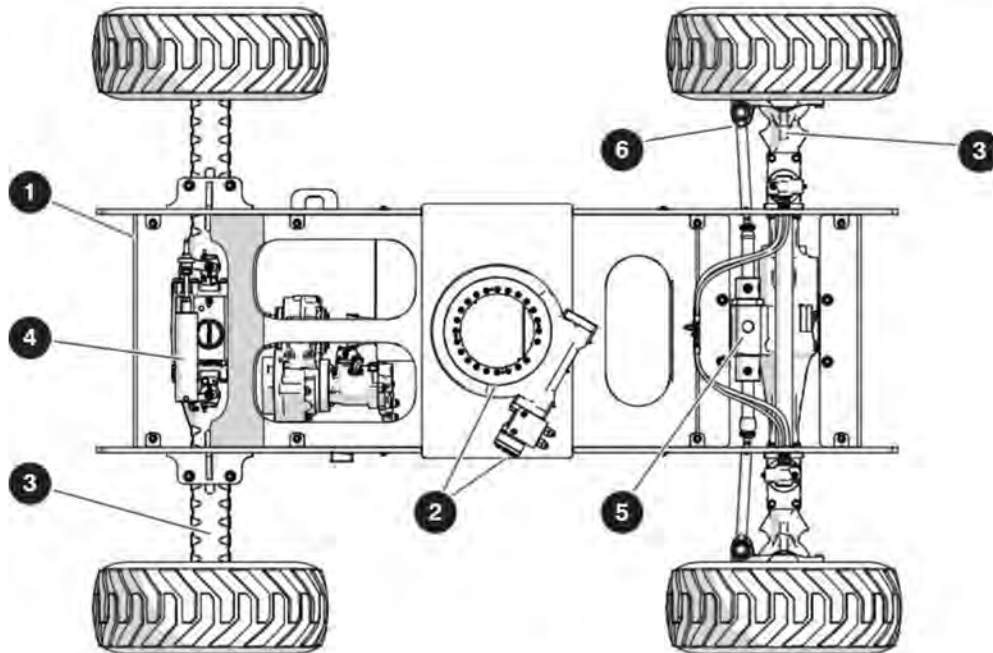

1.6-7 Base

1 Base weldment (B)

- Make sure there are no visible cracks in welds or structure and there are no signs of deformation.

2 Turret rotation motor and gear (B,C)

- Make sure there are no loose or missing parts.
- Make sure there is no visible damage.

C - Annual Inspection

- For the lube procedure, refer

3 Axles (B,C)

- Make sure the front and rear axles are correctly attached.
- Make sure there are no loose or missing parts.
- Make sure all the fittings and hose connections are tight.
- Make sure there is no sign of hydraulic leakage.

C - Annual Inspection

- Check the brakes annually. Refer to the procedure [5.8-11 Brake Inspection](#).

4 Brake Cylinder (B)

- Make sure there are no loose or missing parts.
- Make sure all the fittings and hoses are correctly tightened and there are no hydraulic leaks.

5 Steer cylinder (B)

- Make sure there are no loose or missing parts.
- Make sure all the fittings and hoses are correctly tightened and there are no hydraulic leaks.

6 Steer linkage (B)

- Make sure there are no loose or missing parts.
- Make sure the tie rod end studs are locked and there is no visible damage.

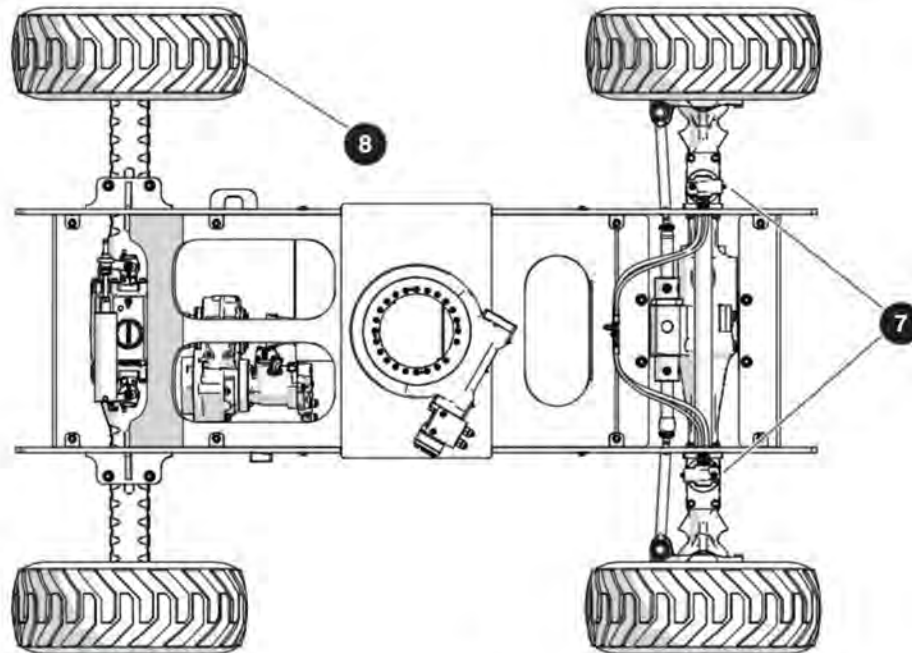

7 Oscillating cylinders (B,C)

- Make sure the oscillating cylinders are correctly attached, and there are no visible spaces.
- Make sure there are no loose or missing parts.
- Make sure all the fittings and hose connections are tight.
- Make sure there is no sign of hydraulic leakage.
- Do a check of the heads of the oscillating cylinder mounting bolts to make sure the torque seal is visible and undamaged. If the torque seal is damaged or is missing, remove and replace the affected bolts. Refer to [5.8-6 Oscillating Cylinder Bolt Replacement](#).



NOTE

The oscillating axle is locked when the MEWP is in the elevated travel position or at the elevated travel speed. Refer to [2.17 Axle Oscillation Diagram](#).

8 Wheel/tires (B,C)

- Do a check on all tire treads and sidewalls for cuts, cracks, holes, and unusual wear.
- Do a check on each wheel for damage, and cracked welds.
- Do a check on each lug nut for the correct torque to make sure they are not loose.
- Make sure the wheels are correctly aligned vertically and horizontally.
- Make sure there are no loose or missing parts.
- Make sure there is no visible damage.

B - Frequent Inspection

- For proper torque information, refer to [2.5 MEWP Torque Specifications](#).

⚠ WARNING

Do not use tires other than the tires that Skyjack specifies for this MEWP. Do not mix different types of tires or use tires that are not in good condition. Only replace the tires with the same types that are approved by Skyjack. The use of other tires can make the MEWP less stable. If you do not obey, there is a risk of death or serious injury.

Refer to [2.8 Tire Specifications](#).

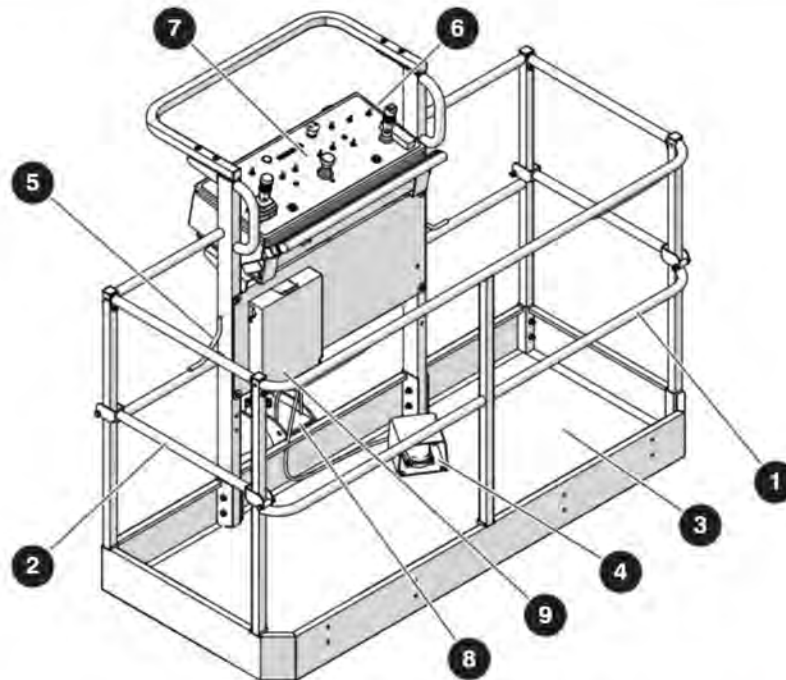

1.6-8 Platform

1 2 Railings and gates

- Make sure there are no loose or missing parts, and there is no visible damage.
- Make sure the fasteners are correctly installed.
- Make sure the platform railings 1 are in the correct position.
- Make sure the gates or drop bars 2 are in good condition and operate correctly.

3 MEWP floor

- Make sure the MEWP floor is solid and there is no visible damage.

4 Footswitch

- Make sure the footswitch is in good working order and has not been tampered with, disabled or blocked.

5 Fall-protection anchorages

- Make sure that the fall-protection anchorages are correctly installed.
- Make sure there is no visible damage.

6 AC power socket

- Make sure that the socket is free of dirt or blockages.

7 Platform control console (B)

- Make sure all switches and controllers are in the neutral position.
- Make sure there are no loose or missing parts, and there is no visible damage.

8 Manual storage box (B)

- Make sure that the operation manual and other important documents are in the manual storage box.
- Make sure that the documents are in good condition, and you can read them.
- Always put the manuals and other documents back in the storage box after use.

9 Load Cell - CE & AS (B)

- Make sure there are no loose or missing parts, and there is no visible damage.
- Make sure the fasteners are correctly installed.
- Make sure the cables are in good condition.
- Make sure the cable connections are tight.
- Make sure there is no debris lodged between the platform and the boom adaptor.

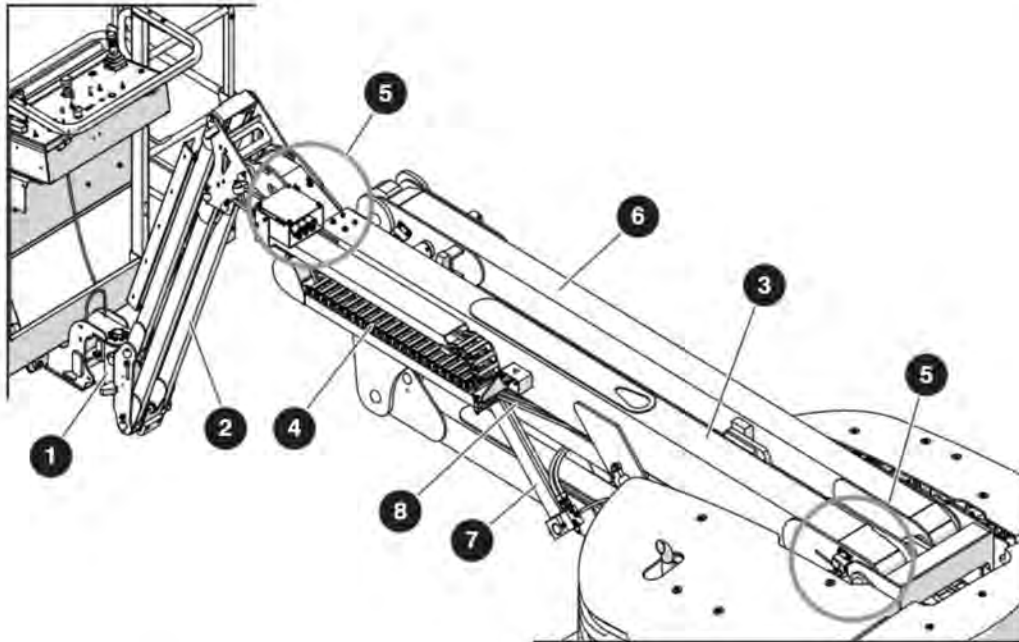

1.6-9 Boom Assembly

1 Rotary actuator

- There are no loose or missing parts, and there is no visible damage.
- All fasteners are correctly tightened.
- All hoses are correctly tightened and there is no sign of hydraulic leakage.

2 Jib (B)

- There are no loose or missing parts, and there is no visible damage.
- All fasteners are correctly tightened.
- All hoses are correctly tightened and there is no sign of hydraulic leakage.

3 Boom (B)

- There are no loose or missing parts, and there is no visible damage.
- All fasteners are correctly tightened.
- All hoses are correctly tightened and there is no sign of hydraulic leakage.
- Make sure there are no visible cracks in welds or structure and there are no signs of deformation.

4 Cable Track (B)

- There are no loose or missing parts, and there is no visible damage.

5 Wear Pads (B)

- All fasteners are correctly tightened.
- There are no loose or missing parts, and there is no visible damage to the wear pads.

6 Riser (B)

- There are no loose or missing parts.
- There is no visible damage.
- All fasteners and pins are correctly tightened.
- There are no visible cracks in welds or structure and there are no signs of deformation.

7 Cylinders (B)

- Make sure the cylinders are correctly installed.
- Make sure there is no indication of leaks or damage.
- Make sure all pins and bushings are secure and properly tightened.

8 Control Cables and Hoses (B)

- There are no loose or missing parts, and there is no visible damage.
- All hoses are correctly tightened and there is no sign of hydraulic leakage.

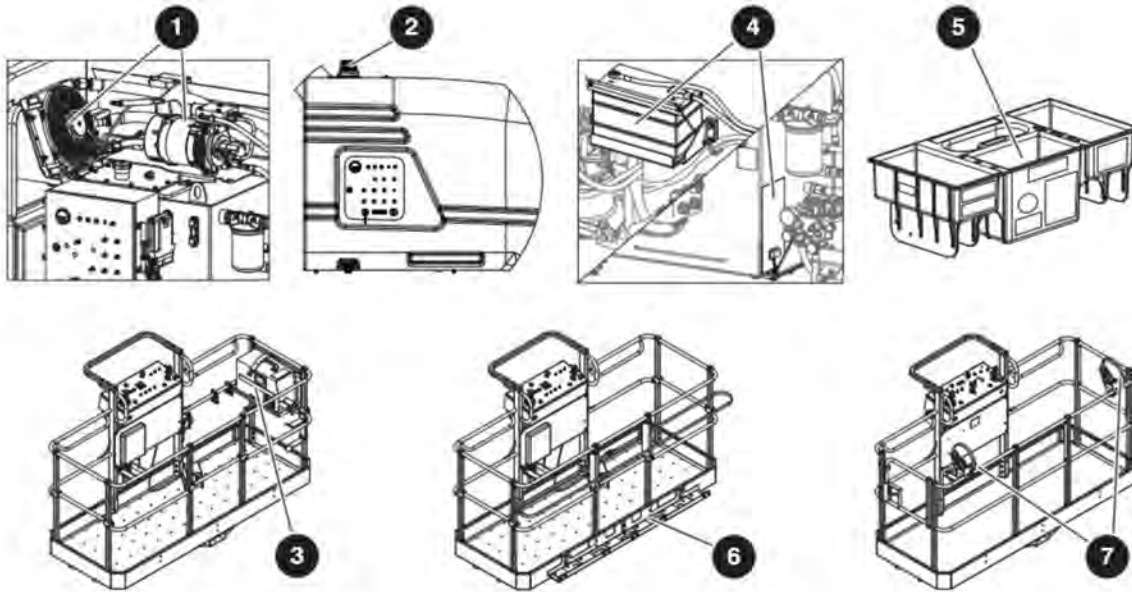

1.6-10 Optional equipment (B)

Do the inspection that follows, and make sure:

1 Generator

- There are no loose or missing parts, and there is no visible damage.
- All hoses are correctly tightened and there is no sign of hydraulic leakage.

2 Flashing amber light

- The lamp is correctly attached, and there is no visible damage.

3 Welder

- The welder and the welder tray are correctly attached.
- There are no loose or missing parts, and there is no visible damage.
- There are no loose wires or missing fasteners.

4 Cold or arctic weather package

- The heater plugs are correctly attached with no visible damage.
- There is no sign of engine oil leakage.

5 Tool tray

- The tray is correctly attached with lock-pins, and there is no visible damage.

6 Glazier

- There are no loose or missing parts, and there is no visible damage.

7 Pipe rack

- There are no loose or missing parts, and there is no visible damage.

1.7 Function Tests

Function tests are designed to discover any malfunctions before a MEWP is put into service. The operator must understand and follow step-by-step instructions to test all MEWP functions.

IMPORTANT

Never use a malfunctioning MEWP. If malfunctions are discovered, the MEWP must be tagged and placed out of service. Repairs to the MEWP may only be made by a qualified service technician.

- After repairs are completed, the operator must perform a pre-operation inspection and a series of function tests again before putting the MEWP into service.
- Prior to performing function tests, be sure to read and understand the “Start Operation” section of the operating manual.
- For function tests that are to be performed, please refer to the operating manual that corresponds to the correct serial number. Found there are detailed instructions for which tests to perform, as well as how to properly and successfully perform them.



NOTE

The all-function motion alarm should sound while operating any boom and drive function.

Section 2 – Maintenance Tables and Diagrams

2.1 Standard Hose Numbering System

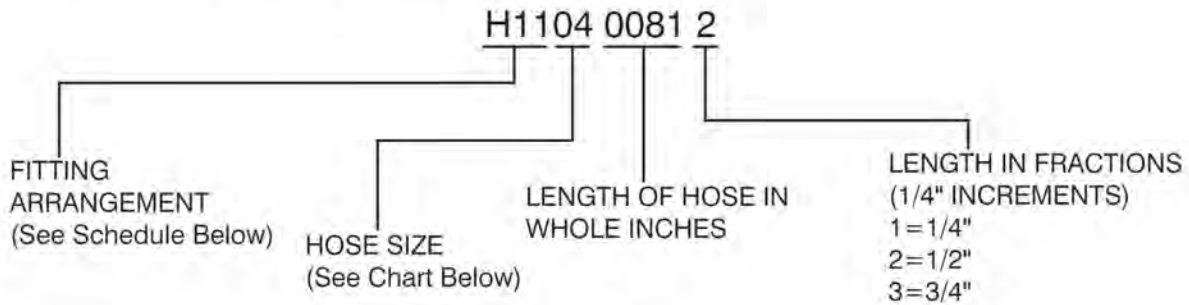

Using the number above as an example, H1104 0081 2, this hose requires a 37° JIC female swivel fitting on one end, and a medium length 90° JIC female swivel fitting for the other end. The hose must meet or exceed the S.A.E. 100R13 hose specification, and be a total of 81-1/2" long.



NOTE

Hose ends and hose must be from same manufacturer per S.A.E. J1273 Nov. '91, Sections 3.10 and 4.2. Hose ends and hose must be of the same size i.e. #4 size fittings must be used with #4 size hose.

Hose Size Chart														
Size	03	04	06	08	10	12	16	20	24	32	40	48	56	64
ID	3/16"	1/4"	3/8"	1/2"	5/8"	3/4"	1"	1-1/4"	1-1/2"	2"	2-1/2"	3"	3-1/2"	4"

Fitting Arrangement Schedule			
Hose Prefix	Hose End Fitting	Hose End Fitting	S.A.E. Hose Specification
H01	FEMALE, 37° JIC, SWIVEL	FEMALE, 37° JIC, SWIVEL	100R17
H02	FEMALE, 37° JIC, SWIVEL	FEMALE, 37° JIC, SWIVEL	100R13
H03	FEMALE, 37° JIC, SWIVEL	45°, FEMALE, 37° JIC, SWIVEL	100R17
H04	FEMALE, 37° JIC, SWIVEL	45°, FEMALE, 37° JIC, SWIVEL	100R13
H05	FEMALE, 37° JIC, SWIVEL	LONG 90°, FEMALE, 37° JIC, SWIVEL	100R17
H06	FEMALE, 37° JIC, SWIVEL	SHORT 90°, FEMALE, 37° JIC, SWIVEL	100R17
H07	LONG 90°, FEMALE, 37° JIC, SWIVEL	LONG 90°, FEMALE, 37° JIC, SWIVEL	100R17
H08	FEMALE, 37° JIC, SWIVEL	FEMALE, 37° JIC, SWIVEL	100R4
H09	FEMALE, 37° JIC, SWIVEL	45°, FEMALE, 37° JIC, SWIVEL	100R4
H10	FEMALE, 37° JIC, SWIVEL	MALE PIPE THREAD FITTING	100R17
H11	FEMALE, 37° JIC, SWIVEL	MEDIUM 90°, FEMALE, 37° JIC, SWIVEL	100R13
H12	SHORT 90°, FEMALE, 37° JIC, SWIVEL	SHORT 90°, FEMALE, 37° JIC, SWIVEL	100R17
H13	FEMALE, 37° JIC, SWIVEL	REUSABLE MALE PIPE THREAD FITTING	300 PSI
H14	REUSABLE MALE PIPE THREAD FITTING	NO FITTING	300 PSI

Hose Prefix	Hose End Fitting	Hose End Fitting	S.A.E. Hose Specification
H15	REUSABLE FEMALE, 37° JIC, SWIVEL	REUSABLE FEMALE, 37° JIC, SWIVEL	300 PSI
H16	NO FITTING	NO FITTING	100R4
H17	NO FITTING	NO FITTING	300 PSI
H18	REUSABLE, FEMALE, 37° JIC, SWIVEL	NO FITTING	300 PSI
H19	LONG 90°, FEMALE, 37° JIC, SWIVEL	FEMALE, 37° JIC, SWIVEL	100R13
H20	FEMALE, SHORT 37° JIC, SWIVEL	SHORT 90°, FEMALE, 37° JIC, SWIVEL	100R4
H21	FEMALE, SHORT 37° JIC, SWIVEL	SHORT 90°, FEMALE, 37° JIC, SWIVEL	100R2AT
H22	FEMALE, 37° JIC, SWIVEL	FEMALE, 37° JIC, SWIVEL	100R2AT
H23	FEMALE, LONG 37° JIC, SWIVEL	LONG 90°, FEMALE, 37° JIC, SWIVEL	100R2AT
H24	FEMALE, SHORT 37° JIC, SWIVEL	SHORT 90°, FEMALE, 37° JIC, SWIVEL	100R13
H25	FEMALE, 37° JIC, SWIVEL	FEMALE, 37° JIC, SWIVEL	100R4
H30	MEDIUM 90°, FEMALE, 37° JIC, SWIVEL	FEMALE, 37° JIC, SWIVEL	100R17
H31	FEMALE, 37° JIC, SWIVEL	FEMALE, 37° JIC, SWIVEL	100R17
H32	SHORT 45°, FEMALE, 37° JIC, SWIVEL	FEMALE, 37° JIC, SWIVEL	100R17
H33	MEDIUM 45°, FEMALE, 37° JIC, SWIVEL	FEMALE, 37° JIC, SWIVEL	100R17
H34	SHORT 90°, FEMALE, 37° JIC, SWIVEL	FEMALE, 37° JIC, SWIVEL	100R17
H35	MEDIUM 90°, FEMALE, 37° JIC, SWIVEL	FEMALE, 37° JIC, SWIVEL	100R17
H36	LONG 90°, FEMALE, 37° JIC, SWIVEL	FEMALE, 37° JIC, SWIVEL	100R17
H37	SHORT 45°, FEMALE, 37° JIC, SWIVEL	FEMALE, 37° JIC, SWIVEL	100R4
H38	SHORT 90°, FEMALE, 37° JIC, SWIVEL	FEMALE, 37° JIC, SWIVEL	100R4
H39	LONG 90°, FEMALE, 37° JIC, SWIVEL	FEMALE, 37° JIC, SWIVEL	100R4
H40	SHORT 90°, FEMALE, 37° JIC, SWIVEL	FEMALE, 37° JIC, SWIVEL	100R16
H43	FEMALE, 37° JIC, SWIVEL	FEMALE, 37° JIC, SWIVEL	100R16
H51	FEMALE, 37° JIC, SWIVEL	FEMALE, 37° JIC, SWIVEL	100R17
H52	SHORT 45°, FEMALE, 37° JIC, SWIVEL	FEMALE, 37° JIC, SWIVEL	100R17
H53	MEDIUM 45°, FEMALE, 37° JIC, SWIVEL	FEMALE, 37° JIC, SWIVEL	100R17
H54	SHORT 90°, FEMALE, 37° JIC, SWIVEL	FEMALE, 37° JIC, SWIVEL	100R17
H55	MEDIUM 90°, FEMALE, 37° JIC, SWIVEL	FEMALE, 37° JIC, SWIVEL	100R17
H56	LONG 90°, FEMALE, 37° JIC, SWIVEL	FEMALE, 37° JIC, SWIVEL	100R17
H57	SHORT 45°, FEMALE, SAE ORFS, SWIVEL	FEMALE, SAE ORFS, SWIVEL	100R13
H58	FEMALE, SAE ORFS, SWIVEL	FEMALE, SAE ORFS, SWIVEL	100R13
H59	MEDIUM 90°, FEMALE, SAE ORFS, SWIVEL	FEMALE, SAE ORFS, SWIVEL	100R13
H60	FEMALE, 37° JIC, SWIVEL	FEMALE, 37° JIC, SWIVEL	100R17
H61	FEMALE, 37° JIC, SWIVEL	FEMALE, 37° JIC, SWIVEL	100R16
H62	SHORT 90°, FEMALE, 37° JIC, SWIVEL	FEMALE, 37° JIC, SWIVEL	100R16
H63	MEDIUM 90°, FEMALE, 37° JIC, SWIVEL	FEMALE, 37° JIC, SWIVEL	100R16
H64	LONG 90°, FEMALE, 37° JIC, SWIVEL	FEMALE, 37° JIC, SWIVEL	100R16
H65	MEDIUM 67°, FEMALE, 37° JIC, SWIVEL	FEMALE, 37° JIC, SWIVEL	100R12
H66	FEMALE, 37° JIC, SWIVEL	NO FITTING	100R4
H67	FEMALE, 37° JIC, SWIVEL	FEMALE, 37° JIC, SWIVEL	100R19
H68	SHORT 45°, FEMALE, 37° JIC, SWIVEL	FEMALE, 37° JIC, SWIVEL	100R19
H69	MEDIUM 90°, FEMALE, 37° JIC, SWIVEL	FEMALE, 37° JIC, SWIVEL	100R19
H70	LONG 90°, FEMALE, 37° JIC, SWIVEL	FEMALE, 37° JIC, SWIVEL	100R19
H71	LONG 90°, FEMALE, SAE ORFS, SWIVEL	FEMALE, SAE ORFS, SWIVEL	100R15

2.2 Torque Specifications for Fasteners (US Imperial)

Size	Torque Type	SAE2		SAE 5		SAE 8	
		Dry	Lubed	Dry	Lubed	Dry	Lubed
4-40	(in-lb)	(5)	(4)	(8)	(6)	(12)	(9)
	Nm	0.6	0.5	0.9	0.7	1.4	1.0
4-48	(in-lb)	(6)	(5)	(9)	(7)	(13)	(10)
	Nm	0.7	0.6	1.0	0.8	1.5	1.1
6-32	(in-lb)	(10)	(8)	(16)	(12)	(23)	(17)
	Nm	1.1	0.9	1.8	1.4	2.6	1.9
6-40	(in-lb)	(12)	(9)	(18)	(13)	(25)	(19)
	Nm	1.4	1.0	2.0	1.5	2.8	2.1
8-32	(in-lb)	(19)	(14)	(30)	(22)	(41)	(31)
	Nm	2.1	1.6	3.4	2.5	4.6	3.5
8-36	(in-lb)	(20)	(15)	(31)	(23)	(43)	(32)
	Nm	2.3	1.7	3.5	2.6	4.9	3.6
10-24	(in-lb)	(27)	(21)	(43)	(32)	(60)	(45)
	Nm	3.1	2.4	4.9	3.6	6.8	5.1
10-32	(in-lb)	(31)	(23)	(49)	(36)	(68)	(51)
	Nm	3.5	2.6	5.5	4.1	7.7	5.8
1/4-20	(in-lb) ft-lb	(66)	(50)	8	(75)	12	9
	Nm	7.5	5.6	11	8.5	16	12
1/4-28	(in-lb) ft-lb	(76)	(56)	10	(86)	14	10
	Nm	8.6	6.3	14	9.7	19	14
5/16-18	ft-lb	11	8	17	13	25	18
	Nm	15	11	23	18	34	24
5/16-24	ft-lb	12	9	19	14	25	20
	Nm	16	12	26	19	34	27
3/8-16	ft-lb	20	15	30	23	45	35
	Nm	27	20	41	31	61	47
3/8-24	ft-lb	23	17	35	25	50	35
	Nm	31	23	47	34	68	47
7/16-14	ft-lb	32	24	50	35	70	55
	Nm	43	33	68	47	95	75
7/16-20	ft-lb	36	27	55	40	80	60
	Nm	49	37	75	54	108	81
1/2-13	ft-lb	50	35	75	55	110	80
	Nm	68	47	102	75	149	108
1/2-20	ft-lb	55	40	90	65	120	90
	Nm	75	54	122	88	163	122

Size	Torque Type	SAE2		SAE 5		SAE 8	
		Dry	Lubed	Dry	Lubed	Dry	Lubed
9/16-12	ft-lb	70	55	110	80	150	110
	Nm	95	75	149	108	203	149
9/16-18	ft-lb	80	60	120	90	170	130
	Nm	108	81	163	122	230	176
5/8-11	ft-lb	100	75	150	110	220	170
	Nm	136	102	203	149	298	230
5/8-18	ft-lb	110	85	180	130	240	180
	Nm	149	115	244	176	325	244
3/4-10	ft-lb	175	130	260	200	380	280
	Nm	237	176	353	271	515	380
3/4-16	ft-lb	200	150	300	220	420	320
	Nm	271	203	407	298	569	434
7/8-9	ft-lb	170	125	430	320	600	460
	Nm	230	169	583	434	813	624
7/8-14	ft-lb	180	140	470	360	660	500
	Nm	244	190	637	488	895	678
1-8	ft-lb	250	190	640	480	900	680
	Nm	339	258	868	651	1220	922
1-12	ft-lb	270	210	710	530	1000	740
	Nm	366	285	963	719	1356	1003
1-14	ft-lb	280	210	730	540	1020	760
	Nm	380	285	990	732	1383	1030
1 1/8-7	ft-lb	350	270	800	600	1280	960
	Nm	475	366	1085	813	1735	1302
1 1/8-12	ft-lb	400	300	880	660	1440	1080
	Nm	542	407	1193	895	1952	1464
1 1/4-7	ft-lb	500	380	1120	840	1820	1360
	Nm	678	515	1519	1139	2468	1844
1 1/4-12	ft-lb	550	420	1240	920	2000	1500
	Nm	746	569	1681	1247	2712	2034
1 3/8-6	ft-lb	670	490	1460	1100	2380	1780
	Nm	908	664	1979	1491	3227	2413
1 3/8-12	ft-lb	750	560	1680	1260	2720	2040
	Nm	1017	759	2278	1708	3688	2766
1 1/2-6	ft-lb	870	650	1940	1460	3160	2360
	Nm	1180	881	2630	1979	4284	3200
1 1/2-12	ft-lb	980	730	2200	1640	3560	2660
	Nm	1329	990	2983	2224	4827	3606

NOTE: Lubed includes lubricants such as lubrizing, oil, grease, or uncured Loctite.

1374AA

2.3 Torque Specifications for Fasteners (Metric)

Size	Torque Type	8.8		10.9	
		Dry	Lubed	Dry	Lubed
M5 x 0.80	(in-lb)	(54)	(41)	(78)	(59)
	Nm	6.1	4.6	8.8	6.7
M6 x 1.00	(in-lb)	(92)	(69)	(133)	(99)
	Nm	10.4	7.8	15	11.2
M7 x 1.00	(in-lb)	(156)	(116)	(222)	(167)
	Nm	17.6	13.1	25.1	18.9
M8 x 1.25	(in-lb)	(225)	(169)	(333)	(242)
	Nm	25.4	19.1	37.6	27.3
M10 x 1.50	ft-lb	37	28	53	40
	Nm	50	38	72	54
M12 x 1.75	ft-lb	65	49	93	69
	Nm	88	66	126	94
M14 x 2.00	ft-lb	104	78	148	111
	Nm	141	106	201	150
M16 x 2.00	ft-lb	161	121	230	172
	Nm	218	164	312	233
M18 x 2.50	ft-lb	222	167	318	238
	Nm	301	226	431	323
M20 x 2.50	ft-lb	314	235	449	337
	Nm	426	319	609	457
M22 x 2.50	ft-lb	428	321	613	460
	Nm	580	435	831	624
M24 x 3.00	ft-lb	543	407	776	582
	Nm	736	552	1052	789
M27 x 3.00	ft-lb	796	597	1139	854
	Nm	1079	809	1544	1158
M30 x 3.50	ft-lb	1079	809	1543	1158
	Nm	1463	1097	2092	1570
M33 x 3.50	ft-lb	1468	1101	2101	1576
	Nm	1990	1493	2849	2137
M36 x 4.00	ft-lb	1886	1415	2699	2024
	Nm	2557	1918	3659	2744

NOTE: Lubed includes lubricants such as lubrizing, oil, grease, or uncured Loctite.

1375AB

2.4 Torque Specifications for Hydraulic Couplings & Hoses

Hydraulic Coupling Torque Chart O-Ring Port Connectors				
SAE Size	Steel Ports		Non-ferrous Ports	
	ft-lb	Nm	ft-lb	Nm
4	14-16	20-22	9-10	12-13
6	24-26	33-35	15-16	20-21
8	50-60	68-78	30-36	41-47
10	72-80	98-110	43-48	60-66
12	125-135	170-183	75-81	102-110
16	200-220	270-300	120-132	162-180
20	210-280	285-380	126-168	171-228
24	270-360	370-490	162-216	222-294
32	-	-	-	-

Hose End Torque Chart for JIC									
Size		Steel				Brass			
Dash	Frac.	ft-lb		Nm		ft-lb		Nm	
		Min.	Max.	Min.	Max.	Min.	Max.	Min.	Max.
-4	1/4"	10	11	13	15	5	6	6.75	9
-6	3/8"	17	19	23	26	12	15	17	20
-8	1/2"	34	38	47	52	20	24	27.66	33
-10	5/8"	50	56	69	76	34	40	46.33	55
-12	3/4"	70	78	96	106	53	60	72.33	82
-16	1"	94	104	127	141	74	82	100.5	111
-20	1 1/4"	124	138	169	188	75	83	101.5	113
-24	1 1/2"	156	173	212	235	79	87	107	118
-32	2"	219	243	296	329	158	175	214	237

Hose End Torque Chart for Flat-Face O-Ring Seal (Steel)					
Size		Torque Specification			
Dash	Frac.	ft-lb		Nm	
		Min.	Max.	Min.	Max.
-4	1/4"	10	12	14	16
-6	3/8"	18	20	24	27
-8	1/2"	32	40	43	54
-10	5/8"	46	56	60	75
-12	3/4"	65	80	90	110
-14	1"	65	80	90	110
-16	1 1/4"	92	105	125	240
-20	1 1/2"	125	140	170	190
-24	2"	150	180	200	245

1276AA

2.5 MEWP Torque Specifications

Location	Description	Torque (ft-lb)	Torque (Nm)
Base			
Trunnion Mount	BOLT, Hex head (3/4"-10 x 5", Grade 8)	210	285
Rear Axle Mount	NUT, Torque lock (3/4"-10, Grade C)	210	285
Axle Lock	BOLT, Hex head (1/2"-13 x 2.25", Grade 8)	80	108
Swing Drive Motor	SCREW, Socket head cap (3/4"-10 x 2.25")	280	380
Rotation Gear	BOLT, Hex head (5/8"-11 x 4.5", Grade 8)	170	230
Hydraulic Drive Motor	BOLT, Hex head (M14 x 2 x 30mm, ZP, Grade 8.8)	80	108
Wheel Nut	NUT, Wheel	247-302	335-410
Turret			
Rotation Gear	BOLT, Hex head (5/8"-11 x 2.75", Grade 8)	170	230
Engine			
Deutz Engine Mount	BOLT, Hex head (1/2"-13 x 3.75", Grade 5)	55	75
Coupling Assembly (Deutz)	BOLT (M10)	40	55
	COUPLING CLAMP BOLT	45	61
GM Engine Mount	NUT, Hex head (1/2"-13, Grade 5)	50	68
Drive Pump	BOLT, Hex head (1/2"-13 x 1.5", Grade 5)	55	75
System Pump	BOLT, Socket (3/8"-16 x 1, Grade 5)	23	31
Cylinders			
Lift	ROD NUT	425	576
	GLAND	400	542
Extension	ROD NUT (SJ46A / SJ51AJ)	300	407
	ROD NUT (SJ46AJ)	150	203
Master	GLAND	450-500	610-678
	ROD NUT	350	475
Slave	GLAND & ROD NUT	350	475
Axle Lock	GLAND	350	475
	BOLT, Hex head (1/2"-13 x 2.25", Grade 8)	80	108
Jib	BOLT, Hex head (0.312-18 x 2.75", Grade 5 \ ZP)	15	20
Riser	ROD NUT & GLAND	350	475
Platform			
Rotary Mount	BOLT, Hex head, patch (3/8"-16 x 7/8", Grade 8 \ ZP)	35	48
	BOLT, Hex head (1"-8 x 10.5", zinc, Grade 8)	480	569
Rotary Actuator	BOLT, Hex head (3/4"-10 x 3", Grade 8)	210	285
Load Cell Mounting (CE)	BOLT, Hex head patch (M16 x 1.5 x 4.5, Grade 8.8 \ ZP)	130	177
	BOLT, Hex head (1/2"-13 x 2.5", Grade 8)	80	108

1402AB

2.6 Axle Torque Specifications

Size of Bolt		Type of Bolt					
		8.8		10.9		12.9	
		Normali Loctite 242 (Nm)	Loctite 270 (Nm)	Normali Loctite 242 (Nm)	Loctite 270 (Nm)	Normali Loctite 242 (Nm)	Loctite 270 (Nm)
Coarse Pitch	M6 x 1	9.5-10.5	10.5-11.5	14.3-15.7	15.2-16.8	16.2-17.8	18.1-20.0
	M8 x 1.25	23.8-26.2	25.6-28.4	34.2-37.8	36.7-40.5	39.0-43.0	43.7-48.3
	M10 x 1.5	48-53	52-58	68-75	73-81	80-88	88-97
	M12 x 1.75	82-91	90-100	116-128	126-139	139-153	152-168
	M14 x 2	129-143	143-158	182-202	200-221	221-244	238-263
	M16 x 2	200-221	219-242	283-312	309-341	337-373	371-410
	M18 x 2.5	276-305	299-331	390-431	428-473	466-515	509-562
	M20 x 2.5	390-431	428-473	553-611	603-667	660-730	722-798
	M22 x 2.5	523-578	575-635	746-824	817-903	893-987	974-1076
	M24 x 3	675-746	732-809	950-1050	1040-1150	1140-1260	1240-1370
	M27 x 3	998-1103	1088-1202	1411-1559	1539-1701	1710-1890	1838-2032
M30 x 3.5	1378-1523	1473-1628	1914-2115	2085-2305	2280-2520	2494-2757	
Fine Pitch	M8 x 1	25.7-28.3	27.5-30.5	36.2-39.8	40.0-44.0	42.8-47.2	47.5-52.5
	M10 x 1.25	49.4-54.6	55.2-61.0	71.5-78.5	78.0-86.0	86.0-94.0	93.0-103.0
	M12 x 1.25	90-100	98-109	128-142	139-154	152-168	166-184
	M12 x 1.5	86-95	94-104	120-132	133-147	143-158	159-175
	M14 x 1.5	143-158	157-173	200-222	219-242	238-263	261-289
	M16 x 1.5	214-236	233-257	302-334	333-368	361-399	394-436
	M18 x 1.5	312-345	342-378	442-489	485-536	527-583	580-641
	M20 x 1.5	437-483	475-525	613-677	674-745	736-814	808-893
	M22 x 1.5	581-642	637-704	822-908	903-998	998-1103	1078-1191
	M24 x 2	741-819	808-893	1045-1155	1140-1260	1235-1365	1363-1507
	M27 x 2	1083-1197	1178-1302	1520-1680	1672-1848	1834-2027	2000-2210
M30 x 2	1511-1670	1648-1822	2138-2363	2332-2577	2565-2835	2788-3082	

1373AA

Note: 1 Nm = 0.7376 ft-lb

Screw-locking, Sealing and Lubricating Materials

Loctite 242

- Anaerobic product apt to prevent the loosening of screws, nuts and plugs. Used for medium-strength locking. Before using it, completely remove any lubricant by using the specific activator.

Loctite 270

- Anaerobic product apt to prevent the loosening of screws, nuts and plugs. Used for medium-strength locking. Before using it, completely remove any lubricant by using the specific activator. To remove parts, it may be necessary to heat them at 80°C approx.

2.7 Axle Maintenance Intervals

Operation	Component	Frequency	Lubricants
Check Levels	Differential	monthly	SAE 80W-90 API GL-5
	Planetary reduction	every 200 hours	
	Gear box	monthly	
Oil Change	Differential	every 800 hours *	SAE 80W-90 API GL-5
	Planetary reduction	every 1000 hours *	
	Self-locking differential gear	every 700 hours * &	
	Gear box	once at 50 hours after every 1000 hours	
Tighten	Gear box screws/bolts	every 200 hours	N/A
	Wheel Nuts	every 200 hours	

Operation	Member	Conditions	Frequency	Lubricants
Grease	Articulations	Normal work	monthly	MOLIKOTE
		Awkward work	weekly	

Torque Wrench Settings (Nm)			
Size of Screw	8G/8.8	10K/10.9	12K/12.9
M4	2.9	4.1	-
M6	10	14	-
M8	25	35	-
M12	49	69	-
M10 X 1.25	-	73	-
M12	86	120	-
M14	135	190	-
M14 X 1.5	-	-	250
M16	210	295	-
A18	325	-	-

*Initially after 100 working hours
& when it starts sounding noisy

1376AB



NOTE

1 Nm = 0.7376 ft-lb

2.8 Tire Specifications

Tire	Type	Size	Ply Rating	Wheel Nuts Torque
SJ45 AJ+	Solid	25.4 cm x 76.2 cm (10 in x 31 in)	~	393 Nm (290 ft-lb)

2147AA

WARNING

Do not use tires other than those specified for this machine. Do not mix different types of tires. Tires other than those specified can adversely affect stability. Failure to operate with matched, approved tires in good condition can result in death or serious injury. Replace tires with the exact, Skyjack-approved types only.

IMPORTANT

For the proper functioning of each axle differential, all four wheels must have same tire size installed at all times. Failure to comply with this requirement will reduce the life of the differentials and reduce the overall mobility of the MEWP.

2.9 Floor Loading Pressure

Model		Weights				Pressures			
		Gross MEWP Weight		Weight per Wheel**		LCP***		OFL***	
		kg	lb	kg	lb	kPa	psi	kPa	psf
SJ45 AJ+	min*	5075	11 190	1450	3200	766	111	7.6	160
	max*	5375	11 850	2725	6000	1026	149	8	168

2152AA

- * **Min:** Minimum MEWP weight (Unloaded platform, no options/attachments)
- Max:** Maximum MEWP weight (Platform loaded to capacity with options/attachments)

****Wheel Load** is the weight that can be experienced on one wheel.

Note: This is more than 25% of the machine weight due to possible weight distribution over the machine and platform.

*****LCP:** Local Concentrated Pressure is a measure of how hard the MEWP presses on the area in direct contact with the floor/tire.

OFL: Overall Floor Load (Pressure) is a measure of the average load the MEWP imparts on the whole surface directly underneath the chassis. This has been calculated by dividing the MEWP weight by the overall floor area occupied by the MEWP (on wheels).

The welder option adds approximately 158.8 kg (350 lb) to total MEWP weight and 79.4 kg (175 lb) to the max. wheel load.

Note: The floor covering (e.g., tile, carpet, etc.) or the structure (e.g., beams) of the operating surface must be able to withstand more than the values indicated above.

Note: The LCP or OFL that an individual surface can withstand varies from structure to structure and is generally determined by the engineer or architect for that particular structure.

Locally Concentrated Pressure (LCP)

Foot Print Area identified by test

$$LCP = \frac{\text{Wheel Load}}{\text{Foot Print Area}}$$

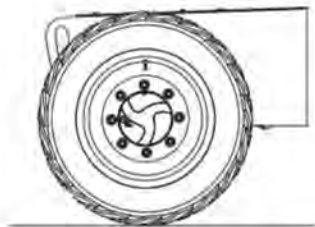

Foot Print Area

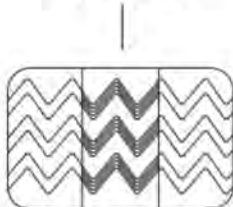

Overall Floor Load (OFL)

Base Area = Length x Width

$$OFL = \frac{\text{Weight of MEWP} + \text{Capacity}}{\text{Base Area}}$$

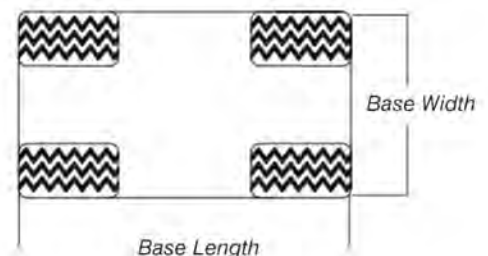

2.10 Hydraulic Specifications

Description		Metric	US
Pumps			
Drive Pump	Displacement - 2000 rpm	46 CC	2.8 CIR 24.3 gpm @ 2000 rpm
	Drive Pump Pressure	345 bar	5000 psi
	Charge Pump Displacement	13.9 CC	0.85 CIR
	Charge Pump Pressure	22 bar	313 psi
System Pump	Displacement - Static	11 CC	0.67 CIR / 5.8 gpm @ 2000 rpm
	System Pump Pressure	207 bar	3000 psi
Filters			
Charge Pump Filter	Max. Operating Pressure	9 μ m/35	50 psi
High Pressure Filter	Max. Operating Pressure	10 μ m/25	87 psi
Return Filter	Max. Operating Pressure	10 μ m/40	22 psi
Motors			
Drive Motor	Displacement - Low	21 CC	1.55 CIR
	Displacement - High	38 CC	2.32 CIR
Swing Motor	Motor Displacement	65.56 CC	4 CIR
	Maximum Swing Pressure	121 bar	1750 psi
Cylinders			
Extension Cylinder	Bore	5.1 cm	2 in.
	Rod Diameter	3.2 cm	1.25 in.
	Stroke	1.7 m	67 in.
	Maximum Boom Pressure	207 bar	3000 psi
Main Lift Cylinder	Bore	10.2 cm	4 in.
	Rod Diameter	4.5 cm	1.75 in.
	Stroke	64.6 cm	25.44 in.
	Maximum Lift Pressure	207 bar	3000 psi
Riser Cylinder	Bore	6.4 cm	2.5 in.
	Rod Diameter	4.5 cm	1.75 in.
	Stroke	92 cm	36.21 in.
	Maximum Lift Pressure	207 bar	3000 psi
	Maximum Lower Pressure	190 bar	2750 psi
Steering Cylinder	Maximum Steering Pressure	207 bar	3000 psi

2039AB

2.11 MEWP Specifications

Height & Reach	Working Height - maximum	15.54 m	51 ft 0 in
	Platform Height - maximum	13.72 m	45 ft 0 in
	Horizontal Reach - maximum	6.93 m	22 ft 9 in
	Horizontal Reach - at maximum height	2.98 m	9 ft 10 in
	Horizontal Reach - fly boom retracted	5.23 m	17 ft 2 in
	Tailswing	0.61 m	2 ft 0 in
	Up and Over Clearance - at platform	7.53 m	24 ft 8.75 in
	Up and Over Clearance - at main boom	7.45 m	24 ft 5.25 in
Platform	Platform Size	0.76 x 1.52 m	30 x 60 in
		0.76 x 1.83 m	30 x 72 in
	Platform Rotation	175°	
	Platform rotation radius	1.14 m	45 in
	Platform height - stowed	0.28 m	11 in
	Overall railing height	1.35 m	53 in
Jib	Jib Length	1.42 m	55.75 in
	Jib vertical Range of Motion	2.7 m	106.5 in
	Jib Range of Motion - down	70°	
	Jib Range of Motion - up	75°	
Dimensional Data	Height - stowed min.	2.06 m	6 ft 9 in
	Stowed length @ min. height	6 m	19 ft 8 in
	Stowed length - min.	4.75 m	15 ft 7 in
	Width	2.29 m	7 ft 6 in
	Wheelbase	2.03 m	6 ft 8 in
	Ground Clearance - chassis	0.39 m	15.25 in
	Ground Clearance - front axle	0.33 m	13 in
	Axle Oscillation	0.09 m	3.7 in
	Turning Radius - inside	1.5 m	4 ft 11.25 in
	Turning Radius - outside	4.34 m	14 ft 3 in
	Turret Rotation	360°	

2148AA

2.11 MEWP Specifications (continued)

Performance & Speeds	Gradeability - maximum	40%	
	Drive Speed - stowed / low torque	4 km/h	2.5 mph
	Drive Speed - stowed / high torque	1.9 km/h	1.2 mph
	Drive Speed - elevated / low torque	0.6 km/h	0.36 mph
	Drive Speed - elevated / high torque	0.6 km/h	0.36 mph
	Turret Rotation Time - stowed	70 - 90 s (ANSI/CSA & AS) 90 - 110 s (CE)	
	Platform Rotation Time	5 - 9 s	
	Boom Up Time	29 - 32 s	
	Boom Down Time	27 - 30 s	
	Boom Extend Time	10 - 16 s	
	Boom Retract Time	24 - 27 s	
	Riser Up	24 - 30 s	
	Riser Down	24 - 30 s	
	Jib Up Time	18 - 24 s	
	Jib Down Time	10 - 16 s	
Electrical	Steer Left Time	5 - 9 s	
	Steer Right Time	5 - 9 s	
	System Voltage	12 V DC	
	Battery Type	Lead / Acid	

2148AA-2

2.12 Platform Capacities

		Regular Platform Capacity		Derated Platform Capacity*	
	Capacity	300 kg	660 lb	272 kg	600 lb
	Maximum number of people	3	3	1	1
	Manual side force	400 N	90 lbf	200 N	45 lbf
Wind rating	-	12.5 m/s (28 mph)		12.5 m/s (28 mph)	
Tilt cutout setting	side-to-side x front-to-back	5 degrees x 5 degrees		5 degrees x 5 degrees	

2150AA

2.13 Fluids

Fluid	Temperature Range		Recommended Type
Hydraulic Oil	Standard / Cold	-26°C to 38°C (-15°F to 100°F)	Petro-Canada ATF D3M, Shell ATF Donax TG
	Biodegradable	-29°C to 32°C (-20°F to 90°F)	Shell Naturelle HF-E 46
	Arctic	-40°C to 38°C (-40°F to 100°F)	Esso Univis HVI 26
Gear Oil	Standard / Cold	-29°C to 45°C (-20°F to 115°F)	80W-90 API GL5
	Arctic	-40°C to 45°C (-40°F to 115°F)	Shell Spirax S4 TXM 10W-30
Engine Oil	Standard / Cold	-18°C to 45°C (0°F to 115°F)	Petro-Canada Duron-E 10W-30, Esso XD-3 Extra Premium Heavy Duty 10W-30
	Arctic	-40°C to 45°C (-40°F to 115°F)	Petro-Canada Duron-E synthetic 0W-40, Esso XD-3 Extra 0W-40
Coolant	Standard / Cold	-40°C to 45°C (-40°F to 115°F)	Recochem 50/50 Premix (green)
	Arctic	-40°C to 45°C (-40°F to 115°F)	*Recochem 50/50 Premix (green) mixed with Recochem Extended Life Predilute 60/40 concentrate

*Add the concentrate antifreeze to the 50/50 mix to obtain a 60/40 concentration.

2146AA

2.14 Engines

Kubota D1305	RPM Settings	1400 Idle / 1700 Mid / 2600 High
	Horsepower @ 2000 rpm (intermittent)	18.4 kW / 25 hp
	Fuel Type	Diesel
	Fuel Tank Capacity	45 gal (170.3 L)
	Lube Oil Sump Capacity	2.38 gal (9 L)
	Coolant Capacity	3.0 gal (11.4 L)
Kubota WG972	RPM Settings	1400 Idle / 2100 Mid / 3000 High
	Horsepower @ 2300 rpm (intermittent)	18.4 kW / 25 hp
	Fuel Type	Diesel
	Fuel Tank Capacity	15 gal (60 L)
	Coolant Capacity	2.75 gal (10.4 L)
	Lube Oil Sump Capacity	2.11 gal (8.0 L)

2144AB

2.15 Reach Diagram

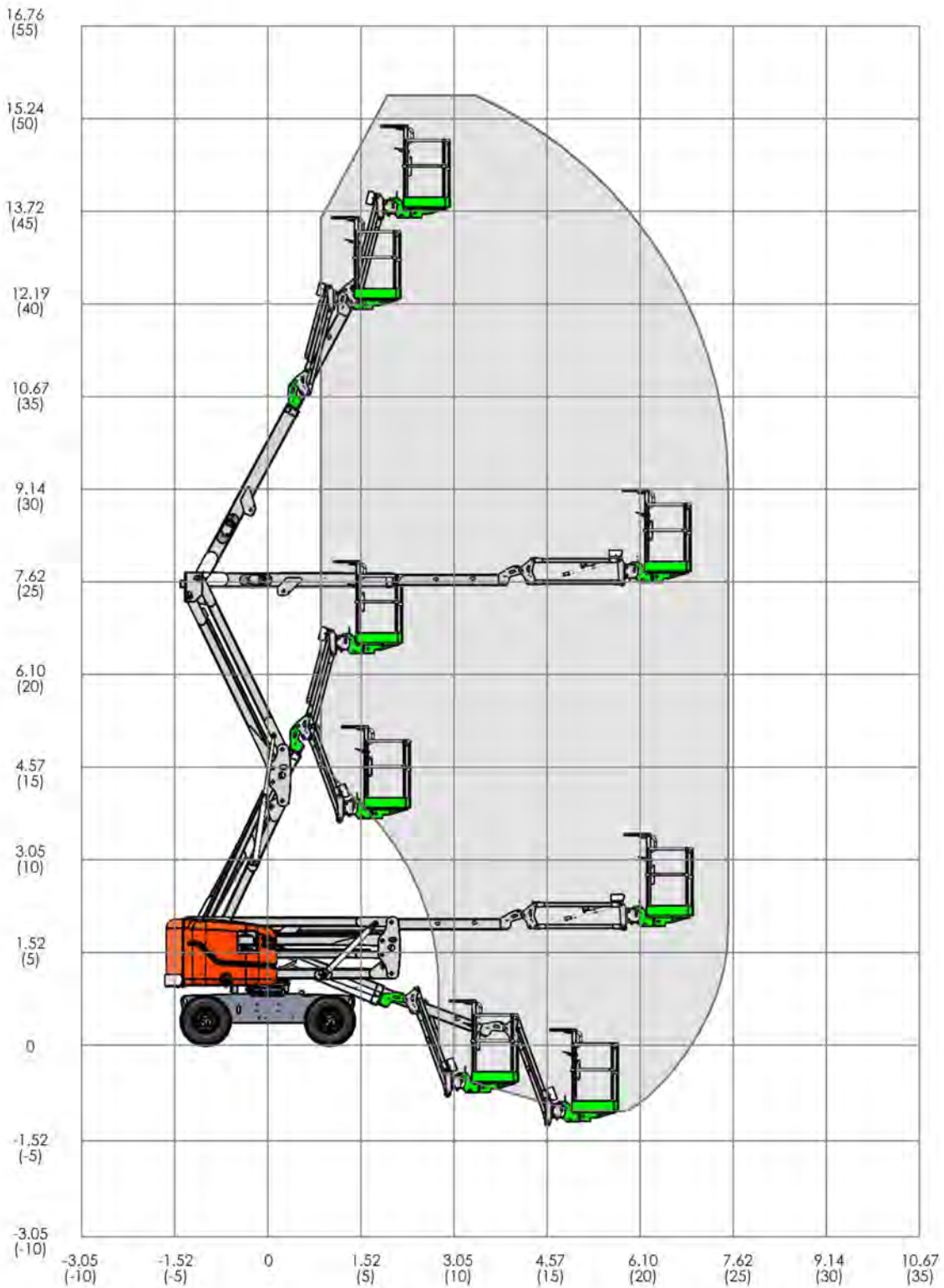

2.16 Dimension Diagrams

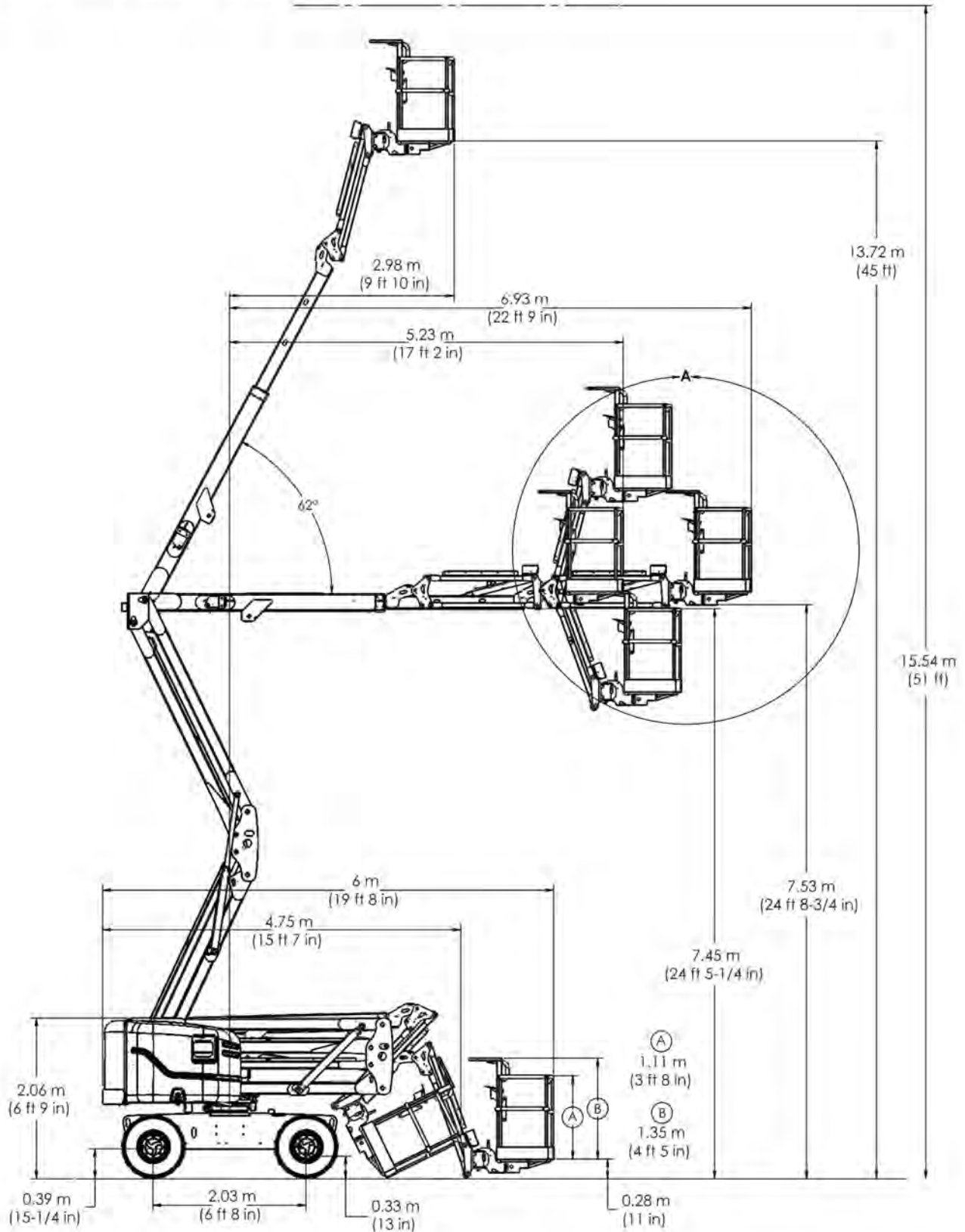

Dimension Diagrams (continued)

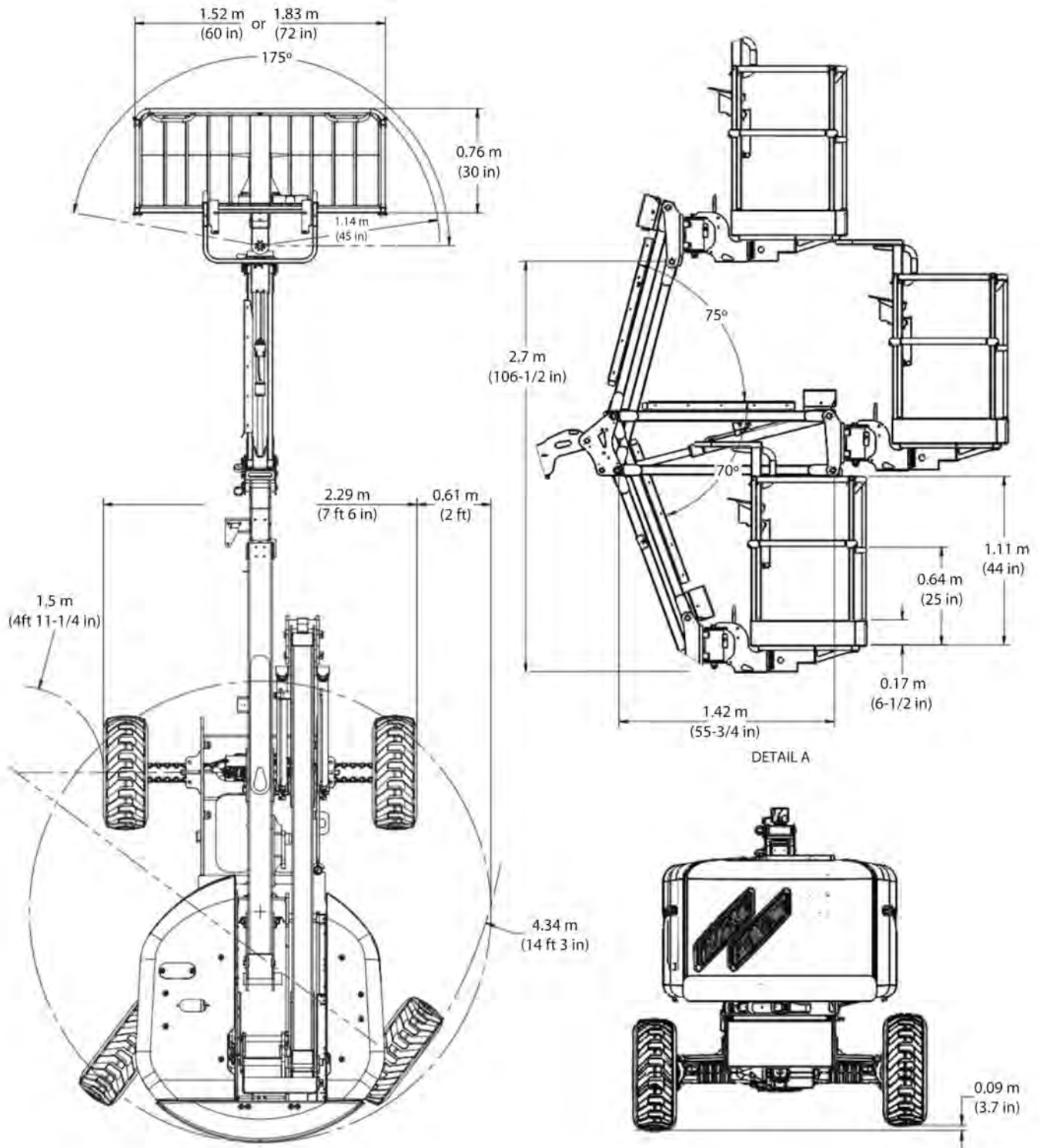

2.17 Axle Oscillation Diagram

⚠ WARNING

Do not raise the platform in work mode if the MEWP it is not on a firm level surface.

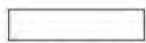
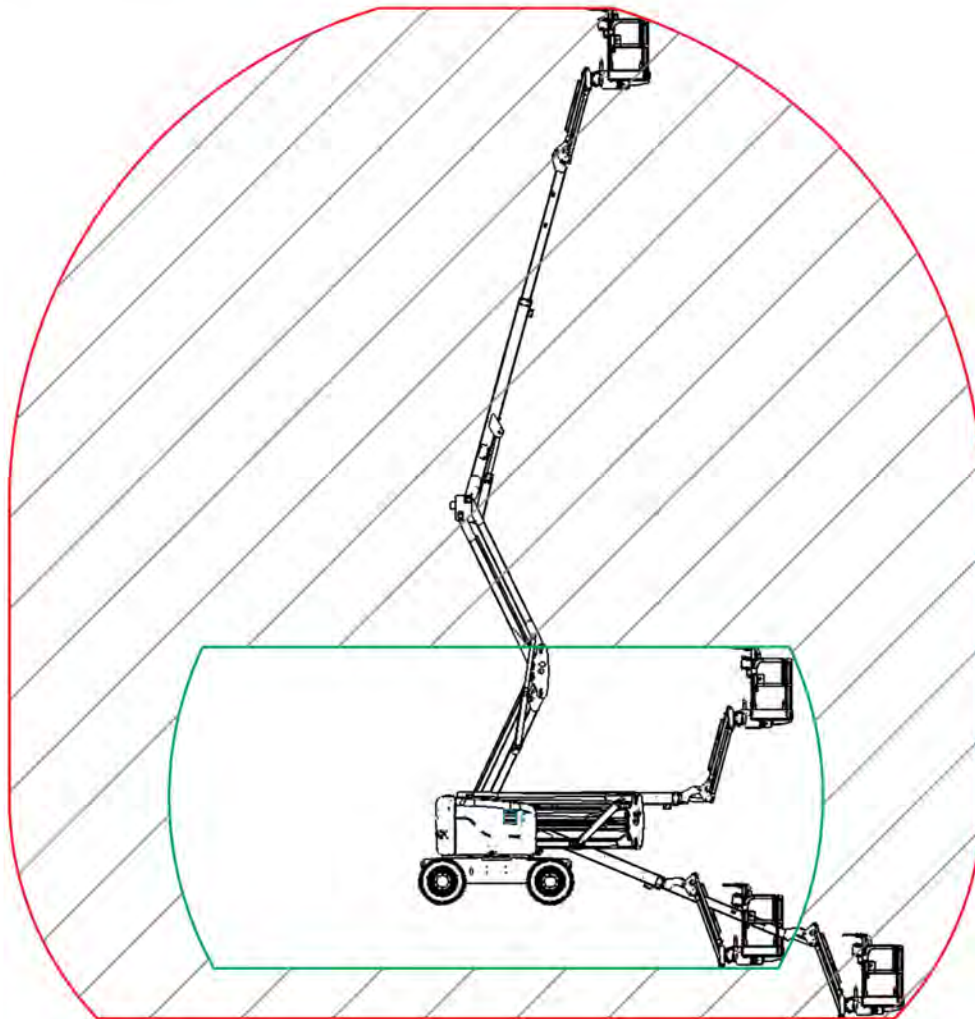

Axle oscillation free (travel mode) - drive speed 7.7 km/h (4.8 mph) max.

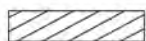

Axle oscillation locked (work mode) - drive speed 0.8 km/h (0.5 mph) max.

Section 3 – System Component Identification and Schematics

Table 3.1 Electrical Symbol Chart













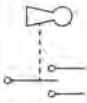







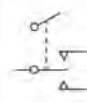



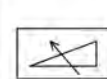
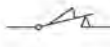













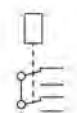



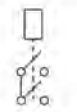

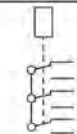



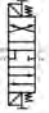



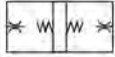

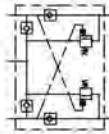



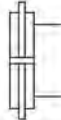

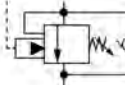





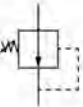

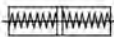

 CIRCUITS CROSSING NO CONNECTION	 HOURMETER	 KEY SWITCH	 LIMIT SWITCH
 CIRCUITS CONNECTED	 LIGHT	 FOOT SWITCH	 CAM OPERATED LIMIT SWITCH
 BATTERY	 HYDRAULIC VALVE COIL	 TOGGLE SWITCH	 LIMIT SWITCH N.O.
 GROUND	 PROPORTIONAL HYDRAULIC VALVE COIL	 ANGLE TRANSDUCER & TILT SWITCH	 LIMIT SWITCH N.O. HELD CLOSED
 FUSE	 ELECTRIC MOTOR	 TEMPERATURE SWITCH	 LIMIT SWITCH N.C.
 CIRCUIT BREAKER	 HORN	 SINGLE POLE SINGLE THROW RELAY	 LIMIT SWITCH N.C. HELD OPEN
 VOLT METER	 PUSH BUTTON	 SINGLE POLE DOUBLE THROW RELAY	 BEEPER
 CAPACITOR	 ROTARY SWITCH	 DOUBLE POLE DOUBLE THROW RELAY	 DIODE
 POTENTIOMETER	 EMERGENCY STOP BUTTON	 DOUBLE POLE SINGLE THROW RELAY	
 RESISTOR	 RHEOSTAT	 TRIPLE POLE DOUBLE THROW RELAY	

Table 3.2 Hydraulic Symbol Chart

 LINE CROSSING	 FIXED DISPLACEMENT PUMP	 SHUTTLE VALVE	 THREE POSITION FOUR WAY CLOSED CENTER OPEN PORT
 LINE JOINED	 VARIABLE DISPLACEMENT PUMP	 PRESSURE SWITCH	 CUSHION CYLINDER
 MAIN LINES Solid	 HAND PUMP	 MOTION CONTROL VALVE	 DOUBLE ACTING CYLINDER
 PILOT LINES Dashed	 OIL COOLER	 FLOW DIVIDER COMBINER	 DOUBLE ACTING DOUBLE RODDED CYLINDER
 HYDRAULIC TANK	 VELOCITY FUSE	 COUNTER BALANCE VALVE	 BRAKE CYLINDER
 HYDRAULIC FILTER WITH BYPASS	 RELIEF VALVE	 VALVE COIL	 SPRING APPLIED HYDRAULIC RELEASED BRAKE
 ELECTRIC MOTOR	 PRESSURE REDUCING VALVE	 TWO POSITION TWO WAY NORMALLY OPEN VALVE	 ROTARY ACTUATOR
 ENGINE	 PRESSURE TRANSDUCER	 TWO POSITION TWO WAY NORMALLY CLOSED VALVE	 SERVO
 BI DIRECTIONAL HYDRAULIC MOTOR	 FIXED ORIFICE	 TWO POSITION THREE WAY VALVE	
 VARIABLE DISPLACEMENT HYDRAULIC MOTOR	 ADJUSTABLE FLOW CONTROL	 TWO POSITION THREE WAY VALVE	
 SERIES PARALLEL HYDRAULIC MOTOR	 CHECK VALVE	 THREE POSITION FOUR WAY CLOSED CENTER CLOSED PORT	

3.3 Wire Number and Colour Chart

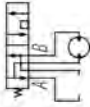
Wire No.	Wire Colour	Wire No.	Wire Colour
B+	GREEN/PURPLE	34	ORANGE/BLACK
0	WHITE	35	ORANGE/WHITE
1	PURPLE/BLACK	36	RED/PURPLE
2	WHITE	37	WHITE/RED/BLACK
3	GREEN/PURPLE	38	ORANGE/RED
4	RED/YELLOW	39	BLACK/RED
5	PURPLE	40	BLUE/RED
7	RED	41	BLUE/PURPLE
9	YELLOW	42	PINK
10	BLUE/WHITE	45	YELLOW/ORANGE
11	WHITE/ORANGE	49	GREEN/RED
12	RED/BLACK/YELLOW	55	YELLOW/PURPLE
13	ORANGE	57	BROWN/GREEN
14	BLACK	59	YELLOW/BLUE
15	BLUE	65	YELLOW/PINK
16	WHITE/BLACK	68	GREY
17	BLUE/GREEN	74	GREEN/GREY
20	ORANGE/BLUE	76	BROWN/BLUE
21	WHITE/RED	77	BROWN/GREY
23	BLACK/WHITE	85	GREY/BLUE
24	BLUE/BLACK	108	YELLOW/BROWN
26	BLUE/YELLOW	118	PURPLE/PINK
28	GREEN	119	PURPLE/YELLOW
29	GREY/ORANGE(BLACK)	120	GREY/BROWN
30	RED/GREEN	121	GREY/RED
31	RED/WHITE	122	GREY/YELLOW
32	GREEN/BLACK	128	BLACK/YELLOW
33	GREEN/WHITE	165	PINK/BLACK

This table is a wire number/colour reference for all electrical drawings and schematics. All wire numbers retain their original colour coding; for example if wire 7 is red, wires 7A, 7B, and 7C are also red.

2178AB

3.4 Hydraulic Parts List

Index No.	Skyjack Part No.	Description
2H-21A	166039	VALVE (Dump)
2H-42	231438	VALVE, Proportional
3H-21	195036	VALVE, Control (Load Circuit)
3H-26	159827	VALVE, Control (Brake Release)
3H-38	166037	VALVE, Control (Boom Retract)
3H-39	166037	VALVE, Control (Boom Extend)
3H-45A	159827	VALVE, Control (2 Speed Motor)
3H-65	159827	VALVE, Control (Axle Lockout)
3H-85	168448	VALVE, Generator Bypass (3.5kW Generator)
4H-13	166041	VALVE, Control (Main Boom Lift Down)
4H-14	166041	VALVE, Control (Main Boom Lift Up)
4H-23A	158186	VALVE, Control (Steering Left)
4H-24A	158186	VALVE, Control (Steering Right)
4H-30	166041	VALVE, Control (Riser Down)
4H-31	166041	VALVE, Control (Riser Up)
4H-32	166041	VALVE, Control (Turret Rotate Left)
4H-33	166041	VALVE, Control (Turret Rotate Right)
4H-34	166036	VALVE, Control (Jib Down)
4H-35	166036	VALVE, Control (Jib Up)
4H-36	166036	VALVE, Control (Platform Rotate Left)
4H-37	166036	VALVE, Control (Platform Rotate Right)
4H-40	166036	VALVE, Control (Platform Level Down)
4H-41	166036	VALVE, Control (Platform Level Up)
C1	218750	CYLINDER (Jib)
C2	148712	CYLINDER (Fly Boom)
C3	238369	CYLINDER (Main Boom Lift)
C4	148715	CYLINDER (Platform Level, Master)
C5	148716	CYLINDER (Platform Level, Slave)
C6	148710	CYLINDER (Riser Lift)
C7	148710	CYLINDER (Riser Lift)
C9	212871	RAM (Axle Lockout)
C10	212871	RAM (Axle Lockout)
CB1	212872	VALVE, Counterbalance (Axle Lockout)
CB2	212872	VALVE, Counterbalance (Axle Lockout)
CB3	220533	VALVE, Counterbalance (Swing Drive)
CB4	220533	VALVE, Counterbalance (Swing Drive)
CB5	149488	VALVE, Counterbalance (Riser Down)
CB6	149488	VALVE, Counterbalance (Riser Down)
CB7	149228	VALVE, Counterbalance (Platform Level, Slave)
CB8	149228	VALVE, Counterbalance (Platform Level, Slave)
CB9	152326	VALVE, Counterbalance (Boom Lift)
CB10	149228	VALVE, Counterbalance (Fly Boom Extend)
CB11	141453	VALVE, Counterbalance (Fly Boom Retract)
CB12	149372	VALVE, Counterbalance (Jib)

3.4 Hydraulic Parts List

Index No.	Skyjack Part No.	Description
CB13	149372	VALVE, Counterbalance (Jib)
CB14	141399	VALVE, Counterbalance (Rotary Actuator)
CB15	141399	VALVE, Counterbalance (Rotary Actuator)
CP1	231437	PLUG, Cavity
CV2	171413	VALVE, Check (Brake Manifold)
CV3	166064	VALVE, Check (Main Control)
CV4	159817	VALVE, Check (Double, Piloted, Platform Level)
CV5	163183	VALVE, Check (Riser)
CV6	163182	VALVE, Check (Riser)
CV7	166067	VALVE, Check (LS)
CV8	166067	VALVE, Check (LS)
CV9	166067	VALVE, Check (LS)
CV10	166067	VALVE, Check (LS)
CV11	166067	VALVE, Check (LS)
CV12	166067	VALVE, Check (LS)
DSV1	166059	VALVE, System Load Sense (Differential Sensing Valves)
DSV2	166062	VALVE, Differential Sensing (Boom Rotate)
DSV3	166063	VALVE, Differential Sensing (Riser)
DSV4	166063	VALVE, Differential Sensing (Main Lift)
DSV5	166062	VALVE, Differential Sensing (Jib/Platform Rotate)
EPU	160923	PUMP, Emergency Power Unit
F1	161932	FILTER, High Pressure
F2	161934	FILTER, Return
M1	161964	MOTOR, Drive
MB1	218327	MANIFOLD, Main
MB2	168642	MANIFOLD, Brake
MB3	231501	MANIFOLD, Jib
OR1	167353	ORIFICE, Main Control (Platform Rotate)
OR2	167352	ORIFICE, Main Control (Jib)
OR3	166056	ORIFICE, Main Control (Boom Extend)
OR4	166057	ORIFICE, Main Control (Platform Level)
OR5	171420	ORIFICE, Brake Manifold (Loop Flush)
OR6	163710	ORIFICE, Riser Down (0.067")
OR7	195033	VALVE, Needle (Load Circuit)
P1	170599	PUMP, Hydrostatic
P1A	170599	PUMP, Charge
P2	161963	PUMP, System
PFC1	166055	CONTROL, Priority Flow (Steer)
PFC2	169407	CONTROL, Priority Flow (Generator 3.5kW)
PR1	168754	VALVE, Pressure Reducing
QD1	122420	DISCONNECT, Quick
RA1	144710	ACTUATOR, Platform
RA2	216673	WORM GEAR, Slew drive
RV6	166043	VALVE, Relief (Main Control)
RV7	238568	VALVE, Relief (Boom Rotate)
RV8	166044	VALVE, Relief (Riser Down)

3.4 Hydraulic Parts List

Index No.	Skyjack Part No.	Description
RV9	238569	VALVE, Relief (Platform Level)
RV10	195600	VALVE, Relief (3.5 kW Generator Option)
RV11	238571	VALVE, Relief (12 kW Generator Option)
RV12	195596	VALVE, Relief (3.5 kW Generator Option)
RV13	195035	VALVE, Relief (Load Circuit)
RV15	238570	VALVE, Relief (Load Circuit)
RV16	238571	VALVE, Relief (12 kW Generator Option)
SV1	141414	SHUTTLE VALVE, Brake Manifold (LS)
SV2	166054	SHUTTLE VALVE, Brake Manifold (M1 / M2)
SV4	166054	SHUTTLE VALVE, Main Manifold (Swing)
SV5	166054	SHUTTLE VALVE, Main Manifold (Riser)
SV6	166054	SHUTTLE VALVE, Main Manifold (Boom Lift)
SV7	166054	SHUTTLE VALVE, Main Manifold (Platform Level)
SV8	166054	SHUTTLE VALVE, Main Manifold (Platform Level)
V1	141436	VALVE, Control (Brake Release Override)
V2	166053	VALVE, Control (Loop Flush)
V3	159831	HAND PUMP (Brake Release)

3.5 Electrical Parts List

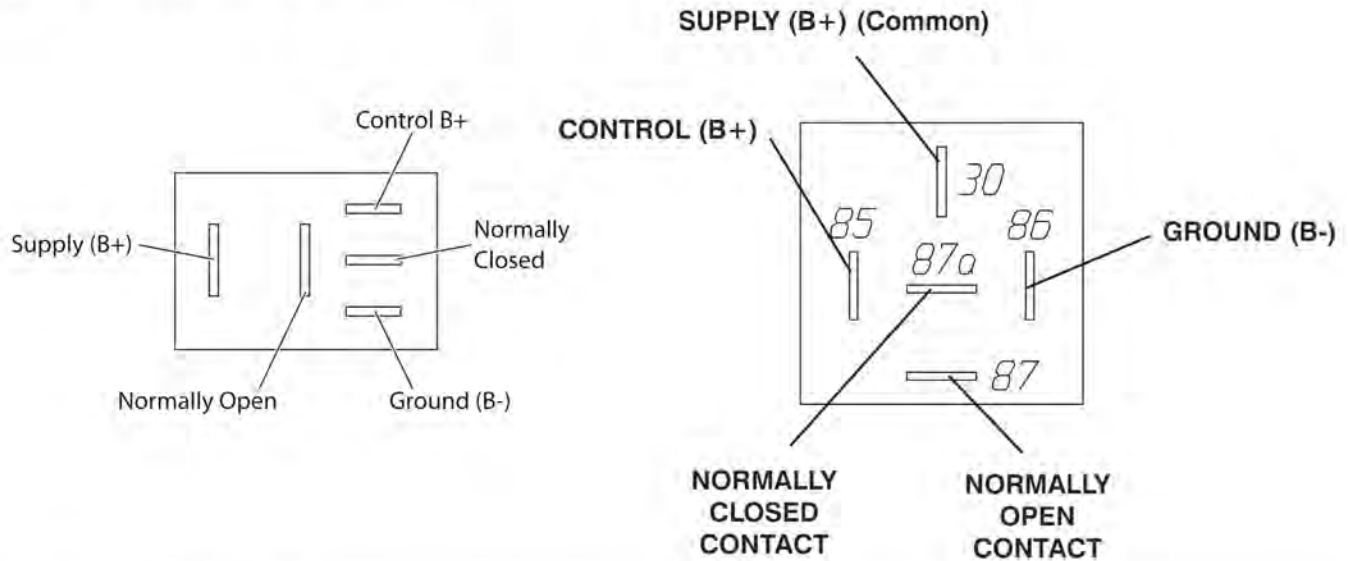

Index No.	Skyjack Part No.	Description
01ACR	931298	RELAY, Micro 12 V DC, 30 amp (Base control console)
04ACR	931298	RELAY, Micro 12 V DC, 30 amp (Base control console)
07CR	127131	RELAY, 12 Volt 40 Amp (Base control console - E-pump/Enable)
08CR	127131	RELAY, 12 Volt 40 Amp (Platform control console - Footswitch/Starter interlock)
09CR	127131	RELAY, 12 Volt 40 Amp (Engine power on)
21CR	127131	RELAY, 12 Volt 40 Amp (Base control console - Dump valve)
27CR	127131	RELAY, 12 Volt 40 Amp (Platform control console - Tilt alarm)
45CR1	127131	RELAY, 12 Volt 40 Amp (Base control console - 2-SPD motor)
45CR2	127131	RELAY, 12 Volt 40 Amp (Base control console - 2-SPD motor controller)
49CR	931298	RELAY, Micro 12 V DC, 30 amp (Base control console)
57ACR	127131	RELAY, 12 Volt 40 Amp (Base control console - Engine Start)
57DCR	931298	RELAY, Micro 12 V DC, 30 amp (Base control console)
60CR	127131	RELAY, 12 Volt 40 Amp (Base control console - System power)
78CR	127131	RELAY, 12 Volt 40 Amp (Base control console - High idle)
79CR	127131	RELAY, 12 Volt 40 Amp (Base control console - Low idle)
82CR	127131	RELAY, 12 Volt 40 Amp (Platform control console - Load sensing alarm)
165CR	127131	RELAY, 12 Volt 40 Amp (Platform control console - Differential lock)
403ACR	931298	RELAY, Micro 12 V DC, 30 amp (Base control console - Positive air shut-off option)
2H-21A	159819	COIL, 12 Volt (Dump valve)
2H-34A	159821	COIL, 12 Volt (Jib enable valve)
2H-36A	159821	COIL, 12 Volt (Platform rotate enable valve)
3H-26	159827	COIL, 12 Volt (Brake valve)
3H-45	159827	COIL, 12 Volt (Motor 2-speed valve)
3H-65	159827	COIL, 12 Volt (Axle lock valve)
3H-165	159827	COIL, 12 Volt (Differential lock valve)
4H-13	159819	COIL, 12 Volt (Boom down valve)
4H-14	159819	COIL, 12 Volt (Boom up valve)
4H-23A	159819	COIL, 12 Volt (Right steer valve)

3.5 Electrical Parts List

Index No.	Skyjack Part No.	Description
4H-24A	159819	COIL, 12 Volt (Left steer valve)
4H-30	159819	COIL, 12 Volt (Riser down valve)
4H-31	159819	COIL, 12 Volt (Riser up valve)
4H-32	159819	COIL, 12 Volt (Left turret rotate valve)
4H-33	159819	COIL, 12 Volt (Right turret rotate valve)
4H-34	159821	COIL, 12 Volt (Jib down valve)
4H-35	159821	COIL, 12 Volt (Jib up valve)
4H-36	159821	COIL, 12 Volt (Platform left rotate valve)
4H-37	159821	COIL, 12 Volt (Platform right rotate valve)
4H-38	159821	COIL, 12 Volt (Boom retract valve)
4H-39	159821	COIL, 12 Volt (Boom extend valve)
4H-40	159821	COIL, 12 Volt (Platform level down valve)
4H-41	159821	COIL, 12 Volt (Platform level up valve)
A1	138224	JOYSTICK (Fly boom/Turret)
A2	138225	JOYSTICK (Drive/Steer)
A3	148707	JOYSTICK (Riser boom)
AT1	149426	ANGLE TRANSDUCER
B1	144676	BATTERY, 12V (Wet)
BP1	103057	BEEPER, 4-28 VDC Slow pulsing (Platform control console)
BP2	103056	BEEPER, 7.5-16 VDC (Base control console)
BP3	144387	ALARM, Overload
CB1	117325	CIRCUIT BREAKER (15 Amp)
CB2	117325	CIRCUIT BREAKER (15 Amp)
CB3	117325	CIRCUIT BREAKER (15 Amp)
CB4	117326	CIRCUIT BREAKER (20 Amp)
CB6	117326	CIRCUIT BREAKER (20 Amp)
CI	152323	INDICATOR, Charge
DXX	102921	DIODE
FU1	138848	FUSE, 50 Amp
FS1	138230	SWITCH, Low fuel
H1	146652	HORN, 12 Volt
LS1	122007	SWITCH, Limit (Direction sensing)
LS2	111356	SWITCH, Limit (Riser down)
LS3	161582	SWITCH, Limit (Boom down)
LS4	160018	SWITCH, Limit (Fly in)
M1	706921	PUMP, Emergency
PL1	148971	LIGHT, Pilot (Engine fault)
PL2	148972	LIGHT, Pilot (Glow plug)
PL3	147229	LED BLOCK, Red (12 volts) (Base control console)
PL4	147229	LED BLOCK, Red (12 volts) (Platform control console)
PL5	138229	MODULE, Upper indicating
PL6	148971	LIGHT, Pilot (Platform control console)
QD1	122420	QUICK DISCONNECT
R1	110999	RESISTOR, 5 ohm 25 W
R2	151643	RESISTOR, 250 ohm 1 W

3.5 Electrical Parts List

Index No.	Skyjack Part No.	Description
R3	163021	RESISTOR, 120 ohm 1/2 W
R4	164859	RESISTOR, 2.2k ohm 1/2 W
R5	143952	RESISTOR, 51 ohm 2 W
R6	164857	RESISTOR, 3.9k ohm 1/2 W
R7	144492	RESISTOR, 680 ohm 1 W
S1	119725	SWITCH, Main power disconnect
S2	218354	KEYSWITCH, Base/Off/Platform (Base control) - ANSI/CSA & AS
	218920	KEYSWITCH, Base/Off/Platform (Base control) - CE
S3	147053	N.C. CONTACT, Emergency stop (Base control console)
S4	147053	N.C. CONTACT, Emergency stop (Platform control console)
S5	138278	SWITCH, Ignition/emergency pump toggle (Base control console)
S6	138278	SWITCH, Ignition/emergency toggle (Platform control console)
S8	102853	SWITCH, Diagnose toggle (Base control console) (Deutz engine)
S9	124446	SWITCH, Ignition (Platform control console)
S10	115574	SWITCH, Throttle toggle (Platform control console)
S11	138721	ASSEMBLY, Footswitch
S12	138278	SWITCH, Boom up/down toggle (Base control console)
S13	102853	SWITCH, Turret rotate toggle (Base control console)
S14	102853	SWITCH, Telescope in/out toggle (Base control console)
S15	102853	SWITCH, Platform leveling toggle (Base control console)
S16	102853	SWITCH, Platform rotate toggle (Base control console)
S17	102853	SWITCH, Jib up/down toggle (Base control console)
S18	138278	SWITCH, Telescope in/out toggle (Platform control console)
S19	138278	SWITCH, Platform leveling toggle (Platform control console)
S20	138278	SWITCH, Platform rotate toggle (Platform control console)
S21	138278	SWITCH, Jib up/down toggle (Platform control console)
S23	147054	N.O. CONTACT, Horn (Platform control console)
S25	138278	SWITCH, Riser boom up/down toggle (Base control console)
S26	115574	SWITCH, Fuel select (Platform control console) (GM engine)
S28	148998	SWITCH, Differential (Platform control console)
S48	115747	SWITCH, Drive torque toggle (Platform control console)
SMB1-105	238028	MODULE, Master
SMB1-106	218382	MODULE, Slave
TT1	103336	HOUR METER

3.6 Brake Manifold Components and Ports

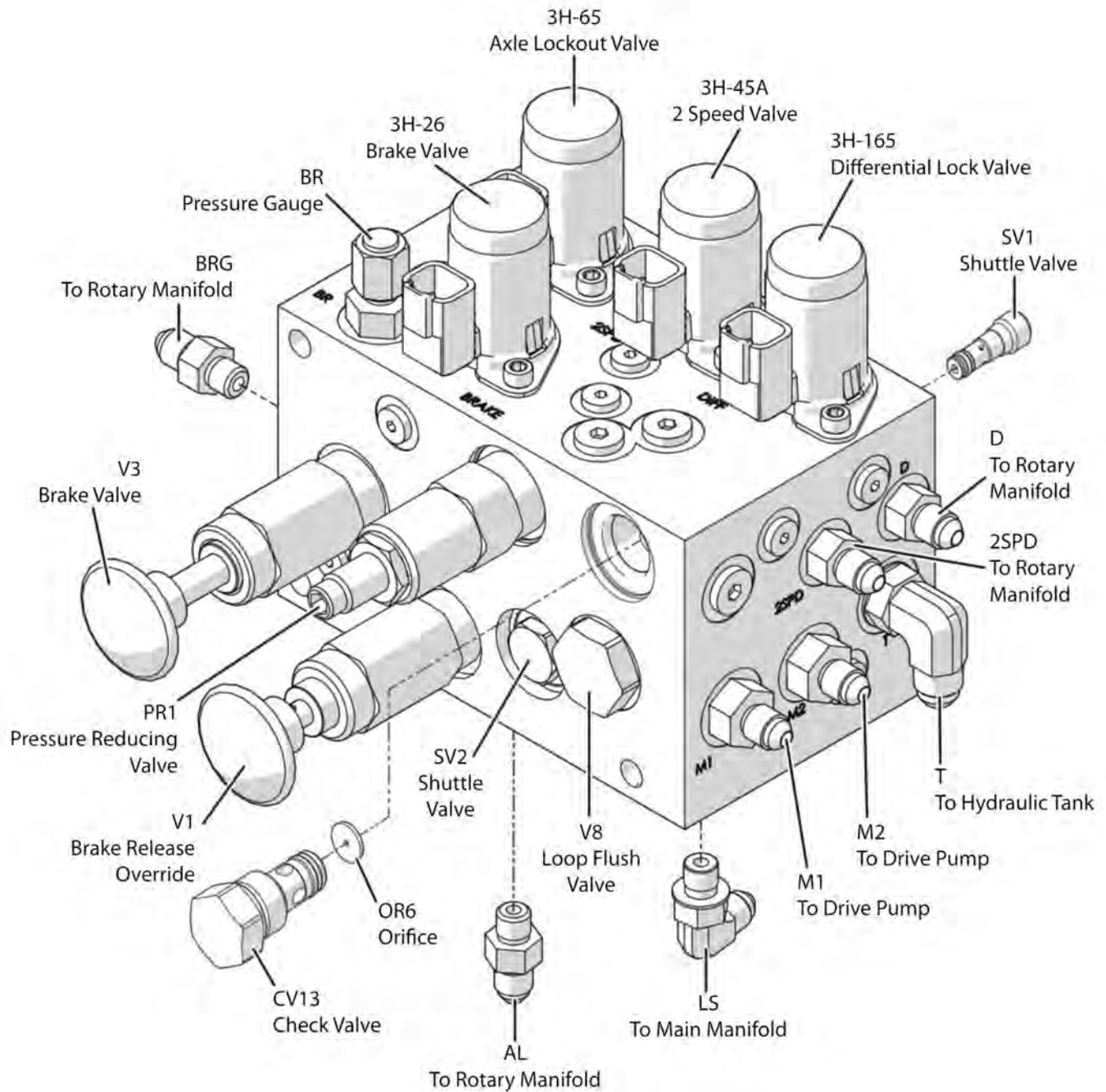

3.7 Drive and System Pump Ports

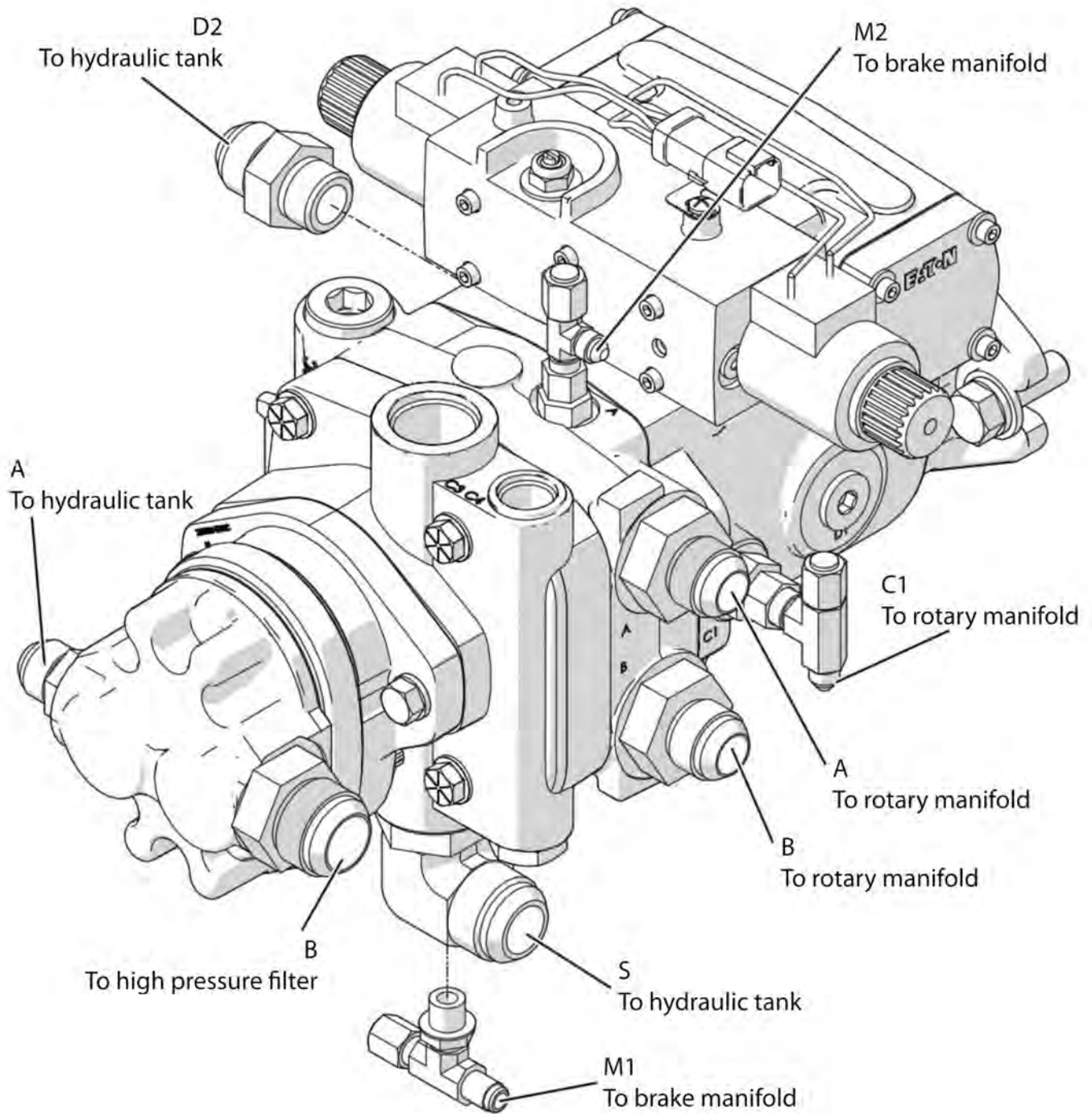

3.8 Drive Motor Ports

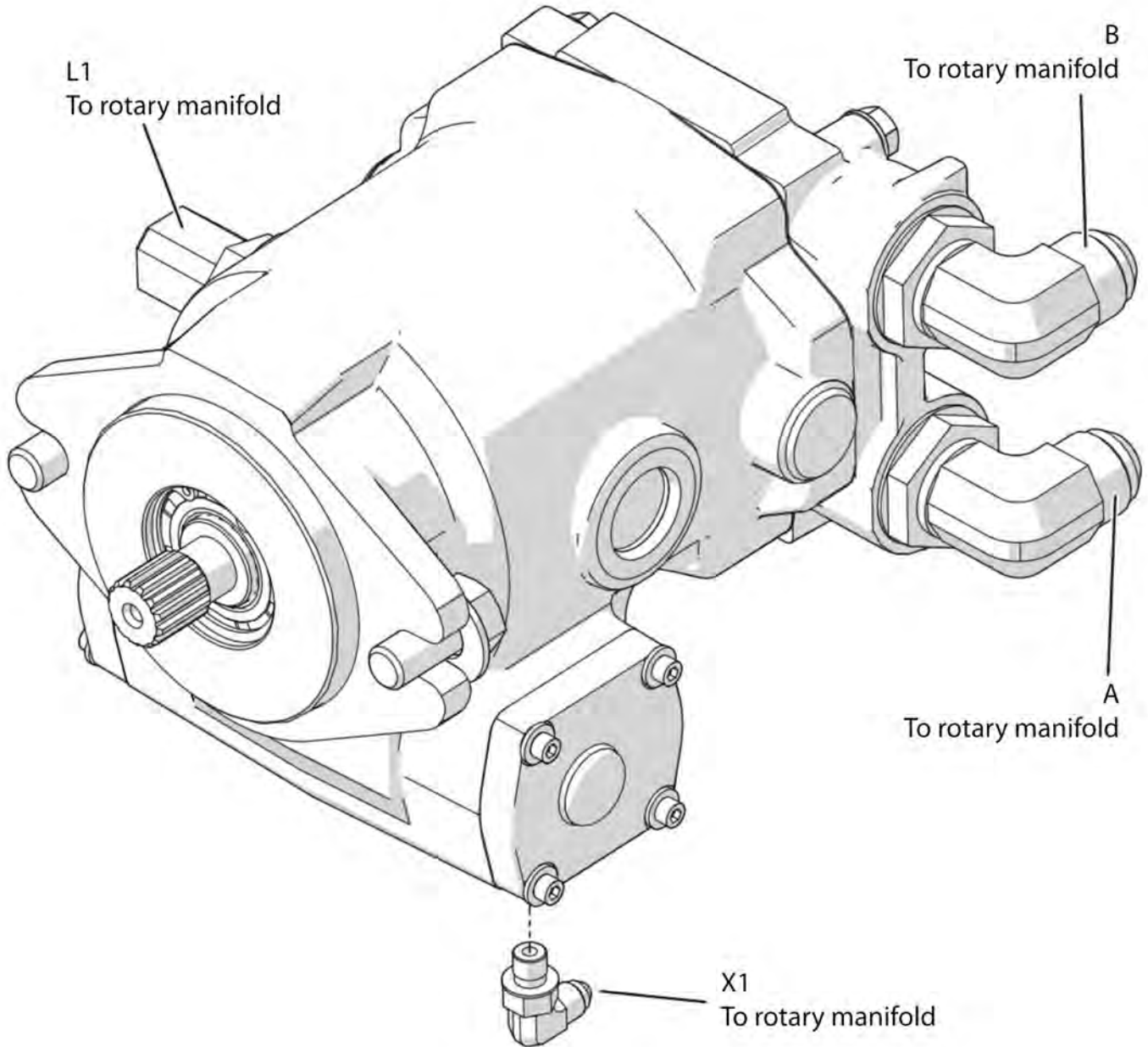

3.9 Jib Valve Ports

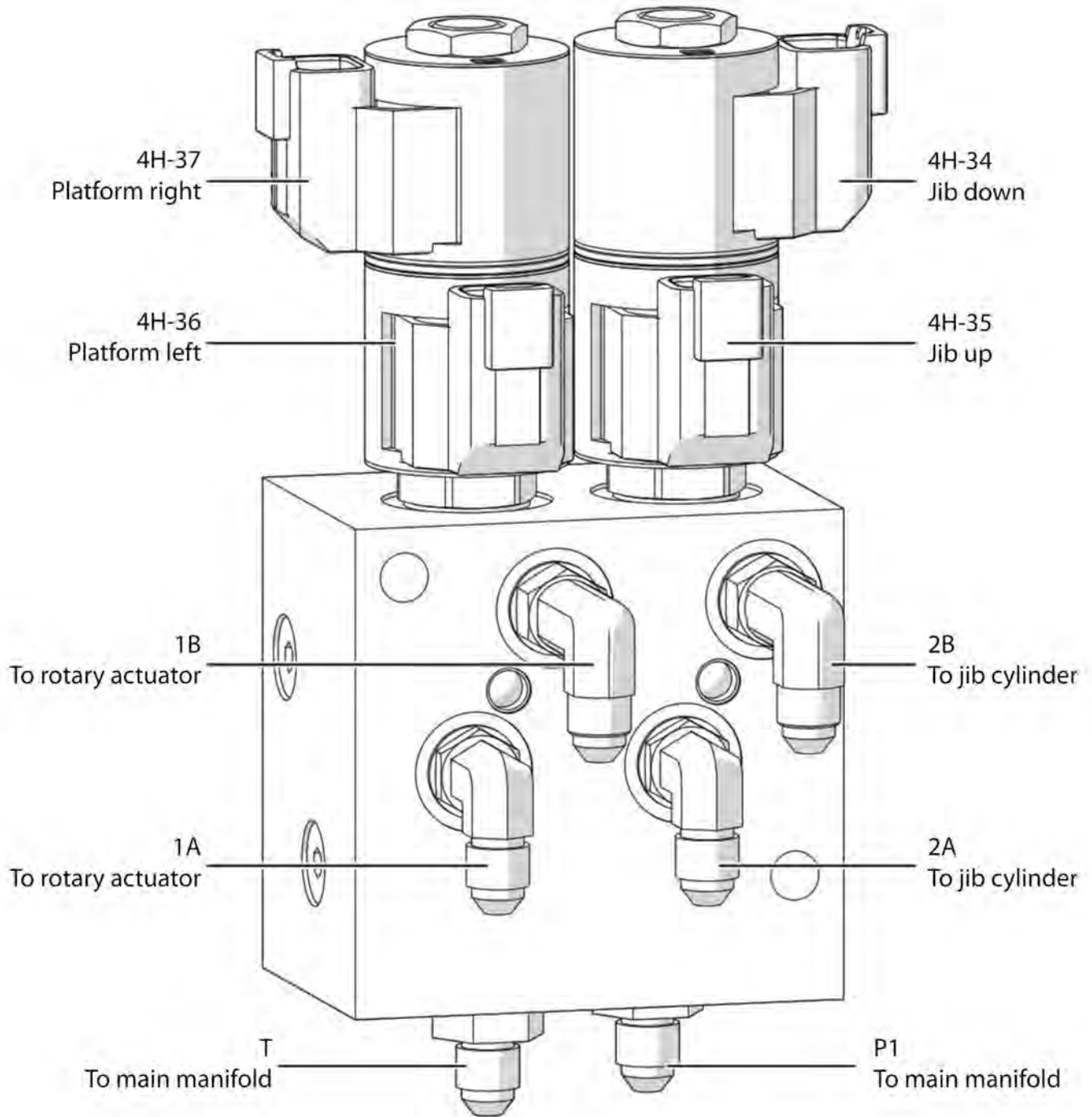

3.10 Main Manifold Ports

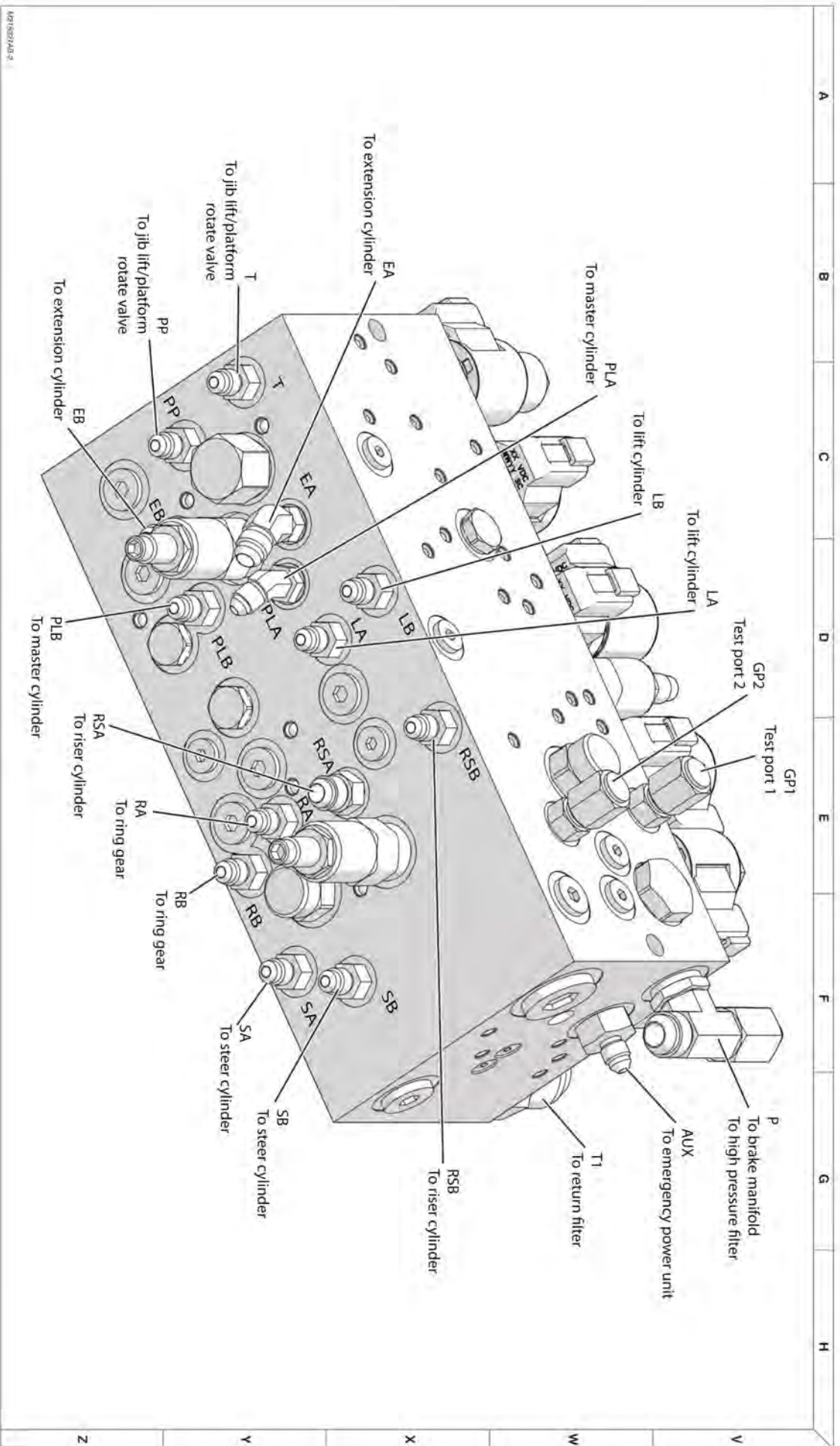

3.11 Main Manifold Electrical Components

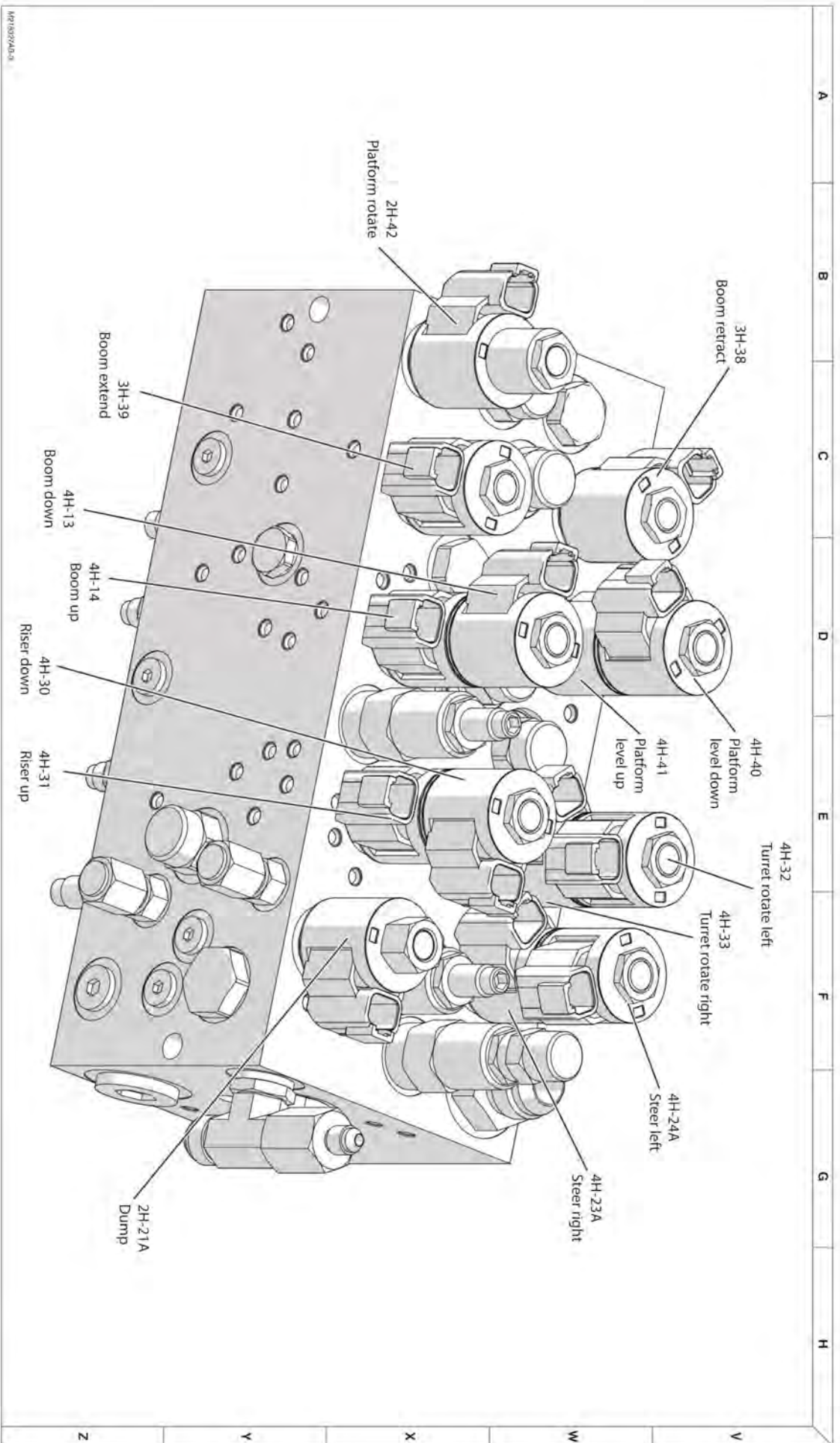

MP18029A3.0

280274A04

64

3.12 Main Manifold Hydraulic Components

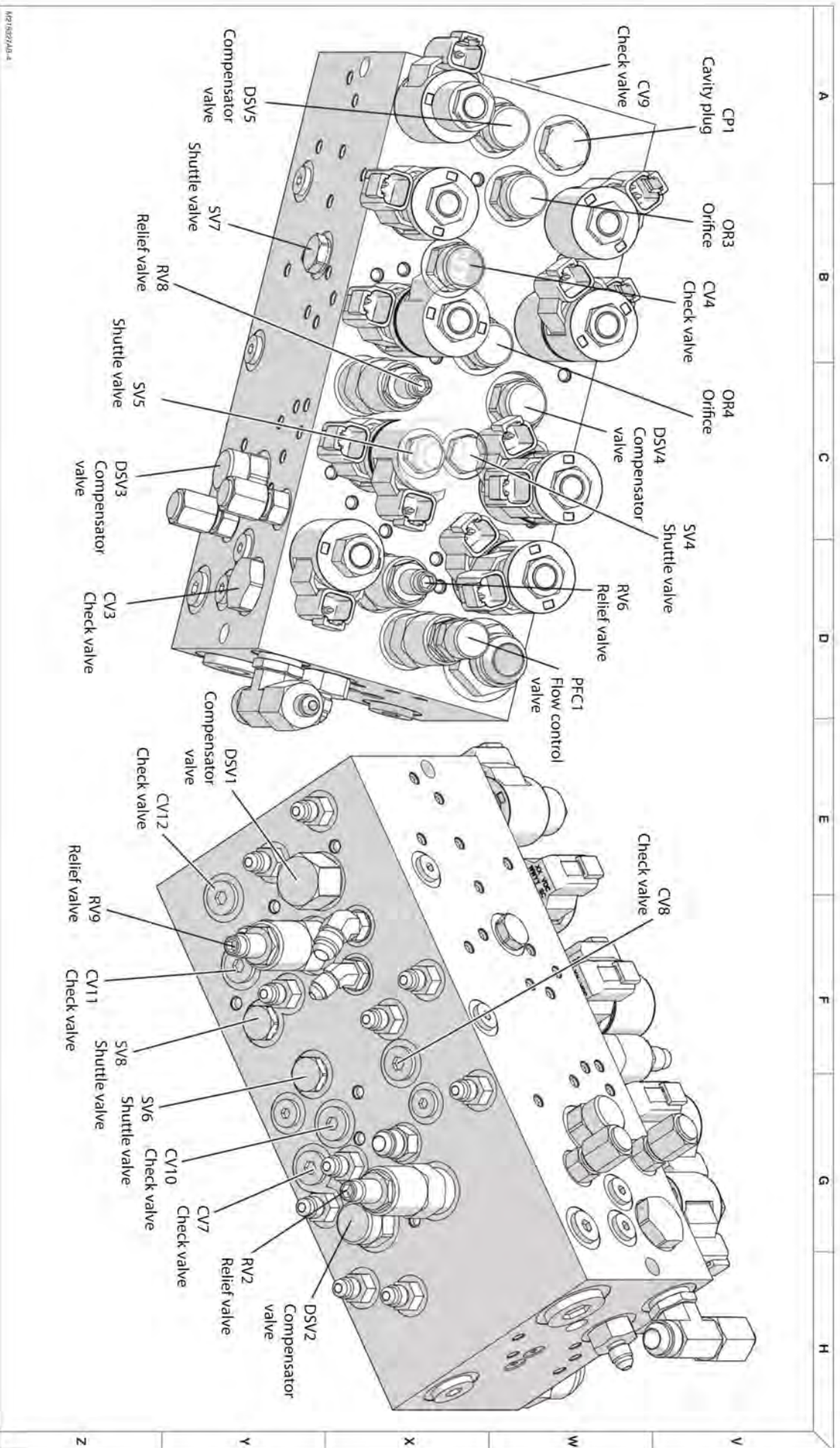

3.13 Major Components

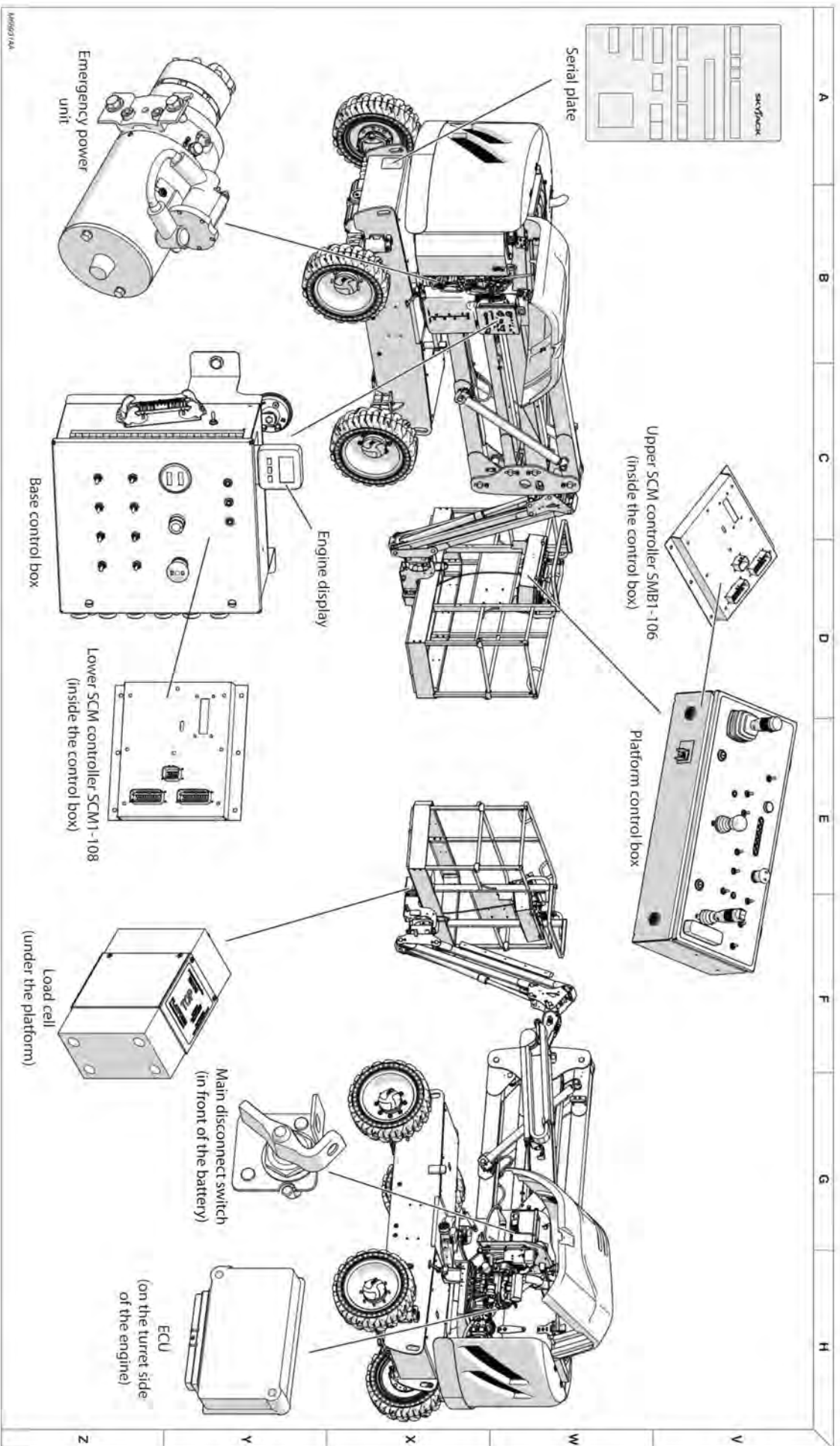

3.16 Engine Harness Wiring Diagram - D1305

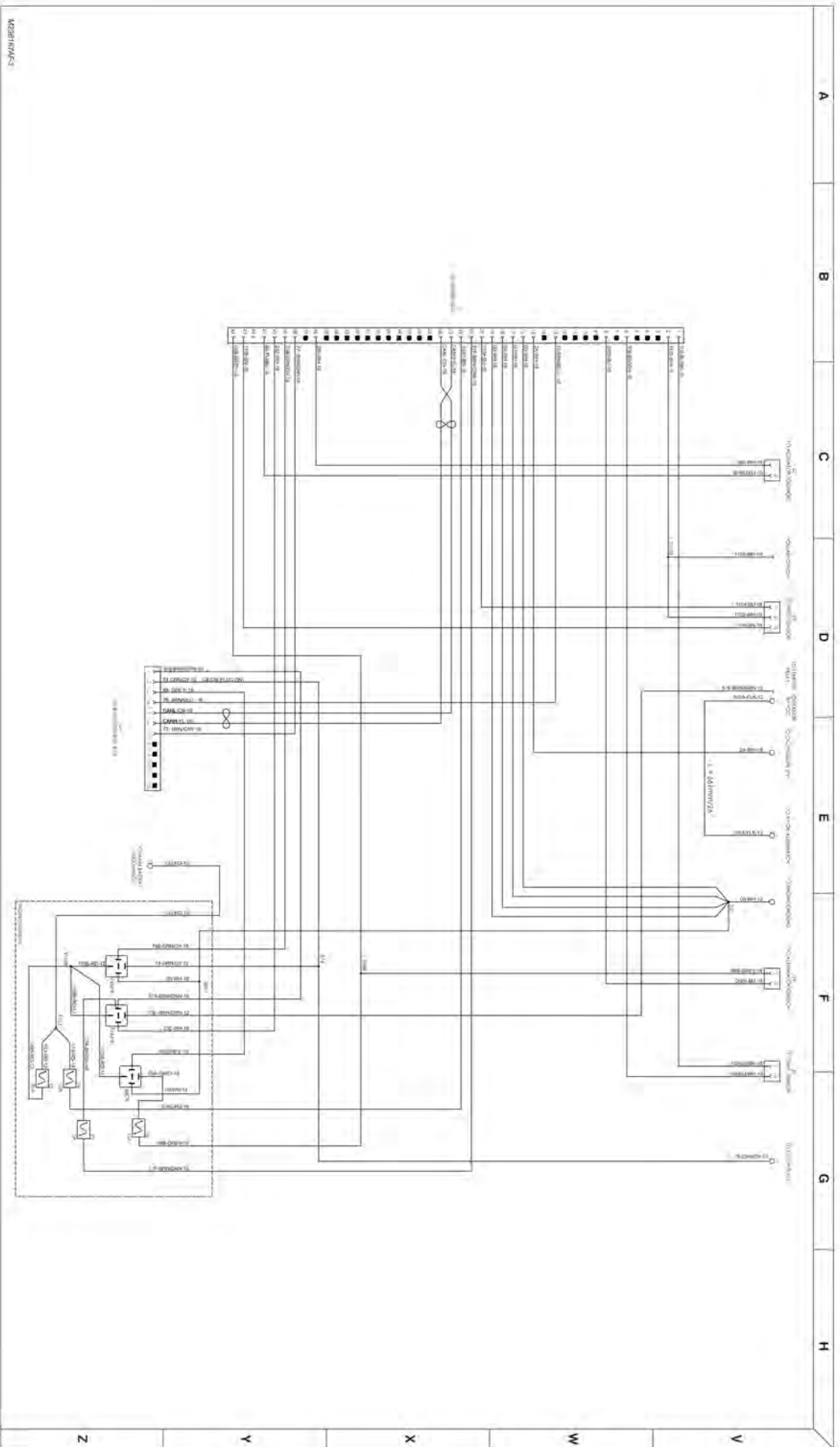

3.17 Engine Harness - WG972

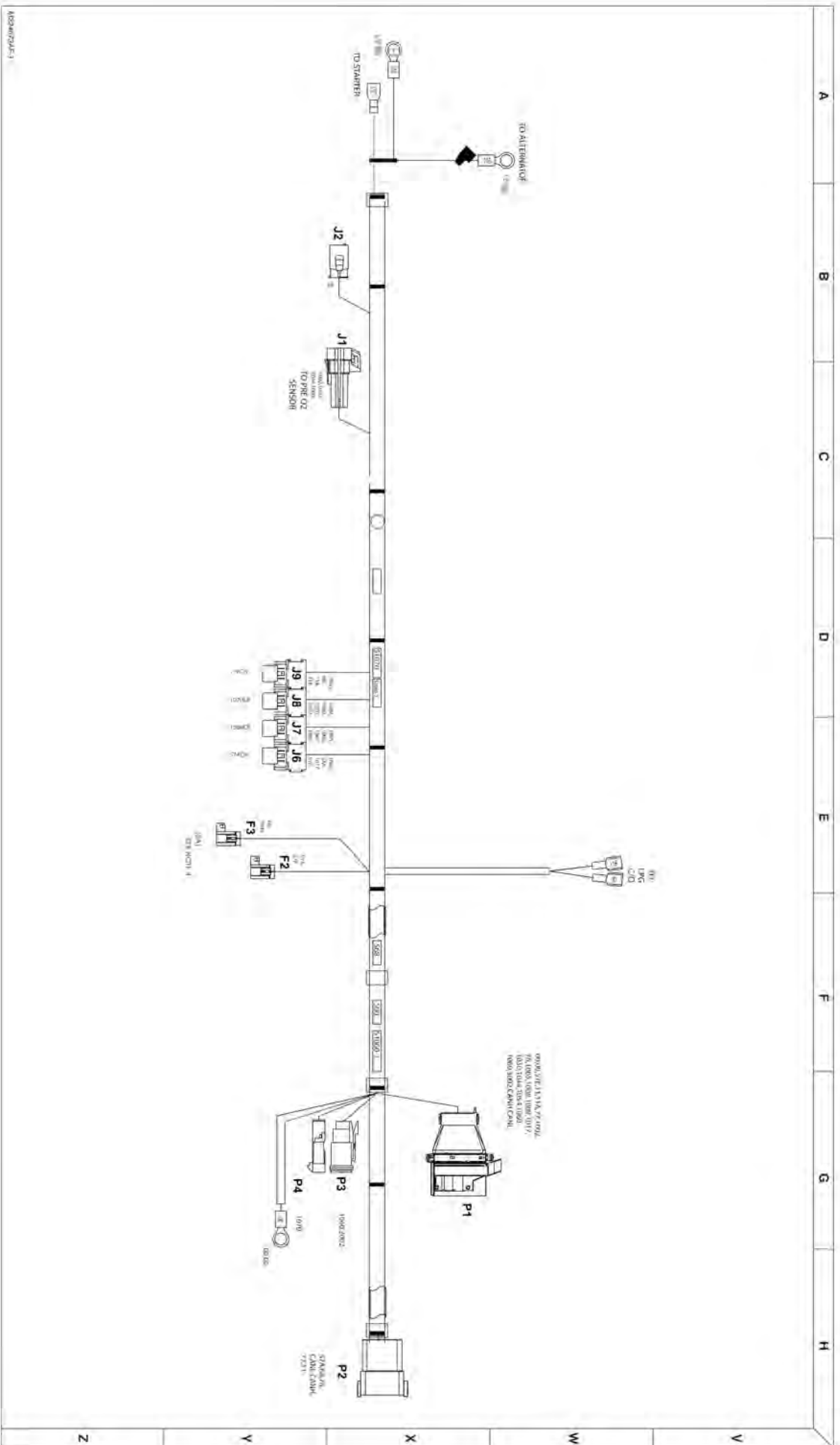

3.18 Engine Harness Wiring Diagram - WG972

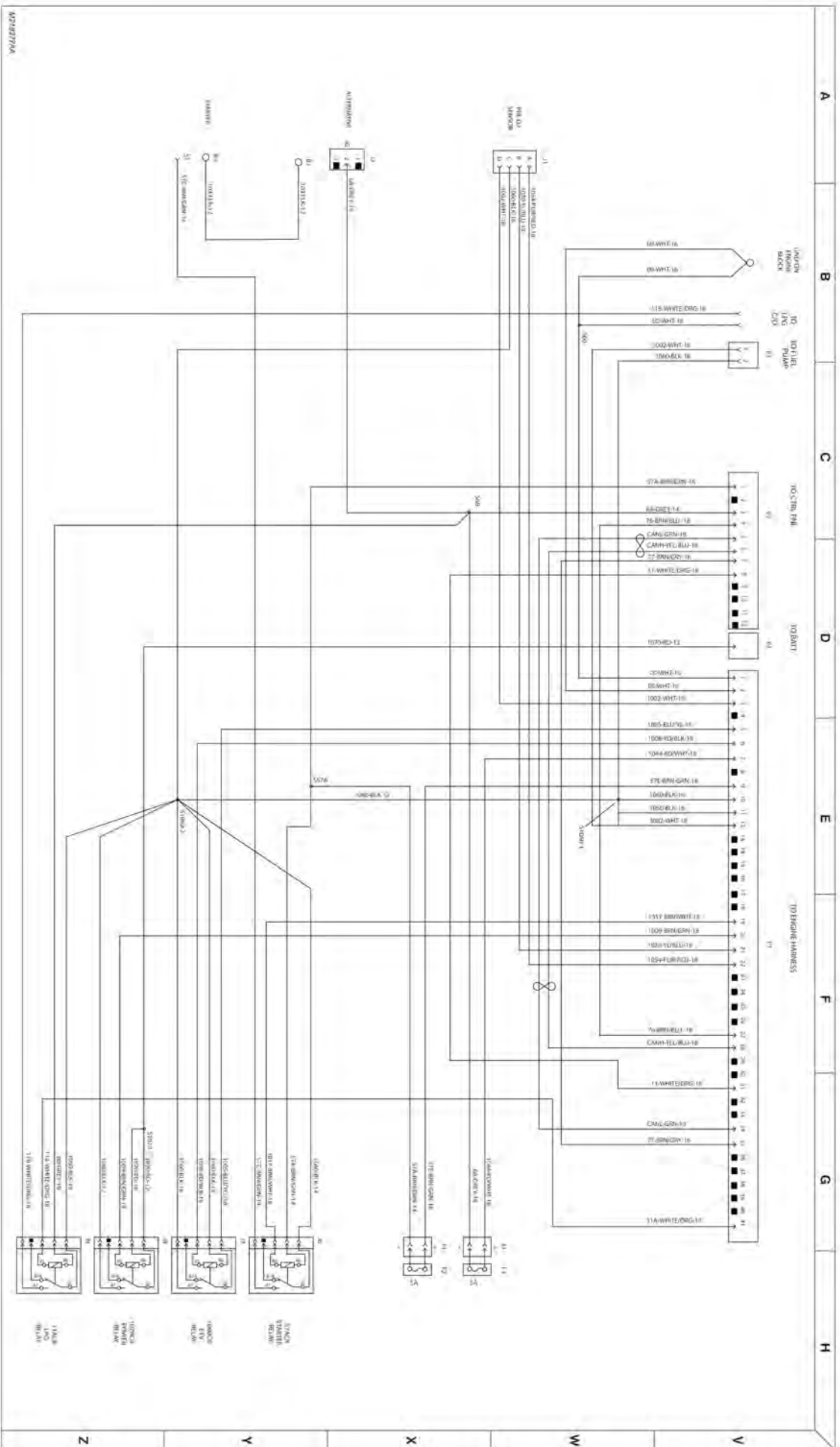

3.19 Jib and Platform Rotate Harness

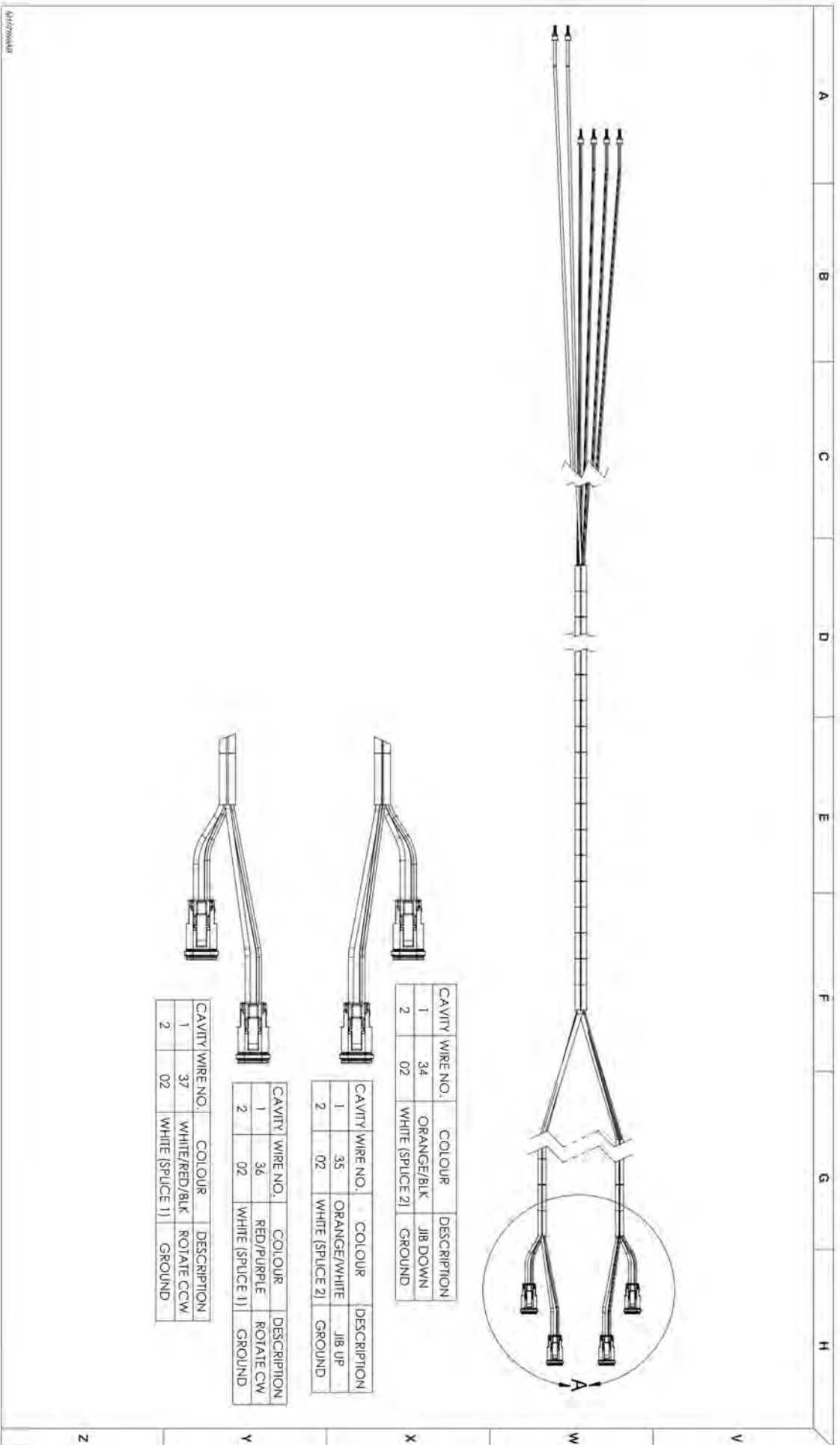

3.20 Limit Switch Connections

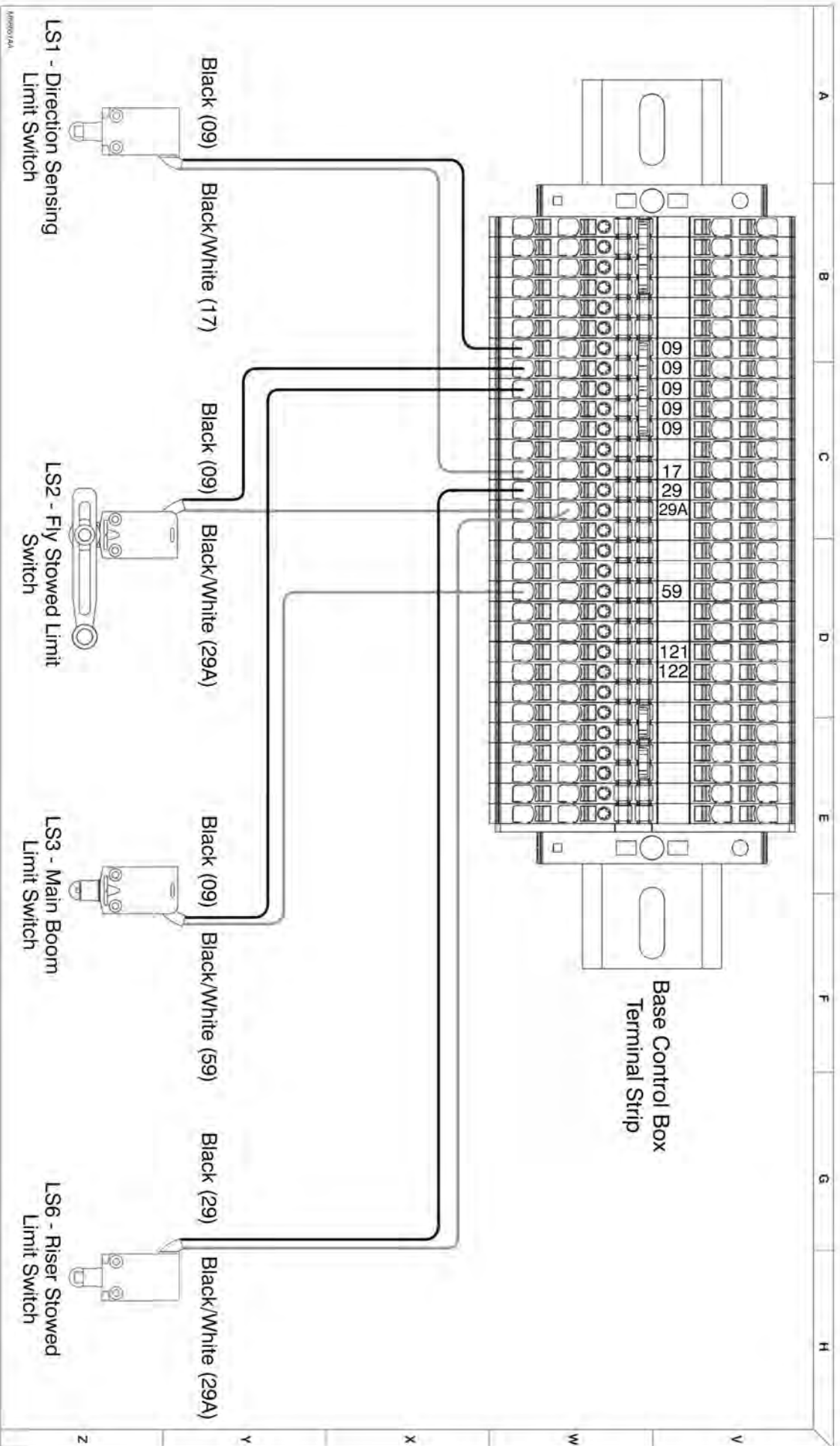

3.21 SGE Connections

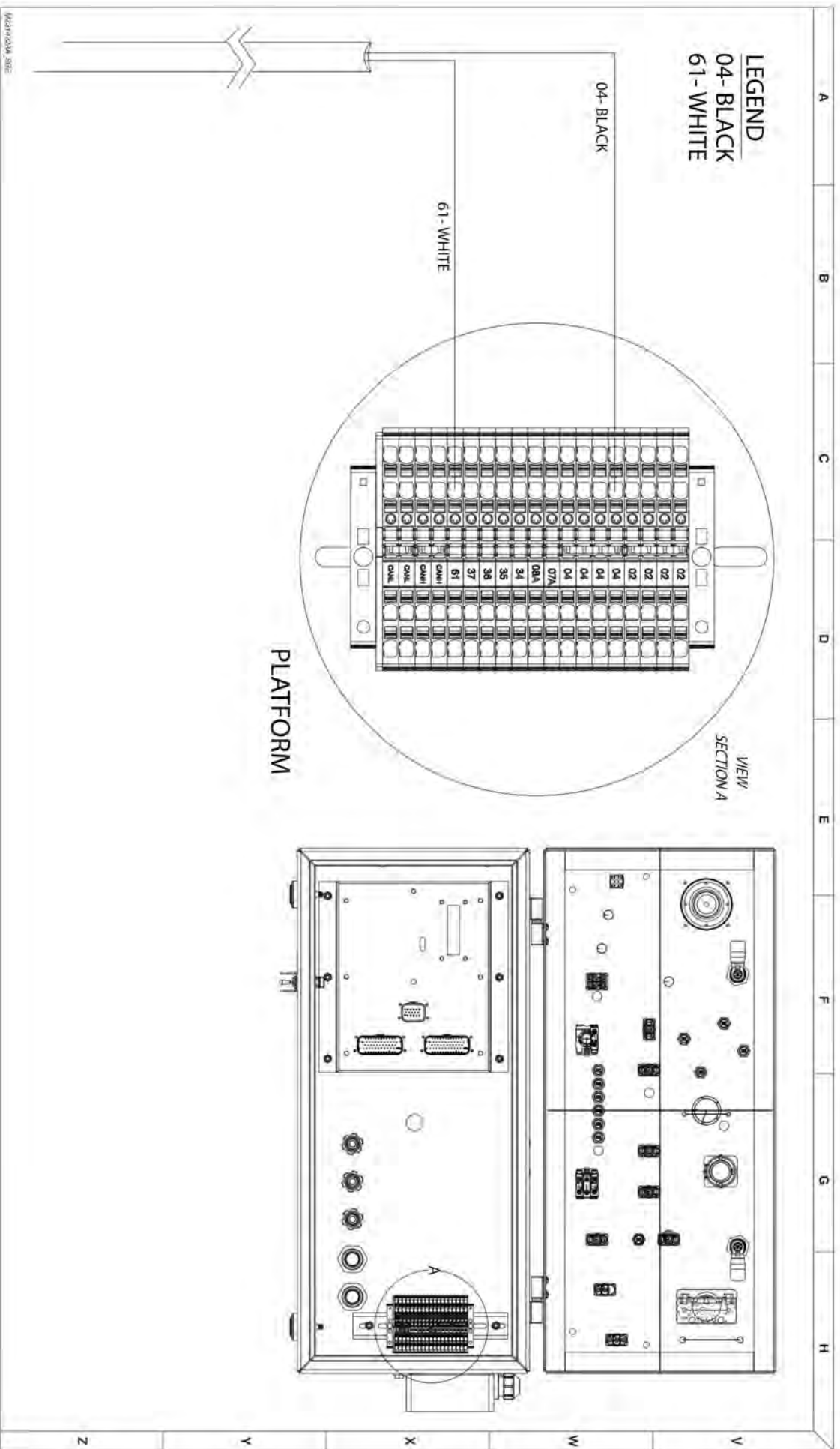

3.22 Moba Load Cell Connections

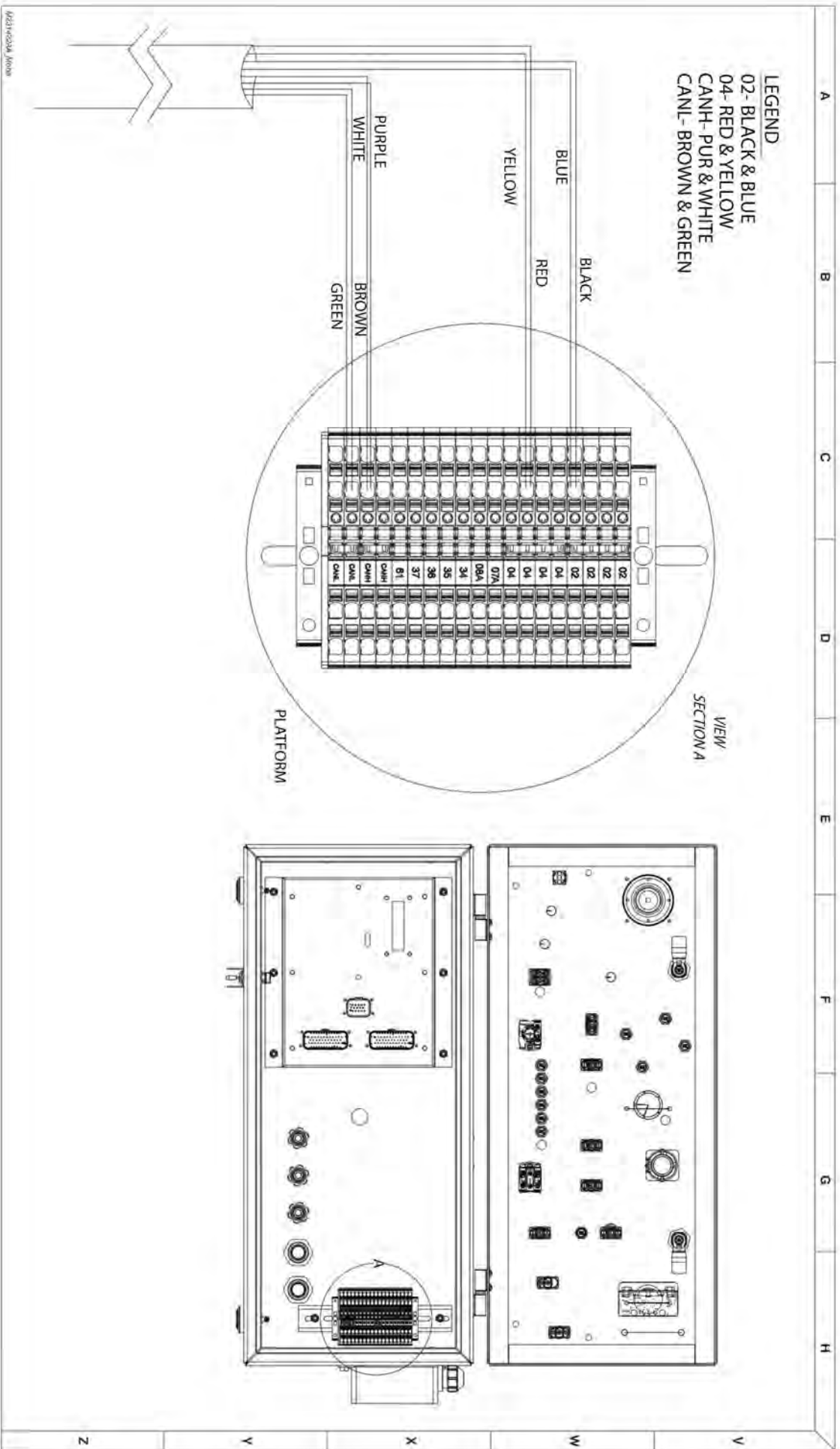

3.24 CANbus Cable Connections

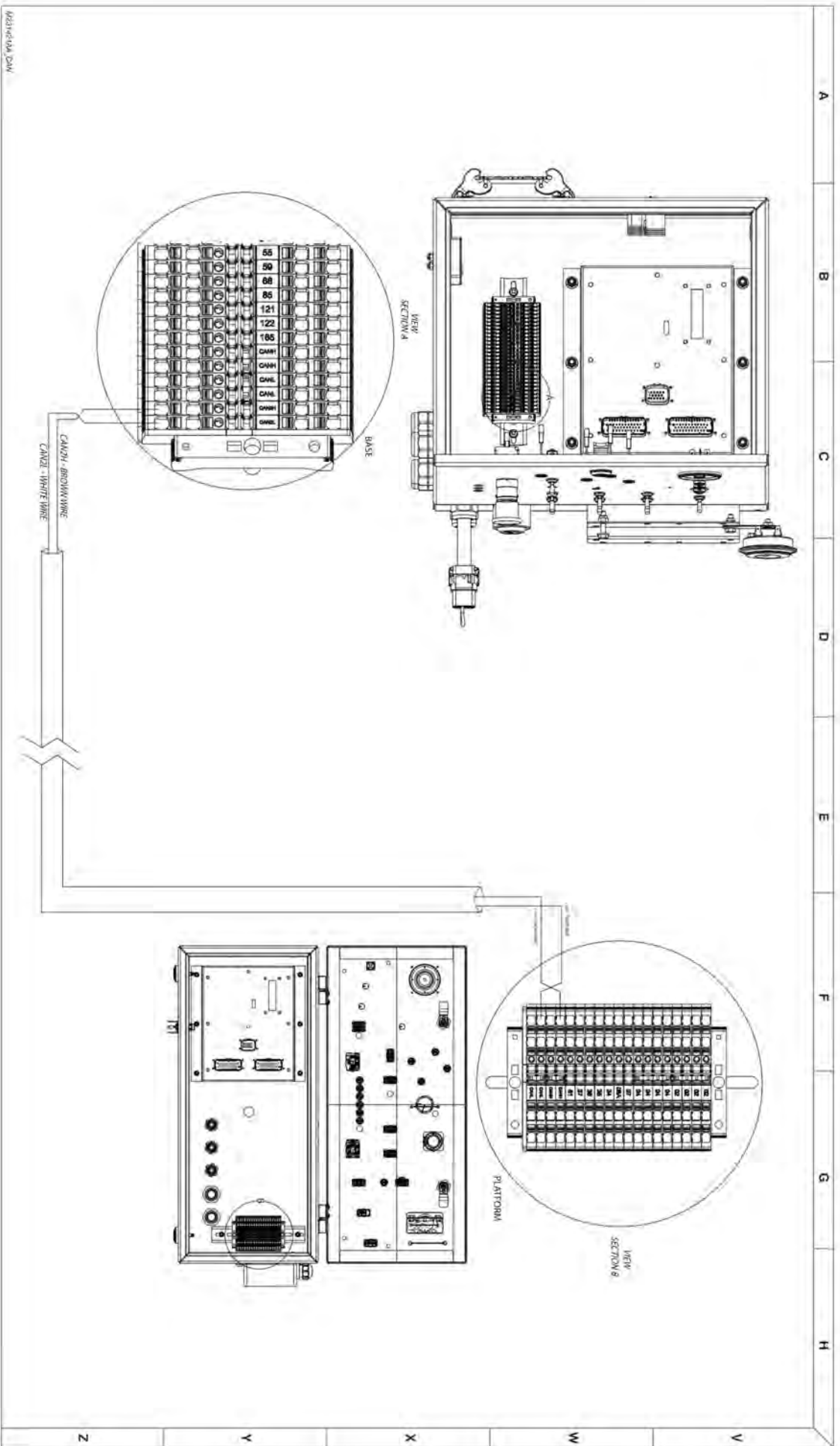

3.25 Power Cable Connections

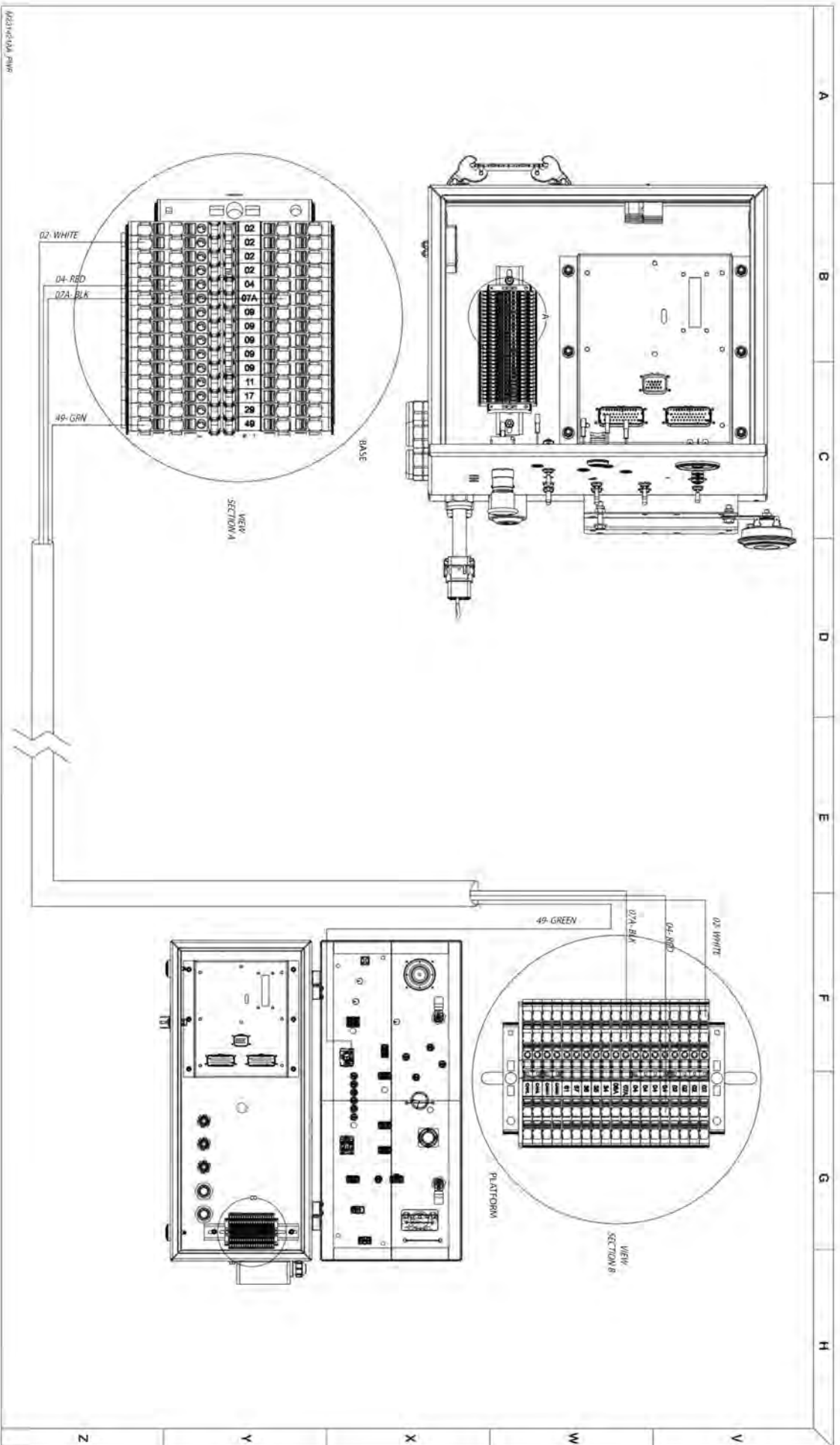

3.26 All Motion Alarm Connections - CE & AS

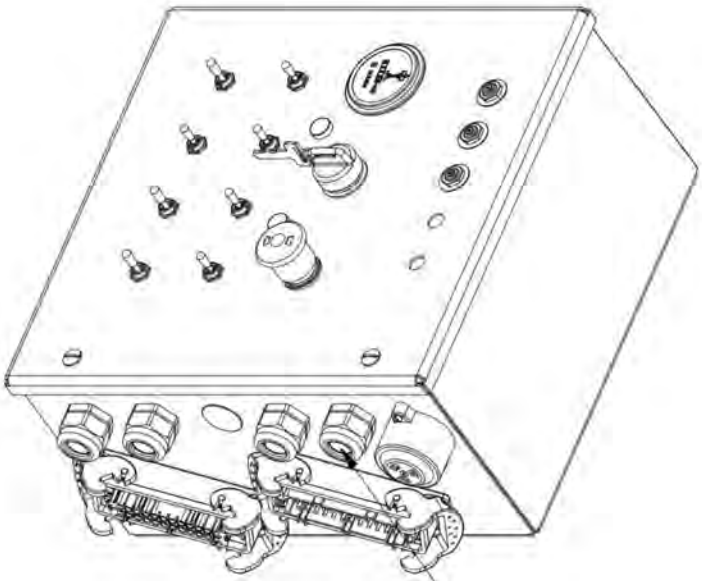

PASS WIRES THROUGH
TOP MOST STRAIN RELIEF
(LOOSEN GLAND FIRST)

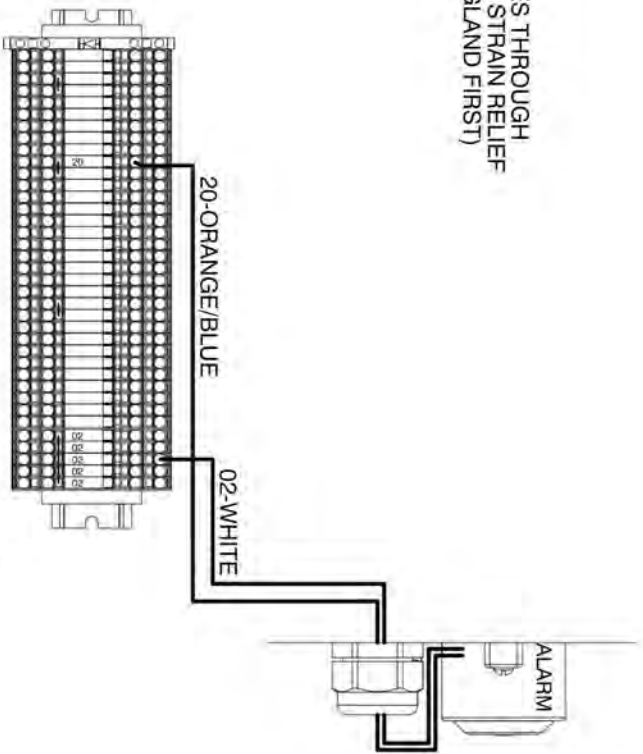

-WIRE INSTALLATION-

	A	B	C	D	E	F	G	H
V								
W								
X								
Y								
Z								

3.27 Flashing Amber Light Connections

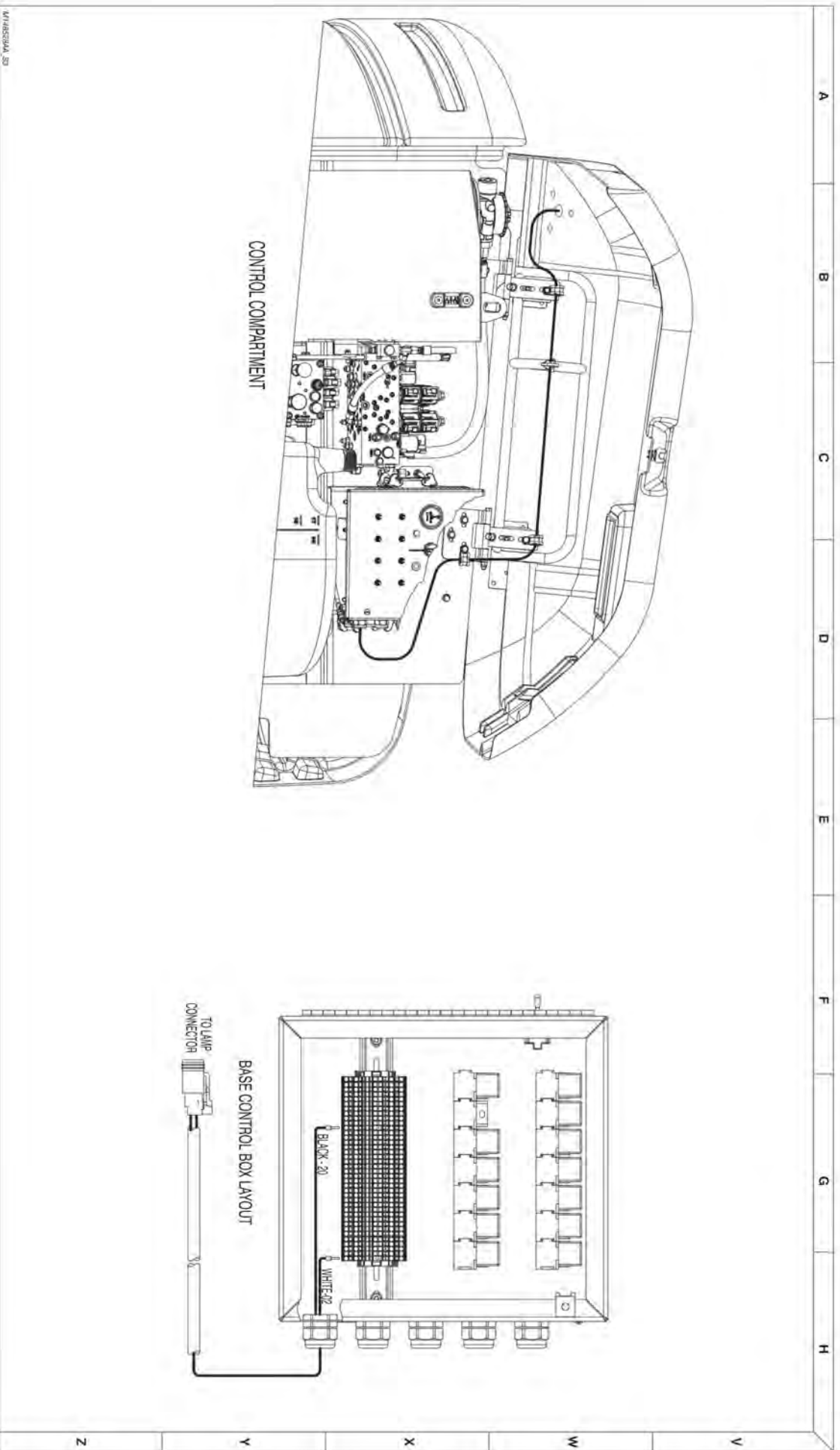

MTAFCBAA_3D

2302714A04

80

3.28 Positive Air Shut-off Harness - Kubota D1305

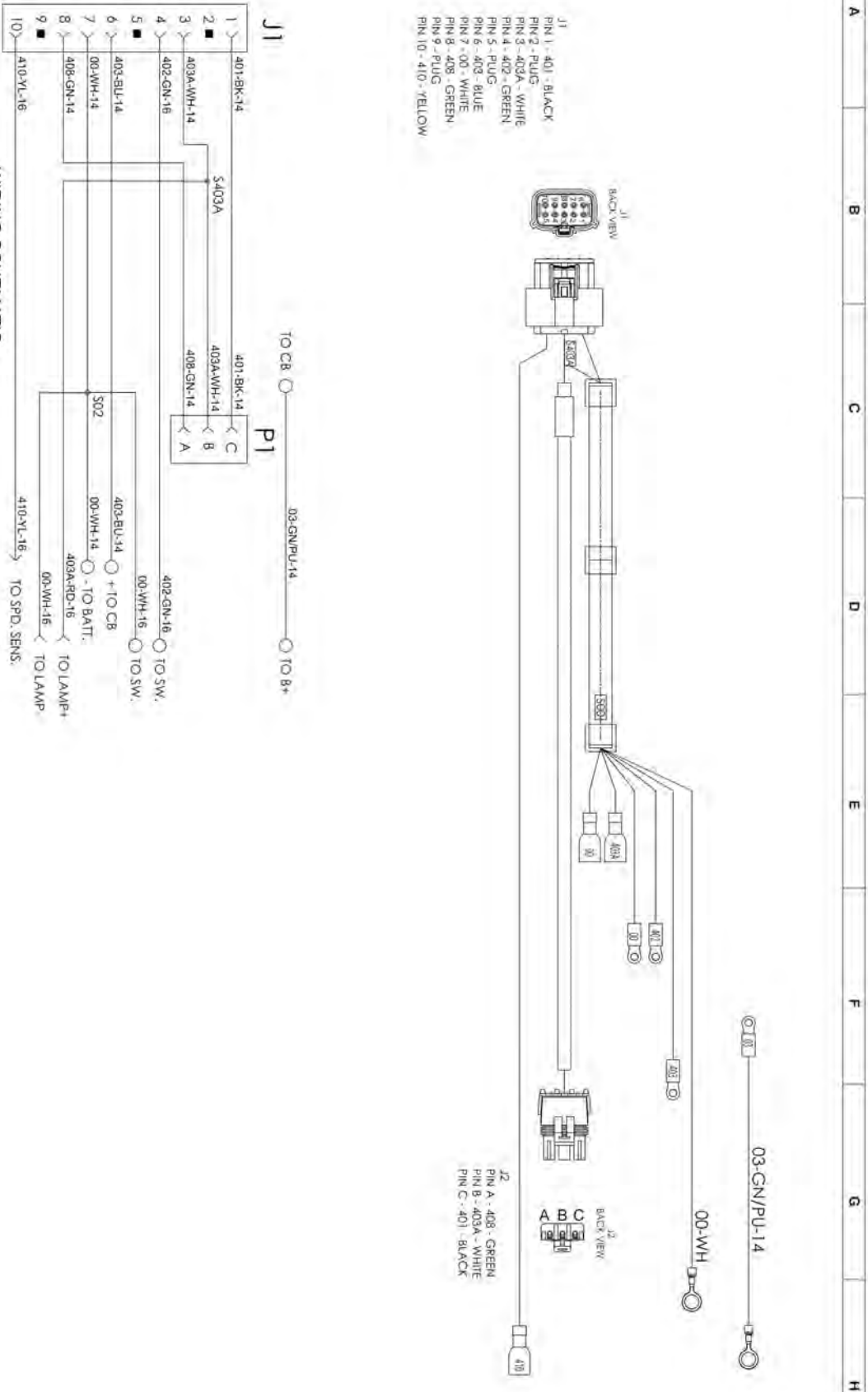

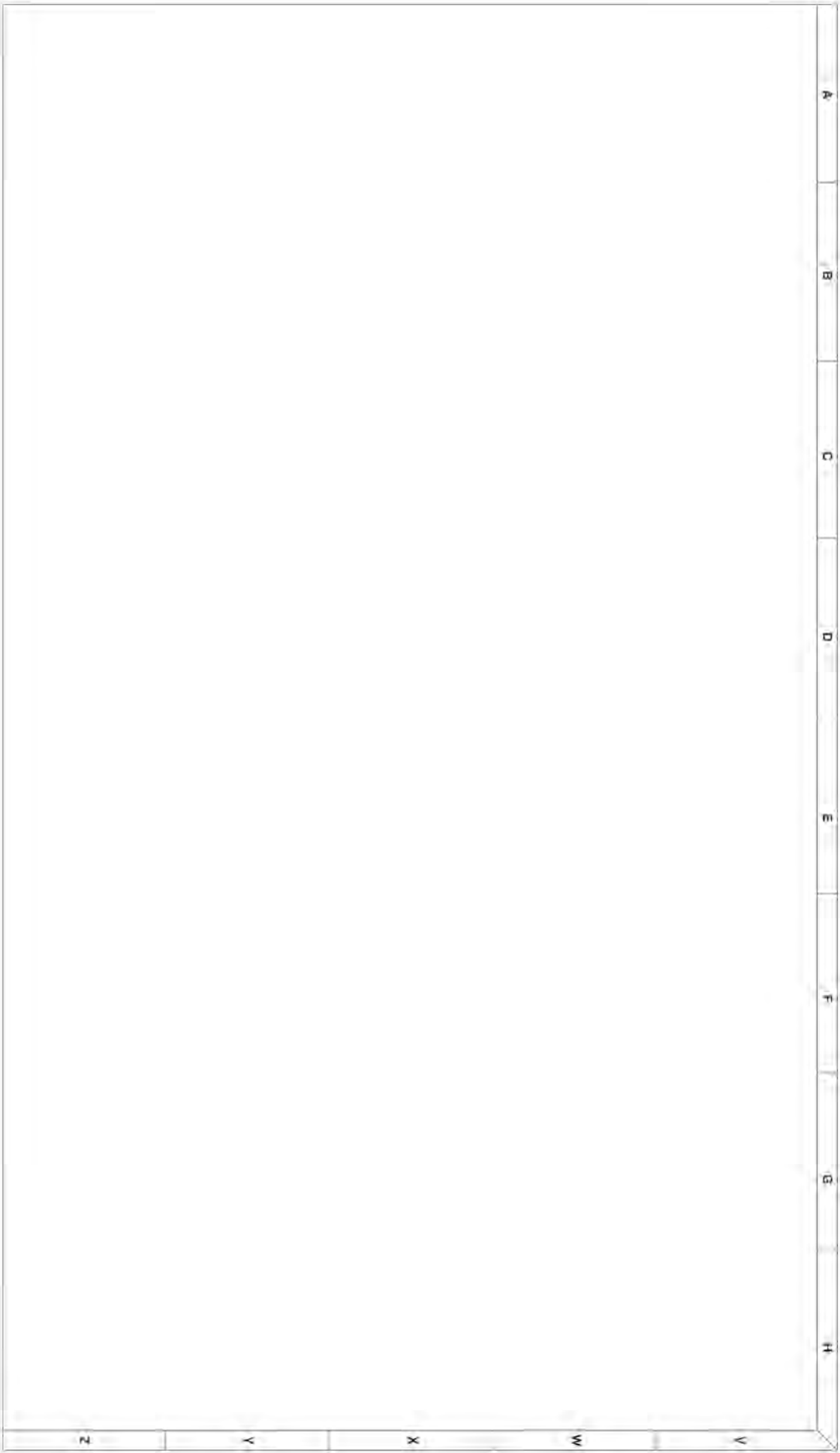

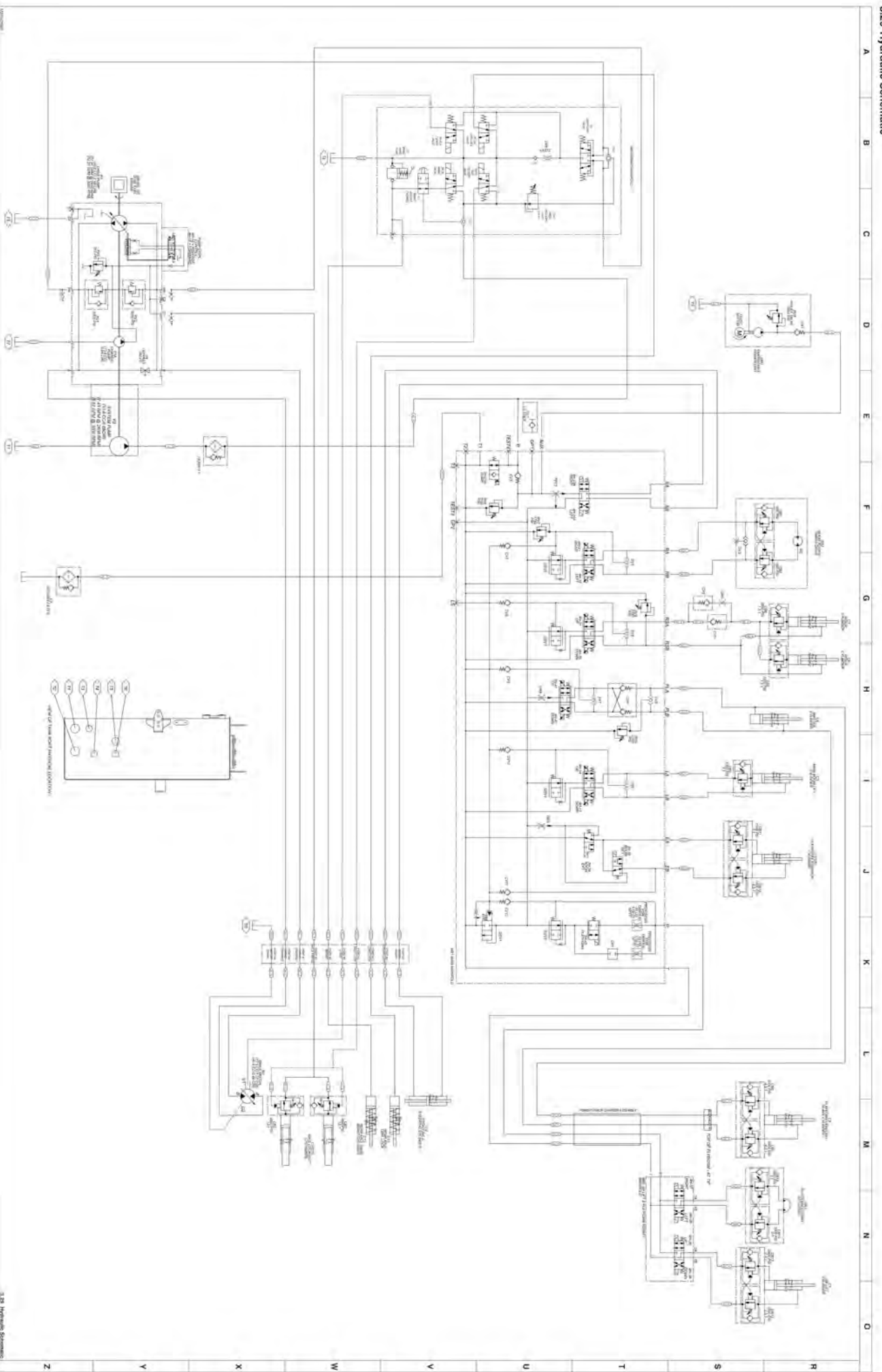

Wire Number and Colour Chart

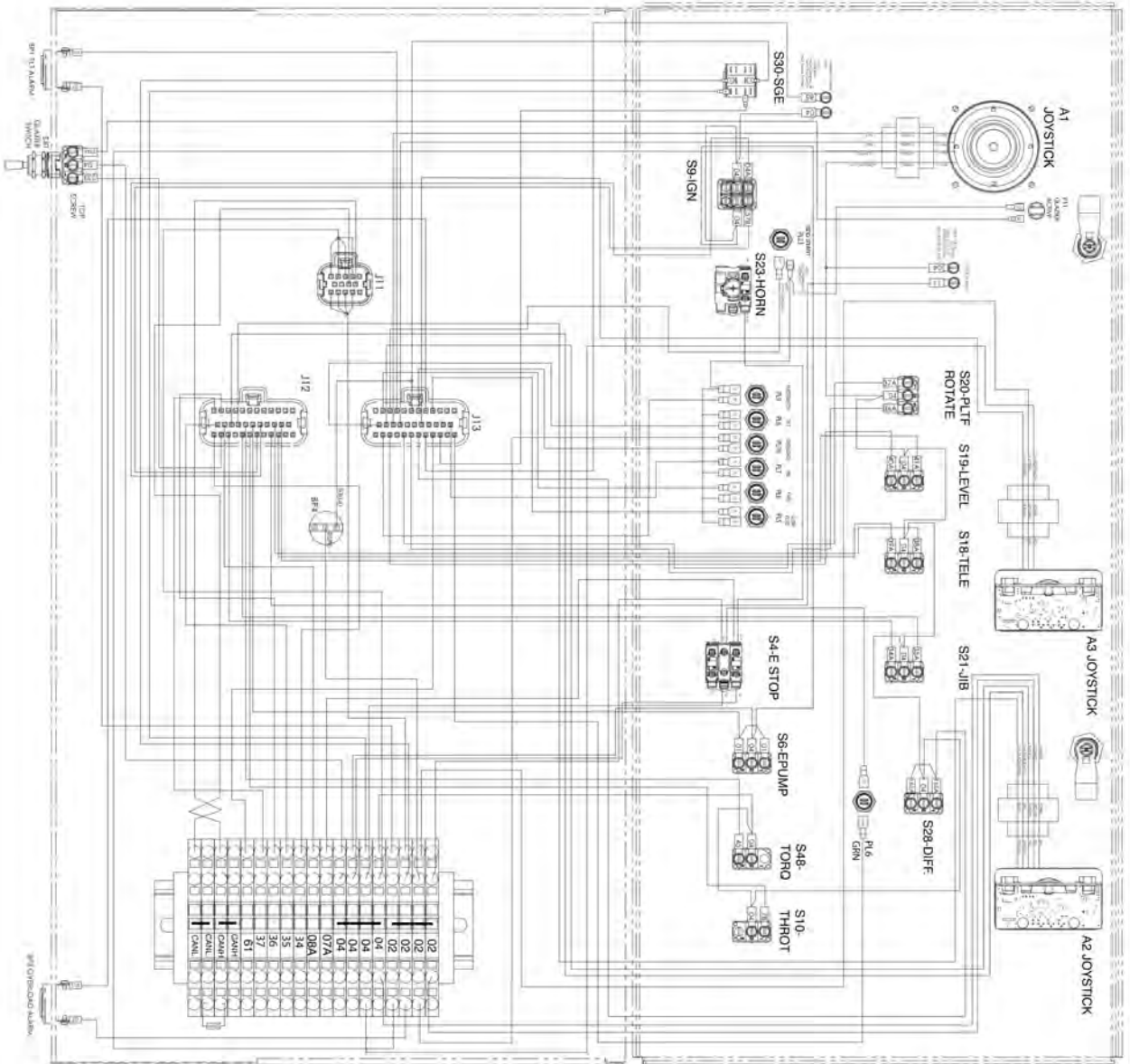

Wire No.	Colour	Terminal	Component
W1	Red	02	STOP
W2	Blue	03	STOP
W3	Green	04	STOP
W4	Yellow	05	STOP
W5	Purple	06	STOP
W6	Brown	07	STOP
W7	Pink	08	STOP
W8	Grey	09	STOP
W9	Black	10	STOP
W10	White	11	STOP
W11	Light Blue	12	STOP
W12	Light Green	13	STOP
W13	Light Yellow	14	STOP
W14	Light Purple	15	STOP
W15	Light Brown	16	STOP
W16	Light Pink	17	STOP
W17	Light Grey	18	STOP
W18	Light Black	19	STOP
W19	Light White	20	STOP
W20	Light Red	21	STOP
W21	Light Blue	22	STOP
W22	Light Green	23	STOP
W23	Light Yellow	24	STOP
W24	Light Purple	25	STOP
W25	Light Brown	26	STOP
W26	Light Pink	27	STOP
W27	Light Grey	28	STOP
W28	Light Black	29	STOP
W29	Light White	30	STOP
W30	Light Red	31	STOP
W31	Light Blue	32	STOP
W32	Light Green	33	STOP
W33	Light Yellow	34	STOP
W34	Light Purple	35	STOP
W35	Light Brown	36	STOP
W36	Light Pink	37	STOP
W37	Light Grey	38	STOP
W38	Light Black	39	STOP
W39	Light White	40	STOP
W40	Light Red	41	STOP
W41	Light Blue	42	STOP
W42	Light Green	43	STOP
W43	Light Yellow	44	STOP
W44	Light Purple	45	STOP
W45	Light Brown	46	STOP
W46	Light Pink	47	STOP
W47	Light Grey	48	STOP
W48	Light Black	49	STOP
W49	Light White	50	STOP
W50	Light Red	51	STOP
W51	Light Blue	52	STOP
W52	Light Green	53	STOP
W53	Light Yellow	54	STOP
W54	Light Purple	55	STOP
W55	Light Brown	56	STOP
W56	Light Pink	57	STOP
W57	Light Grey	58	STOP
W58	Light Black	59	STOP
W59	Light White	60	STOP
W60	Light Red	61	STOP
W61	Light Blue	62	STOP
W62	Light Green	63	STOP
W63	Light Yellow	64	STOP
W64	Light Purple	65	STOP
W65	Light Brown	66	STOP
W66	Light Pink	67	STOP
W67	Light Grey	68	STOP
W68	Light Black	69	STOP
W69	Light White	70	STOP
W70	Light Red	71	STOP
W71	Light Blue	72	STOP
W72	Light Green	73	STOP
W73	Light Yellow	74	STOP
W74	Light Purple	75	STOP
W75	Light Brown	76	STOP
W76	Light Pink	77	STOP
W77	Light Grey	78	STOP
W78	Light Black	79	STOP
W79	Light White	80	STOP
W80	Light Red	81	STOP
W81	Light Blue	82	STOP
W82	Light Green	83	STOP
W83	Light Yellow	84	STOP
W84	Light Purple	85	STOP
W85	Light Brown	86	STOP
W86	Light Pink	87	STOP
W87	Light Grey	88	STOP
W88	Light Black	89	STOP
W89	Light White	90	STOP
W90	Light Red	91	STOP
W91	Light Blue	92	STOP
W92	Light Green	93	STOP
W93	Light Yellow	94	STOP
W94	Light Purple	95	STOP
W95	Light Brown	96	STOP
W96	Light Pink	97	STOP
W97	Light Grey	98	STOP
W98	Light Black	99	STOP
W99	Light White	100	STOP

Wire Number and Colour Chart

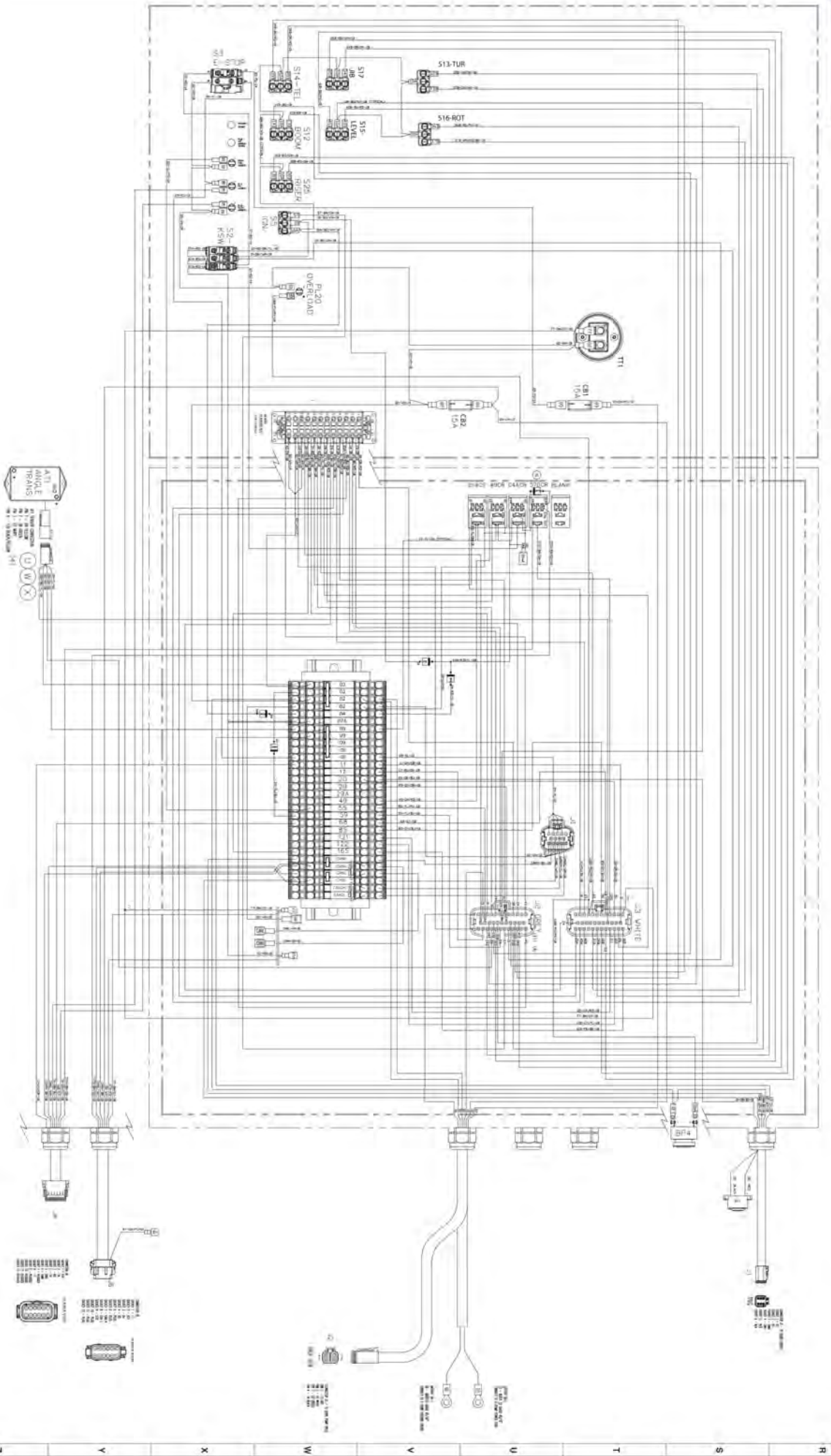

3.31 Base Control Box Wiring - ANSI/CSA & AS

Wire Number and Colour Chart

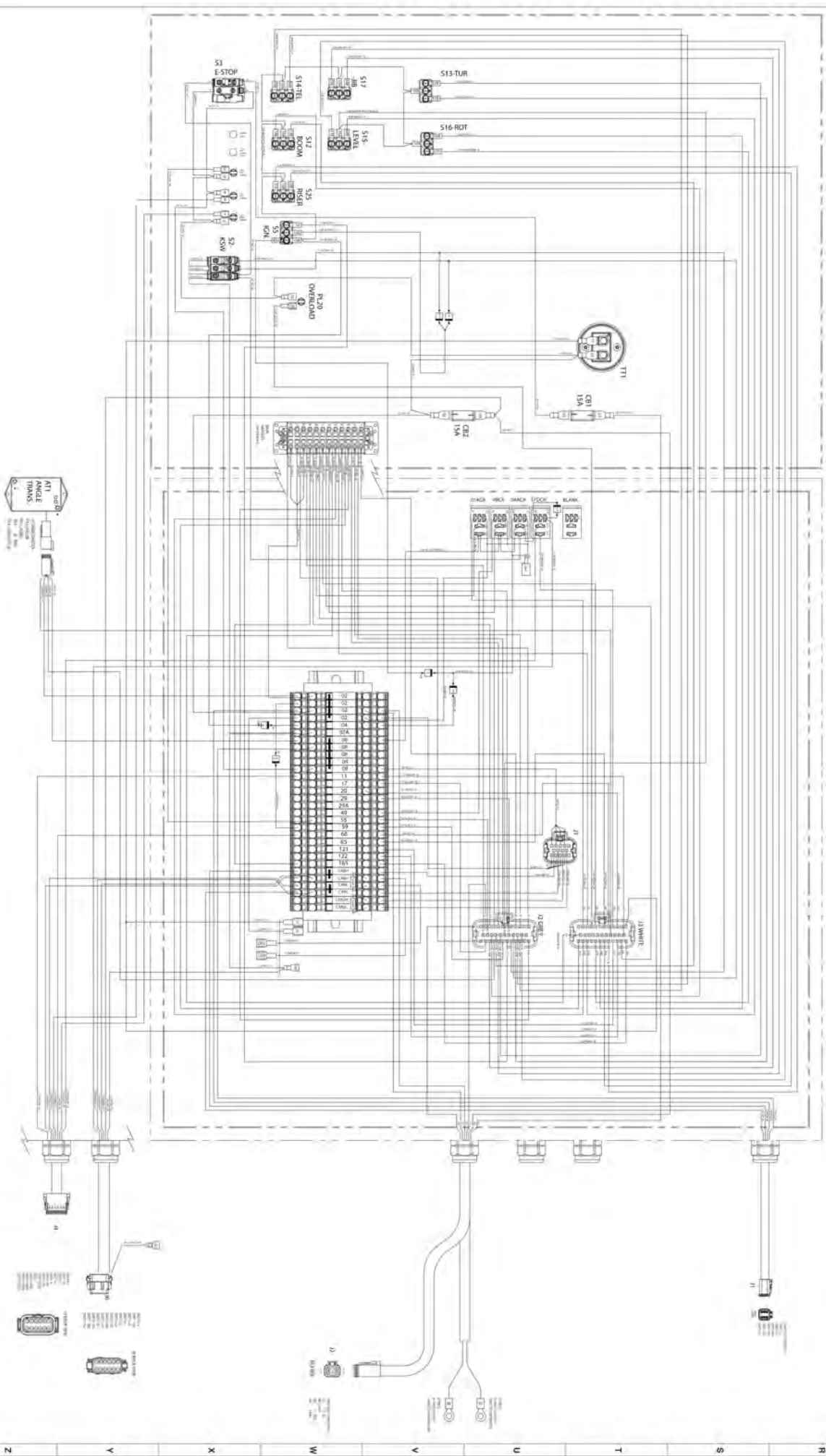

132 Base Control Box Wiring - CE

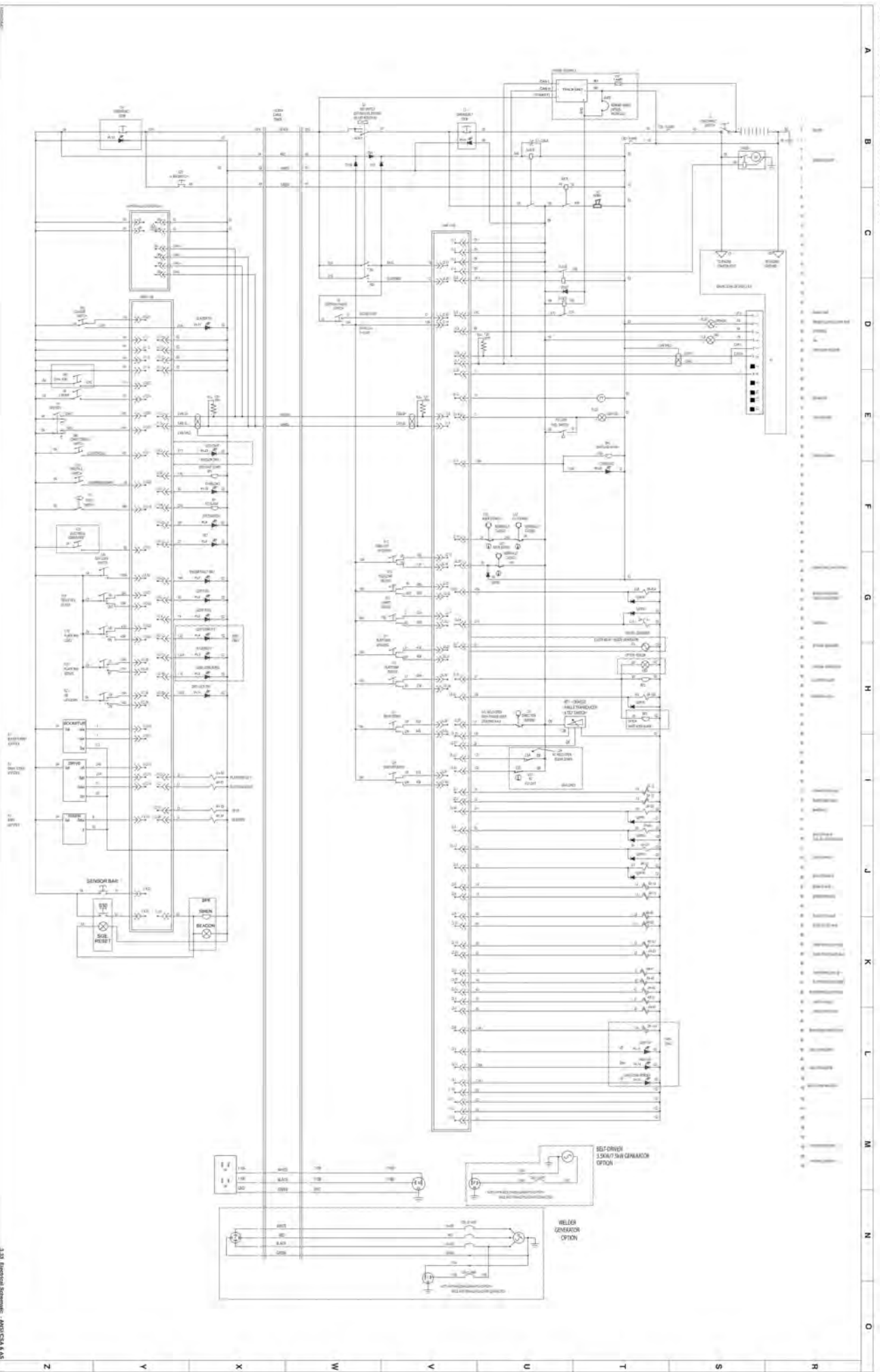

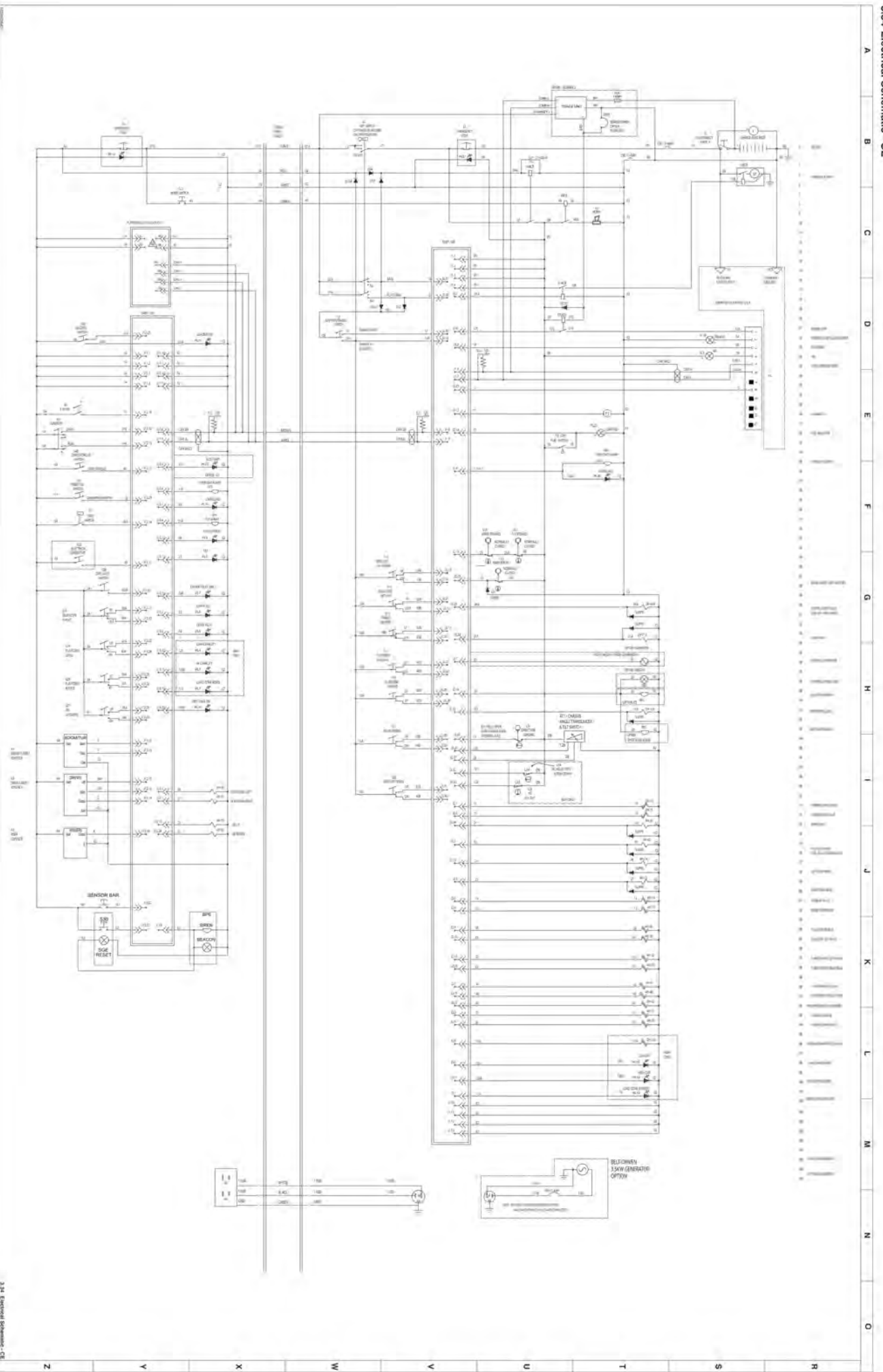

A B C D E F G H I J K L M N O Z

DIESEL ENGINE

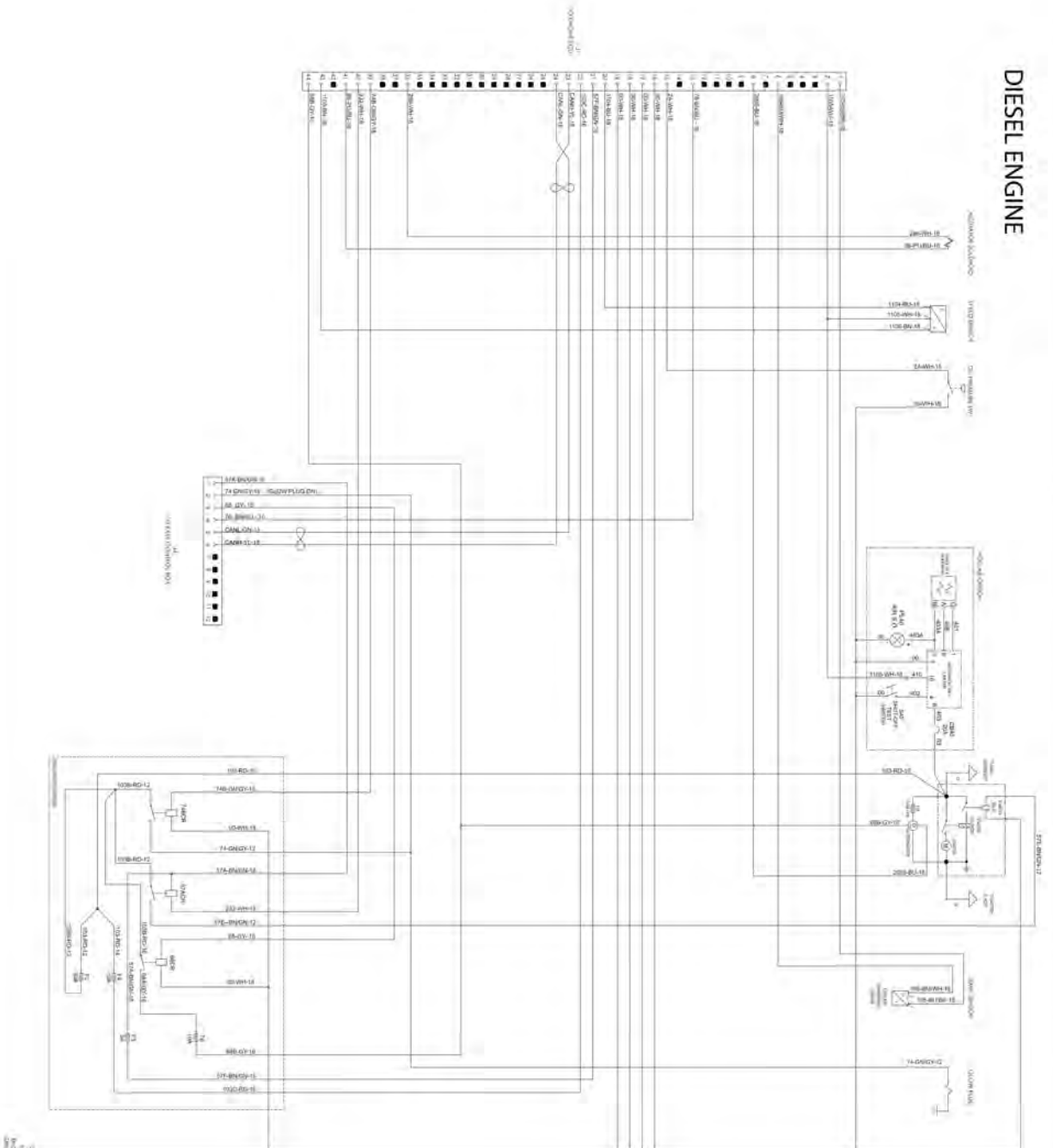

DUAL FUEL ENGINE

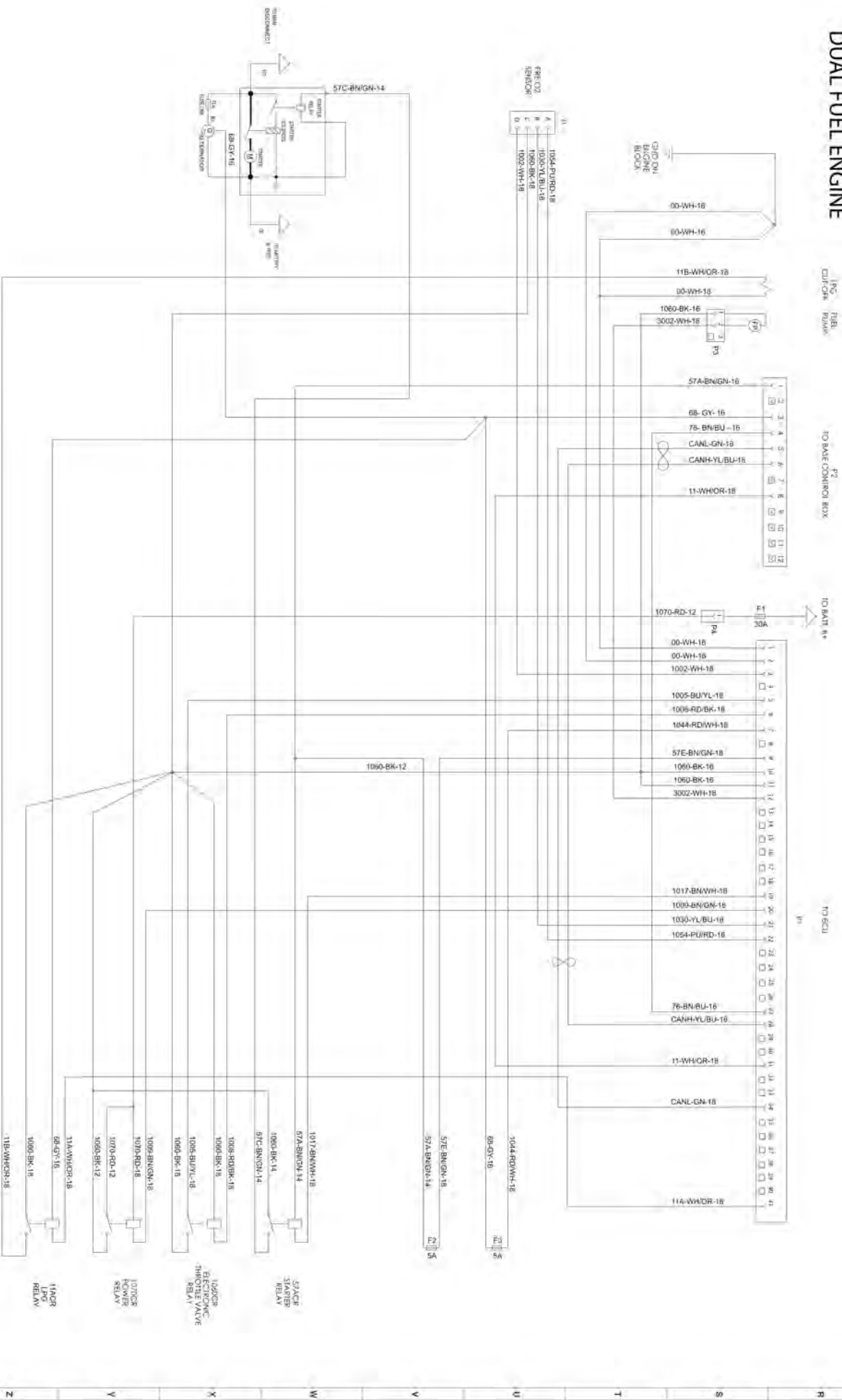

3.36 Engine Schematic - Kubota WG972

Section 4 – Troubleshooting Information

4.1 Introduction

The following pages contain a table of Troubleshooting for locating and correcting most service trouble which can develop. Careful and accurate analysis of the systems listed in the table of Troubleshooting will localize the trouble more quickly than any other method. This manual cannot cover all possible troubles and deficiencies that may occur. If a specific trouble is not listed, isolate the major component in which the trouble occurs, isolate whether the problem is electrical or hydraulic, and then isolate and correct the specific problem.

The content of this section is separated into "probable cause" and "remedy." The information in the left-hand column, preceded by a number, represents the "probable cause." The information in the right-hand column, in bold text, represents the "remedy" to the "probable cause" directly beside it. See the example below for clarification.

1. Probable cause

Remedy

4.2 Electrical System

4.2-1 All Controls are Inoperative from the Base or Platform Console



NOTE

Functions may be disabled by the dual load zone system or the overload system. Please first make sure the boom is at or below level and fully retracted, the platform is level and free of added weight, and there are no faults in the dual load or overload systems.

1. Battery cables loose/disconnected	Tighten or connect battery cables
2. Battery Discharged or Defective	Charge battery or replace if defective
3. Loose or broken B+ cable from batteries to battery disconnect switch S1	Check continuity. Replace if defective.
4. Open or defective battery disconnect switch S1	Close switch. Replace if defective
5. Loose or broken wire #03 from battery disconnect switch S1 to circuit breaker CB1	Check continuity. Replace if defective
6. Circuit breaker CB1 tripped or defective.	Reset breaker, check for defective wiring. Replace if defective.
7. Loose or broken wire #05 from circuit breaker CB1 to base emergency stop switch S3.	Check continuity. Replace if defective.
8. Open or defective base emergency stop switch S3.	Close switch. Replace if defective.
9. Loose or broken wire #07 from base emergency stop switch S3 to base key switch S2.	Check continuity. Replace if defective.
10. Loose or broken #07A wires between base key switch S2 terminals	Check continuity. Replace if defective.
11. Open or defective key select switch S2	Close switch. Replace if defective
12. Loose or broken wire #04A from base terminal block to relay 04ACR.	Check continuity. Replace if defective.
13. Loose or broken wire #07 from base emergency stop switch S3 to relay 04ACR.	Check continuity. Replace if defective.
14. Loose or broken wire #02 from relay 04ACR to base terminal block.	Check continuity. Replace if defective.
15. Defective relay 04ACR.	Check relay. Replace if defective.
16. Loose or broken wire #09 from relay 04ACR to base terminal block.	Check continuity. Replace if defective.

17. Loose or broken wire #09 from base terminal block to base control module connector J1 pins 1, 2, 3, and/or 4.	Check continuity. Replace if defective.
18. Loose or broken wire #02 from base control module connector J1 pins 10, 11, 12, and/or 13 to base terminal block.	Check continuity. Replace if defective.
19. Loose or broken wire #02 from base terminal block to circuit breaker CB2.	Check continuity. Replace if defective.
20. Circuit breaker CB2 tripped or defective.	Reset breaker, check for defective wiring. Replace if defective.
21. Loose or broken wire #00 from circuit breaker CB2 to battery negative.	Check continuity. Replace if defective.
22. Loose or broken wire #07A from base key switch S2 to base terminal block.	Check continuity. Replace if defective.
23. Loose or broken wire #07A from base terminal block to platform terminal block.	Check continuity. Replace if defective.
24. Loose or broken wire #07A from platform terminal block to platform emergency stop switch S4.	Check continuity. Replace if defective.
25. Open or defective platform emergency stop switch S4.	Close switch. Replace if defective.
26. Loose or broken wire #04 from platform emergency stop switch S4 to platform terminal block.	Check continuity. Replace if defective.
27. Loose or broken wire #04 from platform terminal block platform control module connector J11 pins 1, 2, 3, and/or 4.	Check continuity. Replace if defective.
28. Loose or broken CAN H wire from platform control module connector J11 pin 8 to platform terminal block	Check continuity. Replace if defective.
29. Loose or broken CAN H wire from platform terminal block to base terminal block.	Check continuity. Replace if defective.
30. Loose or broken CAN H wire from base terminal block to base control module connector J1 pin 8.	Check continuity. Replace if defective.
31. Loose or broken CAN L wire from platform control module connector J11 pin 9 to platform terminal block	Check continuity. Replace if defective.
32. Loose or broken CAN L wire from platform terminal block to base terminal block.	Check continuity. Replace if defective.
33. Loose or broken CAN L wire from base terminal block to base control module connector J1 pin 9.	Check continuity. Replace if defective.

34. Loose, broken, or defective 120 ohm CAN termination resistor(s) between CAN H and CAN L terminals in platform and/or base terminal block(s).	Check that resistance between CAN H and CAN L is approximately 60 ohms (2 x 120 ohm in parallel). Check connections. Repair connections or replace if defective.
35. Loose or broken wire #02 from platform control module connector J11 pins 10, 11, 12, and/or 13 to platform terminal block.	Check continuity. Replace if defective.
36. Loose or broken wire #02 from platform terminal block to base terminal block.	Check continuity. Replace if defective.
37. Defective base (master) control module SMB1-105	Replace if Defective
38. Defective platform (slave) control module SMB1-106	Replace if Defective

4.2-2 All Controls are Inoperative from the Base Console

1. loose or defective wire #10 from keyswitch S2 to ignition/enable switch S5	Check continuity. Replace if defective
2. Defective ignition/enable switch S5	Check continuity through switch when activated. Replace if defective
3. Loose or broken wire #10A from ignition/enable switch S5 to base control module connector J2 pin 18.	Check continuity. Replace if defective
4. Loose or broken wire #10A from ignition/enable switch S5 to base boom control toggle switches.	Check continuity. Replace if defective

4.2-3 The Engine will not Crank from the Base or Platform

1. Loose or broken wire #57C from base control module connector J3 pin 9 to 57DCR relay pin 30.	Check continuity. Replace if defective
2. Loose or broken wire #09 from base terminal block to 57DCR relay pin 85	Check continuity. Replace if defective
3. Loose or broken wire #57D from 57DCR relay pin 86 to telematics connector J6 pin 9	Check continuity. Replace if defective
4. Loose or broken jumper wire from J6 pin 9 to J6 pin 4, or if equipped with telematics then either start interlock is engaged or telematics are inoperative	Check continuity of jumper. Check telematics if equipped. Repair or replace as required.
5. Loose or broken wire #00 from J6 pin 4 to ground.	Check continuity. Replace if defective
6. Loose or broken wire #57A from relay 57DCR pin 87 to connector J4 pin 8.	Check continuity. Replace if defective

- | | |
|---|---|
| 7. Defective relay 57DCR. | Check relay. Replace if defective. |
| 8. Loose or broken 57A wire from connector P4 pin 8 to start input on ECU or 57ACR relay if equipped. | Check schematic applicable to the engine equipped on the machine to determine ECU pin # or relay if equipped. |

**NOTE**

For other engine-related problems, consult the engine manufacturer's manual.

4.2-4 The Engine will not Crank from the Base

- | | |
|---|---|
| 1. Loose or broken wire #10 from base keyswitch S2 to base start switch S5 | Check continuity. Replace if defective |
| 2. Loose or broken wire #57 from base start switch S5 to base control module connector J2 pin 30. | Check continuity. Replace if defective |
| 3. Defective start/enable switch S5 | Check continuity through switch. Replace if defective |

4.2-5 The Engine will not Crank from the Platform

**NOTE**

The engine will not crank from the platform with the footswitch pressed.

- | | |
|---|---|
| 1. Loose or broken wire #04 from platform terminal block to start switch S9. | Check continuity. Replace if defective |
| 2. Loose or broken wire #57B from start switch S9 to platform control module connector J12 pin 30 | Check continuity. Replace if defective |
| 3. Defective start switch S9 | Check continuity through switch. Replace if defective |

4.2-6 The Boom Controls are Inoperative (Drive Operates)

- | | |
|--|--|
| 1. Loose or broken wire #21A from base control module connector J3 pin 24 to main harness 24 pin connector pin 3 | Check continuity. Replace if defective |
| 2. Loose or broken wire #21A from main harness plug pin #3 to dump valve 2H-21A | Check continuity. Replace if defective |
| 3. Loose or broken wire #02 from dump valve 2H-21A to main harness plug | Check continuity. Replace if defective |
| 4. Defective dump valve coil 2H-21A | Check continuity and resistance through coil. Replace if defective |

4.2-7 No Boom Up from the Base or Platform Controls

1. Loose or broken wire #14 from base control module connector J2 pin 5 base terminal block to turret harness plug pin #2	Check continuity. Replace if defective
2. Loose or broken wire #14 from turret harness plug pin #2 to boom up valve 4H-14	Check continuity. Replace if defective
3. Loose or broken wire #02 from turret harness plug to boom up valve 4H-14	Check continuity. Replace if defective
4. Defective boom up coil 4H-14	Check continuity and resistance through coil. Replace if defective

4.2-8 No Boom Up from the Base Console

1. Loose or broken wire #10A from IGN switch S5 to boom switch S12	Check continuity. Replace if defective
2. Defective boom switch S12	Check continuity through switch while activating boom up function between wires #10A and #14B. Replace switch if no continuity
3. Loose or broken wire #14B from boom switch S12 to base control module connector J2 pin 15	Check continuity. Replace if defective

4.2-9 No Boom Up from the Platform Console

1. Loose or broken wire #04 from platform terminal block to joystick controller A1	Check continuity. Replace if defective
2. Loose or broken wire #02 from platform terminal block to joystick controller A1	Check continuity. Replace if defective
3. No output on y-axis of joystick controller A1	Refer to joystick test procedure in section 5
4. Loose or broken wire "Y" from joystick controller to J13 pin #16 of platform control module	Check continuity. Replace if defective

4.2-10 No Boom Down from the Base or Platform Consoles

1. Loose or broken wire #13 from base control module connector J2 pin 6 base terminal block to turret harness plug pin #1	Check continuity. Replace if defective
2. Loose or broken wire #13 from turret harness plug pin #1 to boom down valve 4H-13	Check continuity. Replace if defective
3. Loose or broken wire #02 from turret harness plug to boom down valve 4H-13	Check continuity. Replace if defective
4. Defective boom down coil 4H-13	Check continuity and resistance through coil. Replace if defective

4.2-11 No Boom Down from the Base Console

- | | |
|--|--|
| 1. Loose or broken wire #10A from IGN switch S5 to boom switch S12 | Check continuity. Replace if defective |
| 2. Defective boom switch S12 | Check continuity through switch while activating boom down function between wires #10A and #13B. Replace switch if no continuity |
| 3. Loose or broken wire #13B from boom switch S12 to base control module connector J2 pin 16 | Check continuity. Replace if defective |

4.2-12 No Boom Down from the Platform Console

- | | |
|--|---|
| 1. Loose or broken wire #04 from platform terminal block to joystick controller A1 | Check continuity. Replace if defective |
| 2. Loose or broken wire #02 from platform terminal block to joystick controller A1 | Check continuity. Replace if defective |
| 3. No output on y-axis of joystick controller A1 | Refer to joystick test procedure in section 5 |
| 4. Loose or broken wire "Y" from joystick controller to J13 pin #15 of platform control module | Check continuity. Replace if defective |

4.2-13 No Turret Rotate Right from the Base or Platform Consoles

- | | |
|---|--|
| 1. Loose or broken wire #33 from base control module connector J2 pin 24 base terminal block to turret harness plug pin #10 | Check continuity. Replace if defective |
| 2. Loose or broken wire #33 from turret harness plug pin #10 to boom up valve 4H-33 | Check continuity. Replace if defective |
| 3. Loose or broken wire #02 from turret harness plug to boom up valve 4H-33 | Check continuity. Replace if defective |
| 4. Defective boom up coil 4H-33 | Check continuity and resistance through coil. Replace if defective |

4.2-14 No Turret Rotate Right from the Base Console

- | | |
|--|--|
| 1. Loose or broken wire #10A from IGN switch S5 to turret rotate switch S13 | Check continuity. Replace if defective |
| 2. Defective turret rotate switch S13 | Check continuity through switch while activating turret rotate right function between wires #10A and #33B. Replace switch if no continuity |
| 3. Loose or broken wire #33B from boom switch S12 to base control module connector J2 pin 32 | Check continuity. Replace if defective |

4.2-15 No Turret Rotate Right from the Platform Console

1. Loose or broken wire #04 from platform terminal block to joystick controller A1	Check continuity. Replace if defective
2. Loose or broken wire #02 from platform terminal block to joystick controller A1	Check continuity. Replace if defective
3. No output on X-axis of joystick controller A1	Refer to joystick test procedure in section 5
4. Loose or broken wire "x" from joystick controller to J13 pin #16 of platform control module	Check continuity. Replace if defective

4.2-16 No Turret Rotate Left from the Base or Platform Consoles

1. Loose or broken wire #32 from base control module connector J2 pin 13 to turret harness plug pin #9	Check continuity. Replace if defective
2. Loose or broken wire #32 from turret harness plug pin #9 to turret rotate left valve 4H-32	Check continuity. Replace if defective
3. Loose or broken wire #02 from turret harness plug to turret rotate left valve 4H-32	Check continuity. Replace if defective
4. Defective turret rotate left coil 4H-32	Check continuity and resistance through coil. Replace if defective

4.2-17 No Turret Rotate Left from the Base Console

1. Loose or broken wire #10A from IGN switch S5 to turret rotate switch S13	Check continuity. Replace if defective
2. Defective turret rotate switch S13	Check continuity through switch while activating down function between wires #10A and #32B. Replace switch if no continuity
3. Loose or broken wire #32B from turret rotate switch S13 to base control module connector J2 pin 17	Check continuity. Replace if defective

4.2-18 No Turret Rotate Left from the Platform Console

1. Loose or broken wire #04 from platform terminal block to joystick controller A1	Check continuity. Replace if defective
2. Loose or broken wire #02 from platform terminal block to joystick controller A1	Check continuity. Replace if defective
3. No output on y-axis of joystick controller A1	Refer to joystick test procedure in section 5
4. Loose or broken wire "Y" from joystick controller to J13 pin #16 of platform control module	Check continuity. Replace if defective

4.2-19 No Riser Up from the Base or Platform Consoles

- | | |
|---|--|
| 1. Loose or broken wire #31 from base control module connector J2 pin 3 to turret harness plug pin #8 | Check continuity. Replace if defective |
| 2. Loose or broken wire #31 from turret harness plug pin #8 to riser up valve 4H-31 | Check continuity. Replace if defective |
| 3. Loose or broken wire #02 from turret harness plug to riser up valve 4H-31 | Check continuity. Replace if defective |
| 4. Defective rise up coil 4H-31 | Check continuity and resistance through coil. Replace if defective |

4.2-20 No Riser Up from the Base Console

- | | |
|---|---|
| 1. Loose or broken wire #10A from IGN switch S5 to boom switch S25 | Check continuity. Replace if defective |
| 2. Defective riser switch S25 | Check continuity through switch while activating riser up function between wires #10A and #31B. Replace switch if no continuity |
| 3. Loose or broken wire #31B from riser switch S25 to base control module connector J3 pin 31 | Check continuity. Replace if defective |

4.2-21 No Riser Up from the Platform Console

- | | |
|--|---|
| 1. Loose or broken wire #04 from platform terminal block to joystick controller A3 | Check continuity. Replace if defective |
| 2. Loose or broken wire #02 from platform terminal block to joystick controller A3 | Check continuity. Replace if defective |
| 3. No output on "R" of joystick controller A3 | Refer to joystick test procedure in section 5 |
| 4. Loose or broken wire "R" from joystick controller to J13 pin #19 of platform control module | Check continuity. Replace if defective |

4.2-22 No Riser Down from the Base or Platform Consoles

- | | |
|---|--|
| 1. Loose or broken wire #30 from base control module connector J2 pin 4 to turret harness plug pin #7 | Check continuity. Replace if defective |
| 2. Loose or broken wire #30 from turret harness plug pin #7 to riser down valve 4H-30 | Check continuity. Replace if defective |
| 3. Loose or broken wire #02 from turret harness plug to riser down valve 4H-30 | Check continuity. Replace if defective |
| 4. Defective rise down coil 4H-30 | Check continuity and resistance through coil. Replace if defective |

4.2-23 No Riser Down from the Base Console

- | | |
|---|---|
| 1. Loose or broken wire #10A from IGN switch S5 to boom switch S25 | Check continuity. Replace if defective |
| 2. Defective riser switch S25 | Check continuity through switch while activating riser down function between wires #10A and #30B. Replace switch if no continuity |
| 3. Loose or broken wire #30B from riser switch S25 to base control module connector J3 pin 30 | Check continuity. Replace if defective |

4.2-24 No Riser Down from the Platform Console

- | | |
|--|---|
| 1. Loose or broken wire #04 from platform terminal block to joystick controller A3 | Check continuity. Replace if defective |
| 2. Loose or broken wire #02 from platform terminal block to joystick controller A3 | Check continuity. Replace if defective |
| 3. No output on "R" of joystick controller A3 | Refer to joystick test procedure in section 5 |
| 4. Loose or broken wire "R" from joystick controller to J13 pin #19 of platform control module | Check continuity. Replace if defective |

4.2-25 No Telescope Out from the Base or Platform Consoles

- | | |
|---|--|
| 1. Loose or broken wire #39 from base control module connector J2 pin 10 to turret harness plug pin #14 | Check continuity. Replace if defective |
| 2. Loose or broken wire #39 from turret harness plug pin #14 to telescope out valve 4H-39 | Check continuity. Replace if defective |
| 3. Loose or broken wire #02 from turret harness plug to boom up valve 4H-39 | Check continuity. Replace if defective |
| 4. Defective telescope out coil 4H-39 | Check continuity and resistance through coil. Replace if defective |

4.2-26 No Telescope Out from the Base Console

- | | |
|---|--|
| 1. Loose or broken wire #10A from IGN switch S5 to telescope switch S13 | Check continuity. Replace if defective |
| 2. Defective boom switch S13 | Check continuity through switch while activating telescope out function between wires #10A and #39B. Replace switch if no continuity |
| 3. Loose or broken wire #39B from telescope switch S13 to base control module connector J2 pin 33 | Check continuity. Replace if defective |

4.2-27 No Telescope Out from the Platform Console

- | | |
|--|---|
| 1. Loose or broken wire #04 from platform terminal block to telescope switch S18 | Check continuity. Replace if defective |
| 2. Defective boom switch S18 | Check continuity through switch while activating telescope out function between wires #04 and #39A. Replace switch if no continuity |
| 3. Loose or broken wire #39A from telescope switch S18 to platform control module connector J12 pin 33 | Check continuity. Replace if defective |

4.2-28 No Telescope In from the Base or Platform Consoles

- | | |
|--|--|
| 1. Loose or broken wire #38 from base control module connector J2 pin 9 to turret harness plug pin #13 | Check continuity. Replace if defective |
| 2. Loose or broken wire #38 from turret harness plug pin #13 to telescope in valve 4H-38 | Check continuity. Replace if defective |
| 3. Loose or broken wire #02 from turret harness plug to telescope in valve 4H-38 | Check continuity. Replace if defective |
| 4. Defective telescope in coil 4H-38 | Check continuity and resistance through coil. Replace if defective |

4.2-29 No Telescope In from the Base Console

- | | |
|--|---|
| 1. Loose or broken wire #10A from IGN switch S5 to telescope switch S14 | Check continuity. Replace if defective |
| 2. Defective telescope switch S14 | Check continuity through switch while activating telescope in function between wires #10A and #38B. Replace switch if no continuity |
| 3. Loose or broken wire #38B from boom switch S14 to base control module connector J2 pin 21 | Check continuity. Replace if defective |

4.2-30 No Telescope In from the Platform Console

- | | |
|---|--|
| 1. Loose or broken wire #04 from platform terminal block to telescope switch S18 | Check continuity. Replace if defective |
| 2. Defective telescope switch S18 | Check continuity through switch while activating down function between wires #04 and #38A. Replace switch if no continuity |
| 3. Loose or broken wire #38A from boom switch S18 to platform control module connector J12 pin 21 | Check continuity. Replace if defective |

4.2-31 No Platform Level Up from the Base or Platform Consoles

- | | |
|---|--|
| 1. Loose or broken wire #41 from base control module connector J2 pin #7 to turret harness plug pin #16 | Check continuity. Replace if defective |
| 2. Loose or broken wire #41 from turret harness plug pin #16 to platform level up valve 4H-41 | Check continuity. Replace if defective |
| 3. Loose or broken wire #02 from turret harness plug to platform level up valve 4H-41 | Check continuity. Replace if defective |
| 4. Defective platform level up coil 4H-41 | Check continuity and resistance through coil. Replace if defective |

4.2-32 No Platform Level Up from the Base Console

- | | |
|--|---|
| 1. Loose or broken wire #10A from IGN switch S5 to platform level switch S15 | Check continuity. Replace if defective |
| 2. Defective platform level switch S15 | Check continuity through switch while activating up function between wires #10A and #41B. Replace switch if no continuity |
| 3. Loose or broken wire #41B from platform level switch S15 to base control module connector J2 pin 22 | Check continuity. Replace if defective |

4.2-33 No Platform Level Up from the Platform Console

- | | |
|---|---|
| 1. Loose or broken wire #04 from platform terminal block to platform level switch S19 | Check continuity. Replace if defective |
| 2. Defective platform level switch S19 | Check continuity through switch while activating platform level up function between wires #04 and #41A. Replace switch if no continuity |
| 3. Loose or broken wire #41A from platform level switch S19 to platform control module connector J12 pin 22 | Check continuity. Replace if defective |

4.2-34 No Platform Level Down from the Base or Platform Consoles

- | | |
|---|--|
| 1. Loose or broken wire #40 from base control module connector J2 pin 35 to turret harness plug pin #15 | Check continuity. Replace if defective |
| 2. Loose or broken wire #40 from turret harness plug pin #15 to platform level down valve 4H-40 | Check continuity. Replace if defective |
| 3. Loose or broken wire #02 from turret harness plug to platform level down valve 4H-40 | Check continuity. Replace if defective |
| 4. Defective platform level down coil 4H-40 | Check continuity and resistance through coil. Replace if defective |

4.2-35 No Platform Level Down from the Base Console

- | | |
|--|--|
| 1. Loose or broken wire #10A from IGN switch S5 to platform level switch S16 | Check continuity. Replace if defective |
| 2. Defective platform level switch S16 | Check continuity through switch while activating platform level down function between wires #10A and #40B. Replace switch if no continuity |
| 3. Loose or broken wire #40B from platform level switch S16 to base control module connector J3 pin 26 | Check continuity. Replace if defective |

4.2-36 No Platform Level Down from the Platform Console

- | | |
|---|---|
| 1. Loose or broken wire #04 from platform terminal block to platform level switch S19 | Check continuity. Replace if defective |
| 2. Defective platform level switch S19 | Check continuity through switch while activating platform level down function between wires #04 and #40A. Replace switch if no continuity |
| 3. Loose or broken wire #40A from platform level switch S19 to platform control module connector J13 pin 26 | Check continuity. Replace if defective |

4.2-37 No Platform Rotate or Jib Functions from the Base or Platform Consoles

- | | |
|---|--|
| 1. Loose or broken wire #42 from base control module connector J2 pin 12 to turret harness plug pin #20 | Check continuity. Replace if defective |
| 2. <i>Loose or broken wire #42 from turret harness plug pin #20 to platform flow enable valve 2H-42</i> | Check continuity. Replace if defective |
| 3. Loose or broken wire #02 from turret harness plug to platform flow enable valve 2H-42 | Check continuity. Replace if defective |
| 4. Defective platform flow enable coil 2H-42 | Check continuity and resistance through coil. Replace if defective |

4.2-38 No Platform Rotate Right from the Base or Platform Consoles

- | | |
|--|--|
| 1. Loose or broken wire #37 from platform control module connector J12 pin #1 to platform terminal strip | Check continuity. Replace if defective |
| 2. Loose or broken wire #37 from platform terminal strip to platform rotate right valve 4H-37 | Check continuity. Replace if defective |
| 3. Loose or broken wire #02 from platform terminal strip to platform rotate right valve 4H-37 | Check continuity. Replace if defective |
| 4. Defective platform rotate right coil 4H-37 | Check continuity and resistance through coil. Replace if defective |

4.2-39 No Platform Rotate Right from the Base Console

- | | |
|---|--|
| 1. Loose or broken wire #10A from IGN switch S5 to platform rotate switch S16 | Check continuity. Replace if defective |
| 2. Defective platform rotate switch S16 | Check continuity through switch while activating platform rotate right function between wires #10A and #37B. Replace switch if no continuity |
| 3. Loose or broken wire #37B from platform rotate switch S16 to base control module connector J2 pin 28 | Check continuity. Replace if defective |

4.2-40 No Platform Rotate Right from the Platform Console

- | | |
|--|---|
| 1. Loose or broken wire #04 from platform terminal block to platform rotate switch S20 | Check continuity. Replace if defective |
| 2. Defective platform level switch S20 | Check continuity through switch while activating platform rotate right function between wires #04 and #37A. Replace switch if no continuity |
| 3. Loose or broken wire #37A from platform rotate switch S20 to platform control module connector J13 pin 28 | Check continuity. Replace if defective |

4.2-41 No Platform Rotate Left from the Base or Platform Consoles

- | | |
|--|--|
| 1. Loose or broken wire #36 from platform control module connector J12 pin #2 to platform terminal strip | Check continuity. Replace if defective |
| 2. Loose or broken wire #36 from platform terminal strip to platform rotate left valve 4H-36 | Check continuity. Replace if defective |
| 3. Loose or broken wire #02 from platform terminal strip to platform rotate left valve 4H-36 | Check continuity. Replace if defective |
| 4. Defective platform rotate left coil 4H-36 | Check continuity and resistance through coil. Replace if defective |

4.2-42 No Platform Rotate Left from the Base Console

- | | |
|--|--|
| 1. Loose or broken wire #10A from IGN switch S5 to platform level switch S16 | Check continuity. Replace if defective |
| 2. Defective platform level switch S16 | Check continuity through switch while activating platform level down function between wires #10A and #36B. Replace switch if no continuity |
| 3. Loose or broken wire #36B from platform level switch S16 to base control module connector J3 pin 29 | Check continuity. Replace if defective |

4.2-43 No Platform Rotate Left from the Platform Console

- | | |
|--|--|
| 1. Loose or broken wire #04 from platform terminal block to platform rotate switch S20 | Check continuity. Replace if defective |
| 2. Defective platform level switch S20 | Check continuity through switch while activating platform rotate left function between wires #04 and #36A. Replace switch if no continuity |
| 3. Loose or broken wire #37A from platform rotate switch S20 to platform control module connector J13 pin 28 | Check continuity. Replace if defective |

4.2-44 No Jib Up from the Base or Platform Consoles

- | | |
|---|--|
| 1. Loose or broken wire #35 from platform control module connector J12 pin #13 to platform terminal strip | Check continuity. Replace if defective |
| 2. Loose or broken wire #35 from platform terminal strip to jib up valve 4H-35 | Check continuity. Replace if defective |
| 3. Loose or broken wire #02 from platform terminal strip to jib up valve 4H-35 | Check continuity. Replace if defective |
| 4. Defective jib up coil 4H-35 | Check continuity and resistance through coil. Replace if defective |

4.2-45 No Jib Up from the Base Console

- | | |
|---|---|
| 1. Loose or broken wire #10A from IGN switch S5 to jib switch S17 | Check continuity. Replace if defective |
| 2. Defective jib switch S17 | Check continuity through switch while activating jib up function between wires #10A and #35B. Replace switch if no continuity |
| 3. Loose or broken wire #35B from jib switch S17 to base control module connector J2 pin 28 | Check continuity. Replace if defective |

4.2-46 No Jib Up from the Platform Console

- | | |
|--|--|
| 1. Loose or broken wire #04 from platform terminal block to jib switch S21 | Check continuity. Replace if defective |
| 2. Defective jib switch S21 | Check continuity through switch while activating jib up function between wires #04 and #35A. Replace switch if no continuity |
| 3. Loose or broken wire #35A from jib switch S21 to platform control module connector J12 pin 28 | Check continuity. Replace if defective |

4.2-47 No Jib Down from the Base or Platform Consoles

- | | |
|---|--|
| 1. Loose or broken wire #34 from platform control module connector J12 pin #24 to platform terminal strip | Check continuity. Replace if defective |
| 2. Loose or broken wire #34 from platform terminal strip to jib down valve 4H-34 | Check continuity. Replace if defective |
| 3. Loose or broken wire #02 from platform terminal strip to jib down valve 4H-34 | Check continuity. Replace if defective |
| 4. Defective jib down coil 4H-34 | Check continuity and resistance through coil. Replace if defective |

4.2-48 No Jib Down from the Base Console

- | | |
|---|---|
| 1. Loose or broken wire #10A from IGN switch S5 to jib switch S17 | Check continuity. Replace if defective |
| 2. Defective jib switch S17 | Check continuity through switch while activating jib down function between wires #10A and #34B. Replace switch if no continuity |
| 3. Loose or broken wire #34B from jib switch S17 to base control module connector J2 pin 26 | Check continuity. Replace if defective |

4.2-49 No Jib Down from the Platform Console

- | | |
|--|--|
| 1. Loose or broken wire #04 from platform terminal block to jib switch S21 | Check continuity. Replace if defective |
| 2. Defective jib switch S21 | Check continuity through switch while activating jib down function between wires #04 and #34A. Replace switch if no continuity |
| 3. Loose or broken wire #34A from jib switch S21 to platform control module connector J12 pin 26 | Check continuity. Replace if defective |

4.2-50 No Drive or Steer Functions

- | | |
|---|--|
| 1. Loose or broken wire #04 from platform terminal block to drive joystick A2 | Check continuity. Replace if defective |
| 2. Loose or broken wire #02 from platform terminal block to drive joystick A2 | Check continuity. Replace if defective |
| 3. Defective drive joystick A2 | See drive joystick test procedure in section 5 |

4.2-51 No Forward or Reverse Drive

- | | |
|--|--|
| 1. No output on "D" when forward is selected on drive joystick A2 | See drive joystick test procedure in section 5 |
| 2. Loose or broken wire "D-signal" from drive joystick A2 to platform control module connector J13 pin #14 | Check continuity. Replace if defective |

4.2-52 No Forward Drive

- | | |
|--|--|
| 1. No output from base control module at connector J2 pin #1 to wire #16 | Check for correct output voltage. |
| 2. Loose or broken wire 16 from base control module connector J2 pin #1 to turret connector pin 21 | Check continuity. Replace if defective |
| 3. Loose or broken wire #16 from turret plug pin 21 to drive pump valve connector pin #4 | Check continuity. Replace if defective |
| 4. Loose or broken wire #16 from drive pump valve connector pin #4 to 3H-16 Forward coil | Check continuity. Replace if defective |
| 5. Loose or broken wire #02 wire from 3H-16 Forward coil to ground | Check continuity. Replace if defective |
| 6. Defective forward coil 3H-16 | Check continuity and resistance through coil. Replace if defective |

4.2-53 No Reverse Drive

1. No output from base control module at connector J2 pin #2 to wire #15	Check for correct output voltage.
2. Loose or broken wire 15 from base control module connector J2 pin #2 to turret connector pin 20	Check continuity. Replace if defective
3. Loose or broken wire #15 from turret plug pin 20 to drive pump valve connector pin #1	Check continuity. Replace if defective
4. Loose or broken wire #15 from drive pump valve connector pin #1 to 3H-15 Forward coil	Check continuity. Replace if defective
5. Loose or broken wire #02 wire from 3H-15 Reverse coil to ground	Check continuity. Replace if defective
6. Defective reverse coil 3H-15	Check continuity and resistance through coil. Replace if defective

4.2-54 The Brake will not Release

1. No output from base control module connector J3 pin #24 to wire #26	Check for correct output voltage
2. Loose or broken wire 26 from base control module connector J3 pin #24 to turret harness connector pin #8	Check continuity. Replace if defective
3. Loose or broken wire #26 from turret harness connector pin #8 to 3H-26 Brake coil	Check continuity. Replace if defective
4. Loose or broken wire #02 wire from 3H-26 Brake coil to ground	Check continuity. Replace if defective
5. Defective brake coil 3H-26	Check continuity and resistance through coil. Replace if defective

4.2-55 No Left Steer

1. Loose or broken wire #24P from drive joystick A2 to platform control module connector J12 pin #15	Check continuity. Replace if defective
2. No output from base control module on connector J3 pin #13	Check pin #13 for 12 volts. If no voltage present with foot on footswitch and activating steer function check section 5 for OCM pin voltage reference
3. Loose or broken wire #24 from base control module connector J3 pin #13 to turret harness connector pin #7	Check continuity. Replace if defective
4. Loose or broken wire #24 from turret harness plug pin #7 to left steer valve 4H-24	Check continuity. Replace if defective

- | | |
|--|--|
| 5. Loose or broken wire #02 from turret harness plug to left steer valve 4H-24 | Check continuity. Replace if defective |
| 6. Defective left steer valve coil 4H-24 | Check continuity and resistance through coil. Replace if defective |

4.2-56 No Right Steer

- | | |
|---|---|
| 1. Loose or broken wire #23P from drive joystick A2 to platform control module connector J12 pin #16 | Check continuity. Replace if defective |
| 2. No output from base control module on connector J3 pin #3 | Check pin #13 for 12 volts. If no voltage present with foot on footswitch and activating steer function check section 5 for OCM pin voltage reference |
| 3. Loose or broken wire #23 from base control module connector J3 pin 13 to turret harness connector pin #6 | Check continuity. Replace if defective |
| 4. Loose or broken wire #23 from turret harness plug pin #6 to right steer valve 4H-23 | Check continuity. Replace if defective |
| 5. Loose or broken wire #02 from turret harness plug to right steer valve 4H-23 | Check continuity. Replace if defective |
| 6. Defective right steer valve coil 4H-23 | Check continuity and resistance through coil. Replace if defective |

4.2-57 The Direction Sensing is Inoperative

- | | |
|--|--|
| 1. Loose or broken wire #09 from base terminal block to limit switch LS1 | Check continuity. Replace if defective |
| 2. Open or defective limit switch LS1 | Adjust limit switch if required. Check continuity through switch. Replace if defective |
| 3. Loose or broken wire #17 from limit switch LS1 to base terminal block | Check continuity. Replace if defective |
| 4. Loose or broken wire #17 from base terminal block to base control module connector J2 pin #25 | Check continuity. Replace if defective |
| 5. Defective base control module channel input for direction sense enable | Replace if Defective |

4.2-58 The Load Sense Indicates Overload or Overload Warning with the Platform Empty or Below Weight

- | | |
|------------------------------------|---|
| 1. Load sense mis-calibration | Refer to calibration procedure for recalibration of load cell |
| 2. Load cell circuit not operating | Check wiring from load cell to platform control module. Check CAN termination resistors. Check load cell. Repair or replace as required |

4.2-59 The Overload Indicator Light does not Turn On when the Platform is Overloaded

- | | |
|---|---|
| 1. Defective lamp | Check lamp. Replace if defective |
| 2. Load cell circuit not operating | Check wiring from load cell to platform control module. Check CAN termination resistors. Check load cell. Repair or replace as required |
| 3. Load sense out of calibration | Refer to calibration procedure for recalibration of load cell |
| 4. No output control module | Check Voltage at platform control module connectpr J3 pin #7 for 12V when platform is loaded with 110% of rated capacity. (Boom fully retracted and 12" (30cm) off the ground.) |
| 5. Loose or broken wire #82 from the platform control module connector J13 pin 7 to overload lamp PL10. | Check continuity. Replace if defective |
| 6. Loose or broken wire #02 from overload lamp to platform terminal strip | Check continuity. Replace if defective |

4.2-60 The Audible Alarm does not Turn On with the Platform Overloaded

- | | |
|--|--|
| 1. Defective alarm BP3 | Check alarm. Replace if defective |
| 2. Loose or broken wire #118 from platform control module connector J13 pin 8 to alarm BP3 | Check continuity. Replace if defective |
| 3. Loose or broken wire #02 from alarm BP3 to platform terminal block | Check continuity. Replace if defective |

4.3 Hydraulic System

4.3-1 All Controls Inoperative

- | | |
|--|--|
| 1. Broken or defective drive pump shaft or coupling. | Check pump shaft and coupling. Replace if defective. |
| 2. Hydraulic oil level low. | Check oil level. Fill to proper level. |

4.3-2 All Boom Functions Inoperative

- | | |
|---|---|
| 1. Open or defective dump valve 2H-21A. | Clean valve. Check O-rings on valve. Check operation of valve. Repair or replace valve as required. |
| 2. Stuck or defective relief valve RV6. | Set valve to specifications. Check O-rings and clean valve. Repair or replace valve as required. |
| 3. Stuck or defective Inlet Compensator/ differential sensing valve DSV1. | Check O-rings and clean valve. Check operation of valve. Repair or replace valve as required. |
| 4. System pump P2 defective. | Test pump with flow meter. Replace if defective. |
| 5. Plugged or defective high pressure filter F1. | Check filter. Replace if plugged or defective. |

4.3-3 No Main Boom Up

- | | |
|--|---|
| 1. Stuck or defective lift up valve 4H-14. | Clean valve. Check operation of valve. Repair or replace valve as required. |
| 2. Stuck or defective shuttle valve SV6. | Clean valve. Check O-rings on valve. Check operation of valve. Repair or replace valve as required. |
| 3. Stuck or defective check valve CV10. | Clean valve. Check operation of valve. Repair or replace valve as required. |
| 4. Stuck or defective differential sensing valve DSV4. | Clean valve. Check O-rings on valve. Check operation of valve. Repair or replace valve as required. |
| 5. Stuck or defective counterbalance valve CB9. | Clean valve. Check O-rings on valve. Repair or replace valve as required. |
| 6. Defective lift cylinder C3. | Check seals on cylinder. Replace as necessary. Replace cylinder if defective. |

4.3-4 No Main Boom Down

1. Stuck or defective lift down valve 4H-13.	Clean valve. Check operation of valve. Repair or replace valve as required.
2. Stuck or defective shuttle valve SV6.	Clean valve. Check O-rings on valve. Check operation of valve. Repair or replace valve as required.
3. Stuck or defective check valve CV10.	Clean valve. Check operation of valve. Repair or replace valve as required.
4. Stuck or defective differential sensing valve DSV4.	Clean valve. Check O-rings on valve. Check operation of valve. Repair or replace valve as required.
5. Stuck or defective counterbalance valve CB9.	Clean valve. Check O-rings on valve. Repair or replace valve as required.
6. Defective lift cylinder C3.	Check seals on cylinder. Replace as necessary. Replace cylinder if defective.

4.3-5 No Riser Boom Up

1. Stuck or defective riser up valve 4H-31.	Clean valve. Check operation of valve. Repair or replace valve as required.
2. Stuck or defective shuttle valve SV5.	Clean valve. Check O-rings on valve. Check operation of valve. Repair or replace valve as required.
3. Stuck or defective check valve CV5.	Clean valve. Check O-rings on valve. Check operation of valve. Repair or replace valve as required.
4. Stuck or defective check valve CV8.	Clean valve. Check operation of valve. Repair or replace valve as required.
5. Stuck or defective differential pressure sensing valve DSV3.	Clean valve. Check O-rings on valve. Check operation of valve. Repair or replace valve as required.
6. Stuck or defective counterbalance valve CB5 or CB6.	Clean valve. Check O-rings on valve. Repair or replace valve as required.
7. Defective riser cylinder C6 or C7.	Check seals on cylinder. Replace as necessary. Replace cylinder if defective.

4.3-6 No Riser Boom Down

1. Stuck or defective riser down valve 4H-30.	Clean valve. Check operation of valve. Repair or replace valve as required.
2. Stuck or defective shuttle valve SV5.	Clean valve. Check O-rings on valve. Check operation of valve. Repair or replace valve as required.
3. Plugged or defective orifice OR6.	Check orifice. Replace if plugged or defective.
4. Stuck or defective check valve CV6.	Clean valve. Check O-rings on valve. Check operation of valve. Repair or replace valve as required.
5. Stuck or defective relief valve RV8.	Set valve to specifications. Check O-rings and clean valve. Repair or replace valve as required.
6. Stuck or defective check valve CV8.	Clean valve. Check operation of valve. Repair or replace valve as required.
7. Stuck or defective differential pressure sensing valve DSV3.	Clean valve. Check O-rings on valve. Check operation of valve. Repair or replace valve as required.
8. Stuck or defective counterbalance valve CB5 or CB6.	Clean valve. Check O-rings on valve. Repair or replace valve as required.
9. Defective riser cylinder C6 or C7.	Check seals on cylinder. Replace as necessary. Replace cylinder if defective.

4.3-7 Riser Boom Down Jerky

1. Stuck open or defective check valve CV5.	Clean valve. Check operation of valve. Repair or replace valve as required.
2. Stuck or incorrectly set counterbalance valve CB5 or CB6.	Clean valve. Check O-rings on valve. Check operation of valve. Repair or replace valve as required.

4.3-8 No Turret Rotate Left

1. Stuck or defective rotate left valve 4H-32.	Clean valve. Check operation of valve. Repair or replace valve as required.
2. Stuck or defective shuttle valve SV4.	Clean valve. Check O-rings on valve. Check operation of valve. Repair or replace valve as required.
3. Stuck or defective relief valve RV7.	Set valve to specifications. Check o-rings and clean valve. Repair or replace valve as required.

4. Stuck or defective differential pressure sensing valve DSV2.	Clean valve. Check O-rings on valve. Check operation of valve. Repair or replace valve as required.
5. Stuck or defective shuttle valve SV3.	Clean valve. Check O-rings on valve. Check operation of valve. Repair or replace valve as required.
6. Stuck or defective counterbalance valve CB4.	Clean valve. Check O-rings on valve. Repair or replace valve as required.
7. Stuck or defective check valve CV7.	Clean valve. Check operation of valve. Repair or replace valve as required.
8. Turret rotate brake BR2 not releasing.	Inspect brake for worn seals or broken components. Repair and replace as necessary.
9. Worn or defective swing drive motor RA2.	Check motor. Repair or replace if defective.

4.3-9 No Turret Rotate Right

1. Stuck or defective rotate right valve 4H-33.	Clean valve. Check operation of valve. Repair or replace valve as required.
2. Stuck or defective shuttle valve SV4.	Clean valve. Check O-rings on valve. Check operation of valve. Repair or replace valve as required.
3. Stuck or defective relief valve RV7.	Set valve to specifications. Check o-rings and clean valve. Repair or replace valve as required.
4. Stuck or defective differential pressure sensing valve DSV2.	Clean valve. Check O-rings on valve. Check operation of valve. Repair or replace valve as required.
5. Stuck or defective shuttle valve SV3.	Clean valve. Check O-rings on valve. Check operation of valve. Repair or replace valve as required.
6. Stuck or defective counterbalance valve CB3.	Clean valve. Check O-rings on valve. Repair or replace valve as required.
7. Stuck or defective check valve CV7.	Clean valve. Check operation of valve. Repair or replace valve as required.
8. Turret rotate brake BR2 not releasing.	Inspect brake for worn seals or broken components. Repair and replace as necessary.
9. Worn or defective swing drive motor RA2.	Check motor. Repair or replace if defective.

4.3-10 No Boom Extend

1. Stuck or defective boom extend valve 3H-39.	Clean valve. Check operation of valve. Repair or replace valve as required.
2. Plugged, incorrectly adjusted or defective orifice OR3.	Check orifice. Replace if plugged or defective.
3. Stuck in the shifted position or defective boom retract valve 3H-38.	Clean valve. Check operation of valve. Repair or replace valve as required.
4. Stuck or defective check valve CV11.	Clean valve. Check operation of valve. Repair or replace valve as required.
5. Stuck or defective counterbalance valve CB10.	Clean valve. Check O-rings on valve. Repair or replace valve as required.
6. Defective extension cylinder C2.	Check seals on cylinder. Replace as necessary. Replace cylinder if defective.

4.3-11 No Boom Retract

1. Stuck or defective boom retract valve 3H-38.	Clean valve. Check operation of valve. Repair or replace valve as required.
2. Plugged, incorrectly adjusted or defective orifice OR3.	Check orifice. Replace if plugged or defective.
3. Stuck or defective check valve CV11.	Clean valve. Check operation of valve. Repair or replace valve as required.
4. Stuck or defective counterbalance valve CB11.	Clean valve. Check O-rings on valve. Repair or replace valve as required.
5. Defective extension cylinder C2.	Check seals on cylinder. Replace as necessary. Replace cylinder if defective

4.3-12 No Jib Up

1. Stuck or defective jib enable valve 2H-42.	Clean valve. Check O-rings on valve. Check operation of valve. Repair or replace valve as required.
2. Stuck or defective differential pressure sensing valve DSV5.	Clean valve. Check O-rings on valve. Check operation of valve. Repair or replace valve as required.
3. Stuck or defective check valve CV12.	Clean valve. Check operation of valve. Repair or replace valve as required.
4. Stuck or defective jib up valve 4H-35.	Clean valve. Check operation of valve. Repair or replace valve as required.
5. Stuck or defective counterbalance valve CB12.	Clean valve. Check O-rings on valve. Repair or replace valve as required.
6. Defective jib cylinder C1.	Check seals on cylinder. Replace as necessary. Replace cylinder if defective.

4.3-13 No Jib Down

1. Stuck or defective jib enable valve 2H-42.	Clean valve. Check O-rings on valve. Check operation of valve. Repair or replace valve as required.
2. Stuck or defective differential pressure sensing valve DSV5.	Clean valve. Check O-rings on valve. Check operation of valve. Repair or replace valve as required.
3. Stuck or defective check valve CV12.	Clean valve. Check operation of valve. Repair or replace valve as required.
4. Stuck or defective jib down valve 4H-34.	Clean valve. Check operation of valve. Repair or replace valve as required.
5. Stuck or defective counterbalance valve CB13.	Clean valve. Check O-rings on valve. Repair or replace valve as required.
6. Defective jib cylinder C1.	Check seals on cylinder. Replace as necessary. Replace cylinder if defective.

4.3-14 No Platform Rotation Right

1. Stuck or defective platform rotate enable valve 2H-42.	Clean valve. Check O-rings on valve. Check operation of valve. Repair or replace valve as required.
2. Stuck or defective differential pressure sensing valve DSV5.	Clean valve. Check O-rings on valve. Check operation of valve. Repair or replace valve as required.
3. Stuck or defective check valve CV12.	Clean valve. Check operation of valve. Repair or replace valve as required.
4. Stuck or defective platform rotate right valve 4H-37.	Clean valve. Check operation of valve. Repair or replace valve as required.
5. Stuck or defective counterbalance valve CB14.	Clean valve. Check O-rings on valve. Repair or replace valve as required.
6. Defective rotary actuator RA1.	Check actuator. Repair or replace as necessary.

4.3-15 No Platform Rotation Left 4

1. Stuck or defective platform rotate enable valve 2H-42.	Clean valve. Check O-rings on valve. Check operation of valve. Repair or replace valve as required.
2. Stuck or defective differential pressure sensing valve DSV5.	Clean valve. Check O-rings on valve. Check operation of valve. Repair or replace valve as required.
3. Stuck or defective check valve CV12.	Clean valve. Check operation of valve. Repair or replace valve as required.
4. Stuck or defective platform rotate right valve 4H-36.	Clean valve. Check operation of valve. Repair or replace valve as required.
5. Stuck or defective counterbalance valve CB15.	Clean valve. Check O-rings on valve. Repair or replace valve as required.
6. Defective rotary actuator RA1.	Check actuator. Repair or replace as necessary.

4.3-16 Platform will not Level Down Manually

1. Plugged, incorrectly adjusted or defective orifice OR4.	Check orifice. Replace if plugged or defective.
2. Stuck or defective platform level down valve 4H-40.	Clean valve. Check operation of valve. Repair or replace valve as required.
3. Stuck or defective shuttle valve SV7.	Clean valve. Check O-rings on valve. Check operation of valve. Repair or replace valve as required.
4. Stuck or defective shuttle valve SV8.	Clean valve. Check O-rings on valve. Check operation of valve. Repair or replace valve as required.
5. Stuck or defective check valve CV4.	Clean valve. Check O-rings on valve. Check operation of valve. Repair or replace valve as required.
6. Stuck or defective relief valve RV9.	Set valve to specifications. Check O-rings and clean valve. Repair or replace valve as required.
7. Stuck or defective counterbalance valve CB8.	Clean valve. Check O-rings on valve. Repair or replace valve as required.
8. Stuck or defective check valve CV9.	Clean valve. Check operation of valve. Repair or replace valve as required.
9. Defective leveling cylinder C4 or slave cylinder C5.	Check seals on cylinder. Replace as necessary. Replace cylinder if defective.

4.3-17 Platform will not Level Up Manually

1. Plugged, incorrectly adjusted or defective orifice OR4.	Check orifice. Replace if plugged or defective.
2. Stuck or defective platform level down valve 4H-41.	Clean valve. Check operation of valve. Repair or replace valve as required.
3. Stuck or defective shuttle valve SV7.	Clean valve. Check O-rings on valve. Check operation of valve. Repair or replace valve as required.
4. Stuck or defective shuttle valve SV8.	Clean valve. Check O-rings on valve. Check operation of valve. Repair or replace valve as required.
5. Stuck or defective check valve CV4.	Clean valve. Check O-rings on valve. Check operation of valve. Repair or replace valve as required.
6. Stuck or defective relief valve RV9.	Set valve to specifications. Check O-rings and clean valve. Repair or replace valve as required.
7. Stuck or defective counterbalance valve CB7.	Clean valve. Check O-rings on valve. Repair or replace valve as required.
8. Stuck or defective check valve CV9.	Clean valve. Check operation of valve. Repair or replace valve as required.
9. Defective leveling cylinder C4 or slave cylinder C5.	Check seals on cylinder. Replace as necessary. Replace cylinder if defective.

4.3-18 Brake will not Release

1. Stuck or defective shuttle valve SV2.	Clean valve. Check O-rings on valve. Check operation of valve. Repair or replace valve as required.
2. Defective or misadjusted pressure reducing valve PR1.	Set valve to specifications. Check O-rings and clean valve. Repair or replace valve as required.
3. Stuck or defective brake valve 3H-26.	Clean valve. Check O-rings on valve. Check operation of valve. Repair or replace valve as required.
4. Stuck or defective shuttle valve SV1.	Clean valve. Check O-rings on valve. Check operation of valve. Repair or replace valve as required.
5. Defective or misadjusted relief valve RV4.	Set valve to specifications. Check O-rings and clean valve. Repair or replace valve as required.
6. Stuck or defective brake release override valve V1.	Clean valve. Check O-rings on valve. Repair or replace valve as required.
7. Bypassing or defective brake hand pump V3.	Clean valve. Check O-rings on valve. Repair or replace valve as required.
8. Bypassing or defective brake cylinder C12.	Check seals on cylinder. Replace as necessary. Replace cylinder if defective

4.3-19 Brake will not Engage

- | | |
|---|--|
| 1. Brake cylinder defective. | Check cylinders. Repair or replace as necessary. |
| 2. Brake valve 3H-26 stuck in shifted position. | Check valve. Replace if defective. |
| 3. Brake inside axle out of adjustment. | See section 5 for brake adjustment procedure. |

4.3-20 Differential Lock will not Engage

- | | |
|---|---|
| 1. Stuck or defective shuttle valve SV2. | Clean valve. Check O-rings on valve. Check operation of valve. Repair or replace valve as required. |
| 2. Defective or misadjusted pressure reducing valve PR1. | Set valve to specifications. Check O-rings and clean valve. Repair or replace valve as required. |
| 3. Stuck or defective differential lock valve 3H-165. | Clean valve. Check O-rings on valve. Check operation of valve. Repair or replace valve as required. |
| 4. Bypassing or defective differential lock cylinder C13. | Check seals on cylinder. Replace as necessary. Replace cylinder if defective |

4.3-21 No Drive Forward or Reverse

- | | |
|---|--|
| 1. Brake not releasing. | See "brake will not release" in this section. |
| 2. Defective or misadjusted charge pump relief valve RV3. | Set valve to specifications. Check O-rings and clean valve. Repair or replace valve as required. |
| 3. Plugged or defective charge pump filter F1. | Check filter. Replace if plugged or defective. |
| 4. Worn charge pump P1A. | Check pump. Replace if defective. |
| 5. Defective pump displacement control 4H-15 and 4H-16. | Check control. Replace if defective. |
| 6. Open bypass valve V4. | Close bypass valve. |
| 7. Worn drive pump P1. | Check pump. Replace if defective. |
| 8. Worn or defective drive motor M1. | Check motor. Replace if defective. |

4.3-22 No Forward Drive

- | | |
|---|---|
| 1. Defective pump displacement control 4H-16. | Check control. Replace if defective. |
| 2. Defective or misadjusted drive relief valve RV1. | See section 5 for drive pump set up procedures. |
| 3. Drive pump servo stuck or not shifting. | Check pump. Replace if defective. |

4.3-23 No Reverse Drive

- | | |
|---|---|
| 1. Defective pump displacement control 4H-15. | Check control. Replace if defective. |
| 2. Defective or misadjusted drive relief valve RV2. | See section 5 for drive pump set up procedures. |
| 3. Drive pump servo stuck or not shifting. | Check pump. Replace if defective. |

4.3-24 No High Speed Drive

- | | |
|---|---|
| 1. Stuck or defective 2 speed valve 3H-45. | Clean valve. Check O-rings on valve. Check operation of valve. Repair or replace valve as required. |
| 2. Defective shift spool in drive motor M1. | Check motor. Repair or replace if necessary. |

4.3-25 No Right Steer

- | | |
|---|---|
| 1. Plugged, incorrectly adjusted or defective priority flow control PFC1. | Check operation. Set flow rate to 1.25 GPM @ 2000 psi. Replace if plugged or defective. |
| 2. Stuck or defective right steer valve 4H-23A. | Clean valve. Check operation of valve. Repair or replace valve as required. |
| 3. Defective steer cylinder C8. | Check seals on cylinder. Replace as necessary. Replace cylinder if defective. |

4.3-26 No Left Steer

- | | |
|---|---|
| 1. Plugged, incorrectly adjusted or defective priority flow control PFC1. | Check operation. Set flow rate to 1.25 GPM @ 2000 psi. Replace if plugged or defective. |
| 2. Stuck or defective left steer valve 4H-24A. | Clean valve. Check operation of valve. Repair or replace valve as required. |
| 3. Defective steer cylinder C8. | Check seals on cylinder. Replace as necessary. Replace cylinder if defective. |

4.3-27 Axle Will Not Oscillate



NOTE

Axle will only oscillate when boom is fully retracted and is horizontal or below.

- | | |
|--|---|
| 1. Stuck or defective axle lockout valve 3H-65. | Clean valve. Check O-rings on valve. Repair or replace valve as required. |
| 2. One or more counterbalance valves (CB1 or CB2) failed to shift or is defective. | Clean valve. Check O-rings on valve. Repair or replace valve as required. |

4.3-28 Axle Will Not Lock

**NOTE**

Axle is in constant float if boom is fully retracted and is horizontal or below.

-
- | | |
|---|--|
| 1. Axle lockout valve 3H-65 is stuck in shifted position or is defective. | Clean valve. Check O-rings on valve. Check operation of valve. Repair or replace valve as required. |
| 2. Bypassing or defective axle lock cylinders C9 and C10. | Check seals on cylinder. Replace as necessary. Replace cylinder if defective. |
| 3. Counterbalance valves (CB1 or CB2) out of adjustment or are defective. | Clean valve. Check O-rings on valve. Repair or replace valve as required. |
-

Section 5 – Procedures

5.1 General

The following information is provided to assist you in the use and application of servicing and maintenance procedures contained in this chapter.



NOTE

The illustrations shown in this manual are for instructional purposes only. The models and components shown may appear somewhat different from those on your actual MEWP.



5.1-1 Safety and Workmanship

Your safety, and that of others, is the first consideration when engaging in the maintenance of equipment. Always be conscious of weight. Never attempt to move heavy parts without the aid of a mechanical device. Do not allow heavy objects to rest in an unstable position. When raising a portion of the equipment, ensure that adequate support is provided.

Before performing routine maintenance underneath the riser, support it using a suitably rated lifting device (refer to Figure 01), or cylinder chocks on both riser cylinders. Contact Skyjack Parts to order chocks.

WARNING

Remove all material and personnel from the platform while using the maintenance support(s).

1. Park the MEWP on a firm, level surface.
2. Retract and lower the boom, riser, and platform until the MEWP is in the stowed position.
3. Turn the engine off.
4. Pull out the emergency stop buttons  on the base controls and on the platform controls.
5. Turn the battery disconnect switch to the off position .

After completing any procedure which involves modifying, adjusting, or replacing any hydraulic or electrical components, perform all of the function tests given in your unit's Operating Manual.

WARNING

Make sure you maintain three points of contact when mounting and dismounting the platform.

WARNING

Do not operate any platform controls without the proper fall protection secured to the designated location in the platform. Failure to do so could result in death or serious injury!

WARNING

Make sure there are no people or obstructions in the test area, and there is sufficient space for the boom and drive functions required for the given procedures.

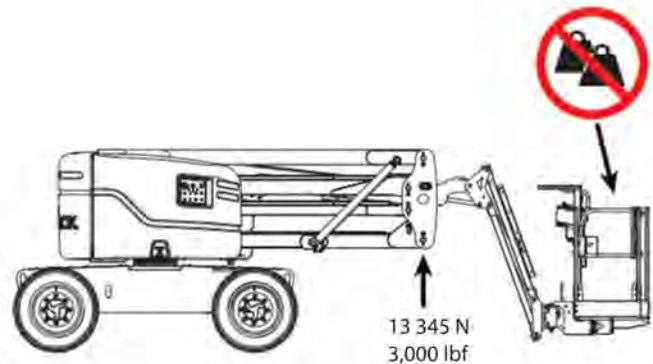

Figure 01 Support location

5.2 Platform

5.2-1 Human Machine Interface (HMI)

Maintaining proper calibration is essential for good performance of the MEWP.

To access the OC1-1 console, open the platform control cover.

The OCI-1 has an integrated multi segment, two line display with membrane keys that allow it to be used as the main interface to system controls and adjustments. The Human Machine Interface (referred to as the HMI) will serve as your window into the application software to allow the operator to monitor/adjust the following information:

- Active Function Being Used
- Part Number and Serial Number
- Restore the Factory Default Settings
- Output Calibrations (Tresh, Max, Ramp.etc)
- I-O Status
- CANBus Status

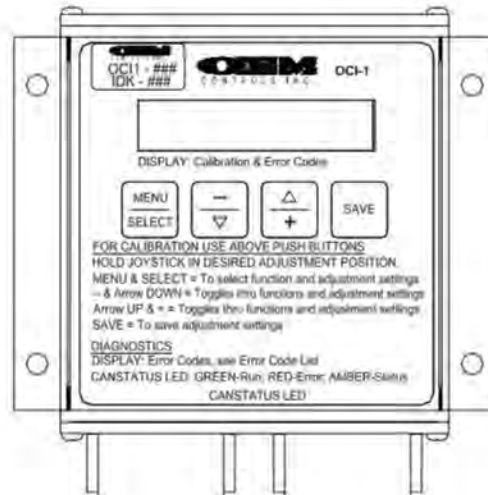

5.2-2 User Interface Keys

1.0		1.0-1 <MENU> enters a new menu screen and/or 1.0-2 <SELECT> select the flashing item.
1.1		1.1-1 <MINUS> decreases an adjustable parameter such as ramp time. 1.1-2 <DOWN> selects the previous item in the current menu's list.
1.2		1.2-1 <PLUS> increases an adjustable parameter. 1.2-2 <UP> selects the next item in the current menu's list.
1.3		1.3-1 <SAVE> saves the new data to EEPROM (permanent memory storage).
1.4		Simultaneously pressing <UP> and <DOWN> resets the HMI to menu screen 0.

5.2-3 SCM Character Functions Charts

SCM Keypad	
Keys	Short Form
Menu/Select	(M/S)
▼/-	(-)
▲/+	(+)
Save/Exit	(S/E)

Function Attribute	
THRESH	Threshold
RAMPDN	Ramp Down
RAMPUP	Ramp Up
LOWRNG	Low Range
MAXOUT	Maximum Output

1345AA

5.2-4 SCM Function Channel Names

SCM Function (Channel) Names	
DRIVE REV Fn01A	Drive Reverse
DRIVE FWD Fn01B	Drive Forward
CHAN 2A Fn02A	Brakes
CHAN 2B Fn02B	Differential Lock Enable
BOOM DOWN Fn03A	Main Boom Down
BOOM UP Fn03B	Main Boom Up
ROTATE L Fn04A	Turret Rotate Left
ROTATE R Fn04B	Turret Rotate Right
RISER DN Fn05A	Riser Down
RISER UP Fn05B	Riser Up
RISER UP Fn06A	Virtual channel
RISER UP Fn06B	Virtual channel

1346AA

5.2-5 SCM Pin Reference

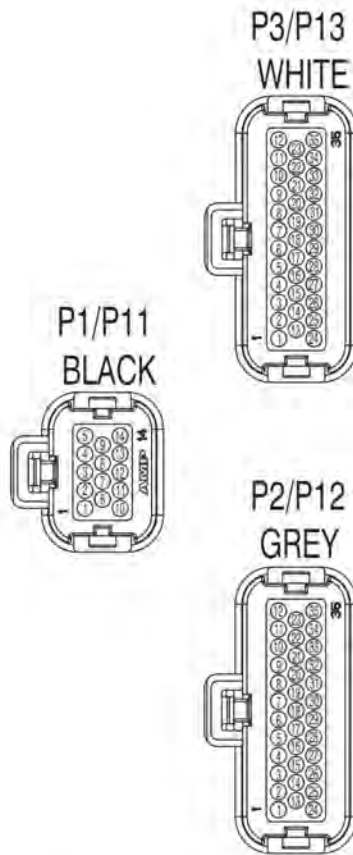

P1 (Black) Lower Main Controller: SMB1-105					
Pin	Wire	Function	Input/Output Type	I/O Test	I/O Error
1	09		Power		VS1
2	09		Power		VS2
3	09		Power		VS3
4	09		Power		VS4
5		Not used			Vreg 5v
6	CAN H	CANH to Engine ECU & Telematics	J1939 CAN		
7	CAN L	CANL to Engine ECU & Telematics	J1939 CAN		
8	CAN 2H	CANH to PLTF SMB1-106	CANopen		
9	CAN 2L	CANL to PLTF SMB1-106	CANopen		
10	02		Ground		GND1
11	02		Ground		GND2
12	02		Ground		GND3
13	02		Ground		GND4
14		Not used			--

2056AC

P2 (Grey) Lower Main Controller: SMB1-105					
Pin	Wire	Function	Input/Output Type	I/O Test	I/O Error
1	16	Drive Forward	Analog Output	PWM02	PE2
2	15	Drive Reverse	Analog Output	PWM01	PE1
3	31	Riser Up	Analog Output	PWM08	PE8
4	30	Riser Down	Analog Output	PWM07	PE7
5	14	Boom Up	Analog Output	PWM06	PE6
6	13	Boom Down	Analog Output	PWM05	PE5
7	41	Platform Level Up	Analog Output	PWM12	PE12
8	13A	SJ63 AJ Boom Down Throttle	Analog Output	PWM11	PE11
	85B	SJ46 AJ 2nd Generator O/P			
9	38	Fly Boom In	Analog Output	PWM10	PE10
10	39	Fly Boom Out	Analog Output	PWM09	PE9
11		Not Used		--	--
12	42	Proportional Flow	Analog Output	PWM15	PE15
13	32	Turret Rotate Left	Analog Output	PWM03	PE3
14	55	Fuel level float sw	Digital Input	DI2	IE2
15	14B	Main Boom Up	Digital Input	DI4	IE4
16	13B	Main Boom Dn	Digital Input	DI6	IE6
17	32B	Turret Rotate L	Digital Input	DI8	IE8
18	10A	Emergency Pump / Enable	Digital Input	DI10	IE10
19	29	Fly Boom In LS (Hi Speed Drive)	Digital Input	DI12	IE12
20	12	Platform key position	Digital Input	DI14	IE14
21	38B	Telescope Retract	Digital Input	DI16	IE16
22	41B	Platform Level Up	Digital Input	DI18	IE18
23		Not Used		--	--
24	33	Turret Rotate Right	Analog Output	PWM04	PE4
25	17	Direction Sensing	Digital Input	DI1	IE1
26	34B	Jib Down	Digital Input	DI3	IE3
27	28	Tilt Switch Active	Digital Input	DI5	IE5
28	35B	Jib Up	Digital Input	DI7	IE7
29	59	Main Boom Cradled LS (Hi Speed Drive)	Digital Input	DI9	IE9
30	57	Engine Start Request	Digital Input	DI11	IE11
31	10	Base key position	Digital Input	DI13	IE13
32	33B	Turret Rotate R	Digital Input	DI15	IE15
33	39B	Telescope Extend	Digital Input	DI17	IE17
34		Not Used		--	--
35	40	Platform Level Down	Analog Output	PWM13	PE13

2057AC

P3 (White) Lower Main Controller: SMB1-105					
Pin	Wire	Function	Input/Output Type	I/O Test	I/O Error
1	119	Load Zone Border Lamp	Digital Output	DO1	OE1
2	01A	Emergency Pump Relay	Digital Output	DO8	OE8
3	23	Steer Right	Digital Output	DO7	OE7
4	118A	Overload Alarm/lamp	Digital Output	DO6	OE6
5	65	Axle Lock	Digital Output	DO5	OE5
6	120	Low capacity zone lamp	Digital Output	DO12	OE12
7	85	Generator Solenoid	Digital Output	DO11	OE11
8	68	Engine Run Enable	Digital Output	DO10	OE10
9	57A	Engine Start	Digital Output	DO9	OE9
10	20	All-Motion Alarm	Digital Output	DO16	OE16
11	120A	High capacity zone lamp	Digital Output	DO15	OE15
12		Not Used	Digital Output	DO14	OE14
13	24	Steer Left	Digital Output	DO2	OE2
14		Not Used	Analog Input	AI1	AE1
15		Not Used	Analog Input	AI2	AE2
16		Not Used	Analog Input	AI3	AE3
17		Not Used	Analog Input	AI4	AE4
18		Not Used	Analog Input	AI5	AE5
19		Not Used	Analog Input	AI6	AE6
20	128	Angle Sensor - Chassis	Analog Input	AI7	AE7
21		Not Used	Analog Input	AI8	AE8
22		Not Used	Analog Input	AI9	AE9
23	11	Propane Run (Dual Fuel) Load Kit Option (ANSI/CSA D2.9L)	Digital Output	DO13	OE13
24	21A	Dump Valve	Digital Output	DO3	OE3
25	45A	Motor 2 Speed	Digital Output	DO4	OE4
26	40B	Platform Level Down	Digital Input	DI19	IE19
27		Main Boom Creep (used on 86)	Digital Input	DI20	IE20
28	37B	Platform Rotate Right	Digital Input	DI21	IE21
29	36B	Platform Rotate Left	Digital Input	DI22	IE22
30		Riser Down	Digital Input	DI23	IE23
31		Riser Up	Digital Input	DI24	IE24
32	121	load zone safety limit (Main)	Digital Input	DI25	IE25
33	122	load zone safety limit (Fly)	Digital Output	DI26	IE26
34	26	Holding Brake Off	Digital Output	DO17	OE17
35	165	Diff Lock	Digital Output	DO18	OE18

2058AD

P11 (Black) Upper Secondary Controller: SMB1-106					
Pin	Wire	Function	Input/Output Type	I/O Test	I/O Error
1	04		Power		VS1
2	04		Power		VS2
3	04		Power		VS3
4	04		Power		VS4
5	L	Speed control supply (T Booms)			Vreg 5v
6		Not Used	J1939 CAN		
7		Not Used	J1939 CAN		
8	CAN 2H	CANH To PLTF SMB1-106	CANopen		
9	CAN 2L	CANL To PLTF SMB1-106	CANopen		
10	02		Ground		GND1
11	02		Ground		GND2
12	02		Ground		GND3
13	02		Ground		GND4
14		Not used			--

2059AC

P12 (Grey) Upper Secondary Controller: SMB1-106					
Pin	Wire	Function	Input/Output Type	I/O Test	I/O Error
1	37	Platform Rotation Right		PWM17	PE17
2	36	Platform Rotation Left		PWM16	PE16
3		Not Used		PWM18	PE18
4		Not Used		--	--
5		Not Used		PWM21	PE21
6		Not Used		PWM20	PE20
7		Not Used		--	--
8		Not Used		--	--
9		Not Used		--	--
10		Not Used		--	--
11		Not Used		--	--
12		Not Used		--	--
13	35	Jib Up		PWM18	PE18
14	08A	Footswitch Actuated	Y	DI28	IE28
15	24P	Steer Left	Y	DI30	IE30
16	23P	Steer Right	Y	DI32	IE32
17	45	High Torque Drive Mode Selected	Y	DI34	IE34
18	01	Emergency Pump Request	Y	DI36	IE36
19	04A	Engine Run/Enable		DI38	IE38
20		MPS2 = KC O/H (Korea)	Y	DI40	IE40
21	38A	Fly Boom In	Y	DI42	IE42
22	41A	Platform Level Up	Y	DI44	IE44
23		Not Used		--	--
24	34	Jib Down		PWM19	PE19
25	233	Glazier Load Restrict		DI27	IE27
26	34A	Jib Down	Y	DI29	IE29
27		Not Used	Y	DI31	IE31
28	35A	Jib Up	Y	DI33	IE33
29	78	High Throttle Selected	Y	DI35	IE35
30	57B	Engine Start Request	Y	DI37	IE37
31		MPS1 = KC O/H (Korea)	Y	DI39	IE39
32	11A	Propane Fuel Select (Dual Fuel) Load Kit Option (ANSI/CSA TD2.9L)		DI41	IE41
33	39A	Fly Boom Out	Y	DI43	IE43
34		Not Used		--	--
35		Not Used		--	--

2060AC

P13 (White) Upper Secondary Controller: SMB1-106

PIn	Wire	Function	Input/Output Type	I/O Test	I/O Error
1		Not Used	Y	DO19	OE19
2	55	Low Fuel Indicator Lamp	Y	DO26	OE26
3	577	EcoStart Indicator Light		DO25	OE25
4	27A	Tilt Audible Indicator	Y	DO24	OE24
5	231	Regen Lamp (EU Stage 5 engine)		DO23	OE23
6	63	SGE Alarm		DO30	OE30
7	82	O/L Lamp		DO29	OE29
8	118	O/L Alarm		DO28	OE28
9	74	Glow Plug Indicator Lamp	Y	DO27	OE27
10	119	Load Zone Border Lamp		DO34	OE34
11	120A	High capacity zone lamp		DO33	OE33
12	120	Low capacity zone lamp		DO32	OE32
13	27	5 Degree Tilt LED Indicator		DO20	OE20
14	D	Drive Controller	Y	AI10	AE10
15	Y	Main Boom Elevation Controller	Y	AI11	AE11
16	X	Turret controller	Y	AI12	AE12
17		Not Used	Y	AI13	AE13
18		Not Used	Y	AI14	AE14
19	R	Riser Controller (AJ Booms)		AI15	AE15
20		Not Used	Y	AI16	AE16
21		Not Used	Y	AI17	AE17
22	C	Speed control knob (T booms)	Y	AI18	AE18
23	76P	MIL		DO31	OE31
24		Not Used		DO21	OE21
25	08	Footswitch Indicator	Y	DO22	OE22
26	40A	Platform Level Down	Y	DI45	IE45
27	232	Regen Temp. Override (EU Stage 5 engine)		DI46	IE46
28	35A	Platform Rotate Right	Y	DI47	IE47
29	36A	Platform Rotate Left	Y	DI48	IE48
30	165A	Diff Lock	Y	DI49	IE49
31	85	Generator On/Off	Y	DI50	IE50
32	61	SGE - Bar In	Y	DI51	IE51
33	62	Reset SGE	Y	DI52	IE52
34		Not Used		--	--
35	165B	Diff Lock Indicator		DO36	OE36

2061AC

5.2-6 SCM Recommended Settings - Kubota WG972 Dual Fuel Engine

Function	Thresh (mA)	Maxout (mA)	Low Rng (mA)	Ramp Up (sec)	Ramp Dn (sec)
Drive REV	400	750	580 ■	3	0.2
Drive FWD	400	710	520 ■	3	0.2
Rotate L ANSI (CE)	400	1350 (820)	900 (700) ■	1	1
Rotate R ANSI (CE)	400	1000 (750)	880 (750) ■	1	1
Boom DN	450	630	520 ■	1	1 ◆
Boom UP	470	720	630 ■	2	1 ◆
Fly IN	470	1200	920 ■	1	0.2
Fly OUT	470	1200	920 ■	1	0.2
Riser UP	470	960	510 ■	1	0.7
Riser DN	470	1080	600 ■	1	0.7
Jib UP	420	900	900 ■	0	0
Jib DN	420	900	900 ■	0	0
Platform R	350	900	900 ■	0	0
Platform L	340	900	900 ■	0	0
Level UP	400	1200	N/A	0	0
Level DN	400	1200	N/A	0	0
JIB FL UP	450	700	630 ■	1	0.7
JIB FL DN	450	670	500 ■	1	0.7
Platform Flow	340	640	520 ■	1	0.7
Function	Fwd	Rev			
Low Range B	714	760			
Drive Threshold	530	530			
LRNG Pmax ◆	940 ◆	930 ◆			
LRNG Pmin ◆	530 ◆	530 ◆			
B Boundary	Default	Default			
Drive Timer	Default	Default			
Function	Up	Dn			
Boom Creep	N/A	N/A			
Ramp Time	N/A				
PID Setting	KP	KI	KD		
AntiStall	23	10	30		
DF Setting	RPM	Torque			
AntiStall	99	75%			
Steer Settings	T1	T2			
AntiStall	1900	1800			

■ This is the maximum value allowed.

◆ Do not modify this setting.

2168AA

5.2-7 Default Recommended Settings - Kubota D1305 Diesel Engine

Function	Thresh (mA)	Maxout (mA)	Low Rng (mA)	Ramp Up (sec)	Ramp Dn (sec)
Drive REV	400	850	610 ■	3	0.2
Drive FWD	400	850	610 ■	3	0.2
Rotate L ANSI (CE)	400	1318 (820)	980 (820) ■	1	1
Rotate R ANSI (CE)	400	1000 (790)	880 (790) ■	1	1
Boom DN	450	780	680 ■	1	1.5 ◆
Boom UP	470	840	700 ■	2	1 ◆
Fly IN	470	1200	920 ■	1	0.2
Fly OUT	470	1200	930 ■	1	0.2
Riser UP	470	990	800 ■	1	0.7
Riser DN	470	700	600 ■	1	0.7
Jib UP	420	900	900 ■	0	0
Jib DN	420	900	900 ■	0	0
Platform R	340	870	870 ■	0	0
Platform L	340	870	870 ■	0	0
Level UP	400	1200	680 ■	0	0
Level DN	400	1200	680 ■	0	0
JIB FL UP	450	770	700 ■	1	0.7
JIB FL DN	450	750	610 ■	1	0.7
Platform Flow	340	670	600 ■	1	0.7
Function	Fwd	Rev			
Low Range B	864	868			
Drive Threshold	530	530			
LRNG Pmax ◆	940 ◆	930 ◆			
LRNG Pmin ◆	600 ◆	580 ◆			
B Boundary	Default	Default			
Drive Timer	Default	Default			
Function	Up	Dn			
Boom Creep					
Ramp Time					
PID Setting	KP	KI	KD		
Antistall	23	10	30		
Diesel Setting	RPMinitial	RPMexit	%initial	%more	%less
Antistall	600	400	70%	20%	10%
Steer Settings	T1	T2			
AntiStall	1600	1500			

■ This is the maximum value allowed.

◆ Do not modify this setting.

2169AA

5.2-8 Unlock and Modify the SCM

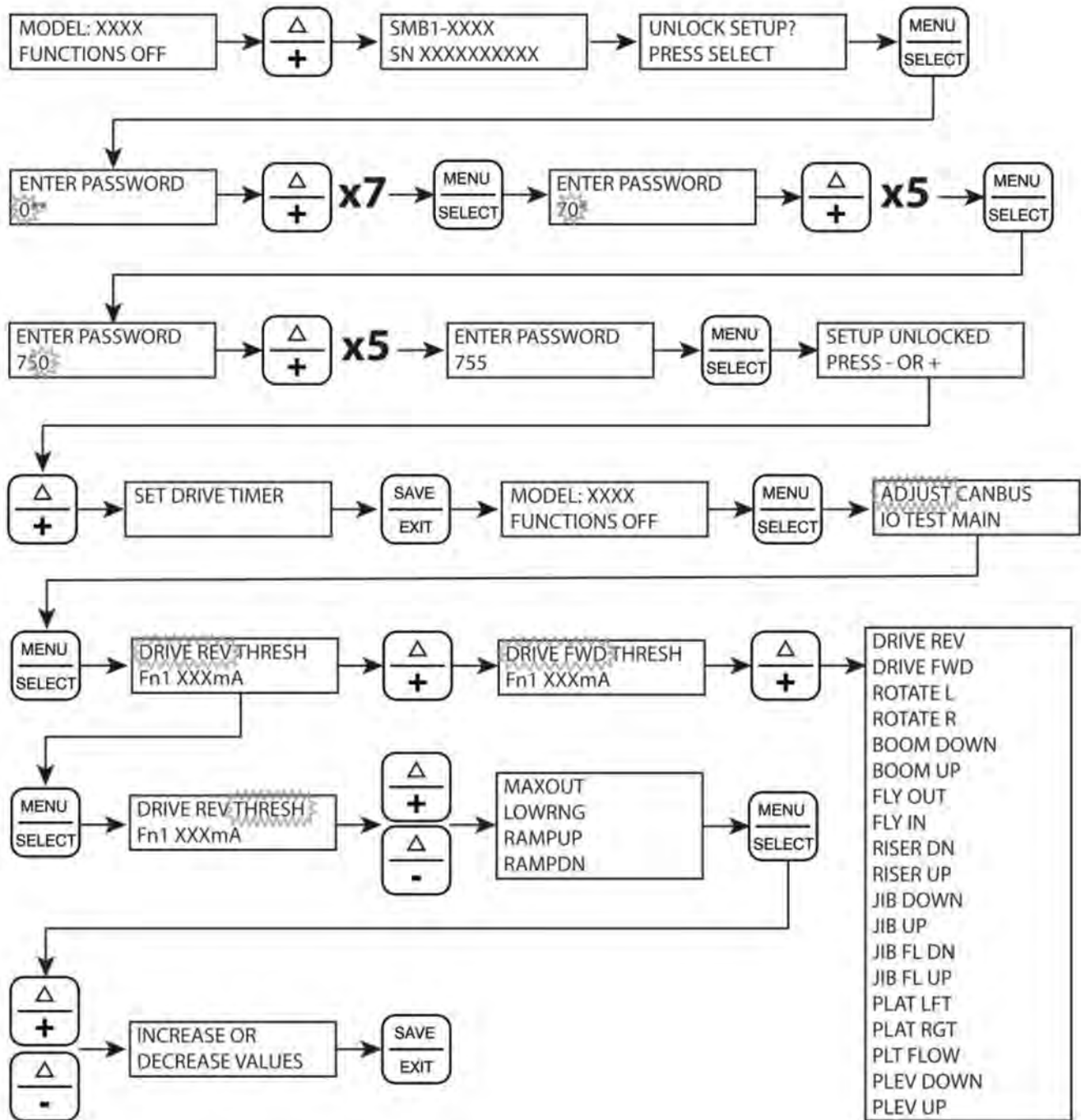

5.2-9 SCM Model Select

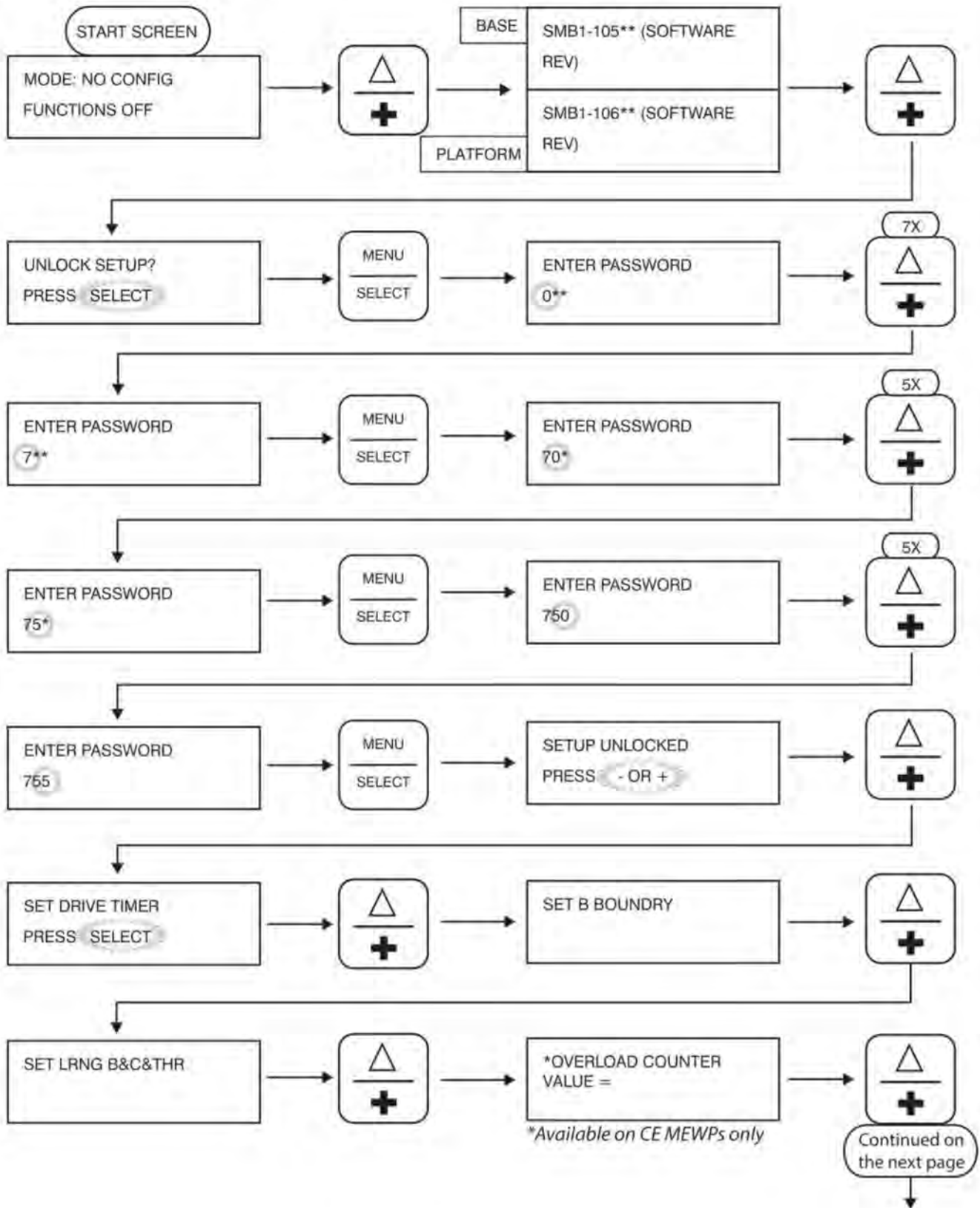

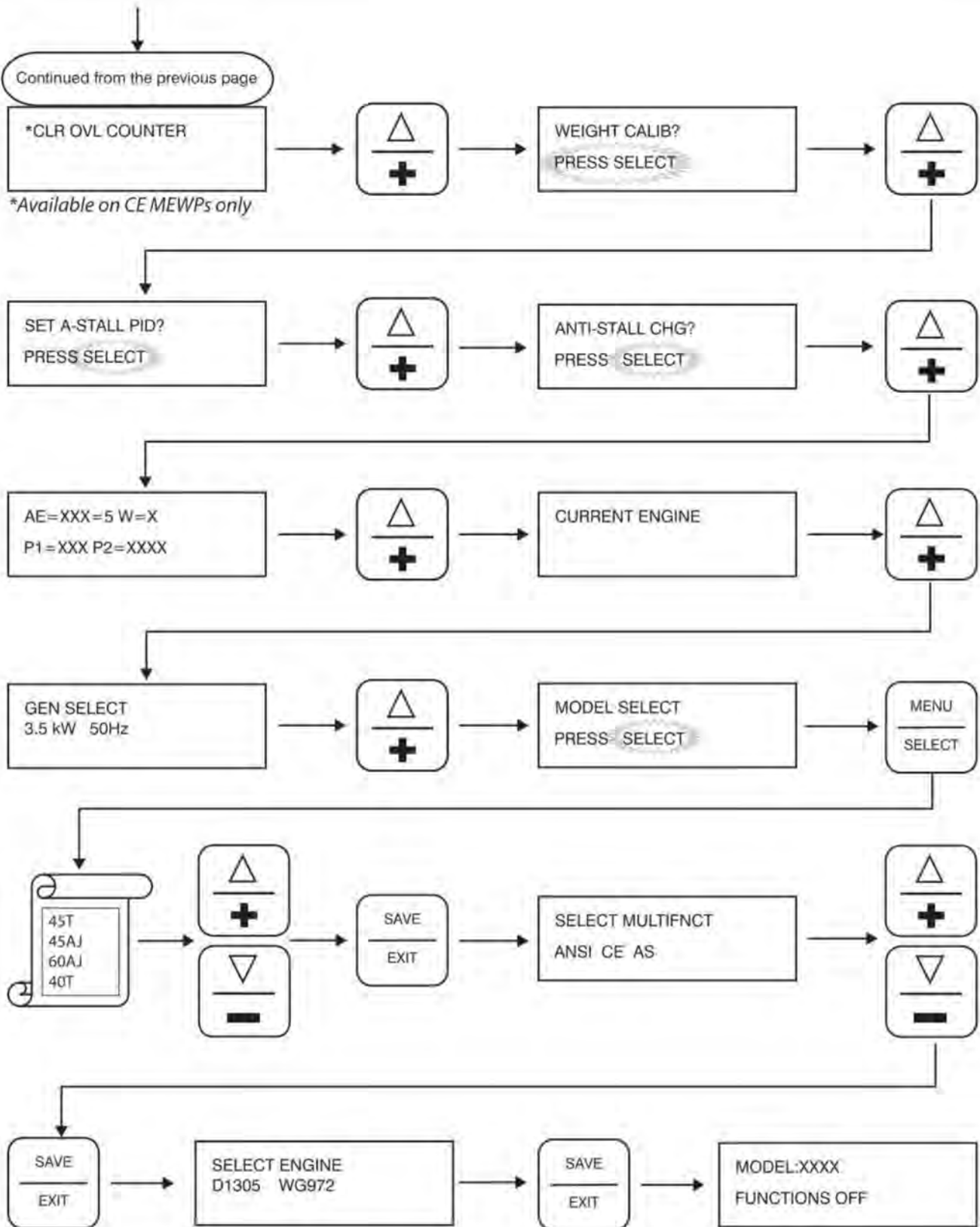

5.2-10 Check I/O Error

If a fault is detected, the engine shuts off and the SCM displays “Check I/O Err? Press select”.

Press Menu/Select.

This check helps to determine which channel has the fault.

PE=PWM error

OE=Digital output error

IE=Digital input error

AE=Analog error

Scroll through to the end of the first set of channels, then use Menu/Select to enter into the next channel menu. Make sure to repeat through all four channel menus.

Use the 5.2-5 SCM Pin Reference chart to determine which function each channel is related to. A properly working channel is indicated by a “0”. A fault is indicated by a “1”.

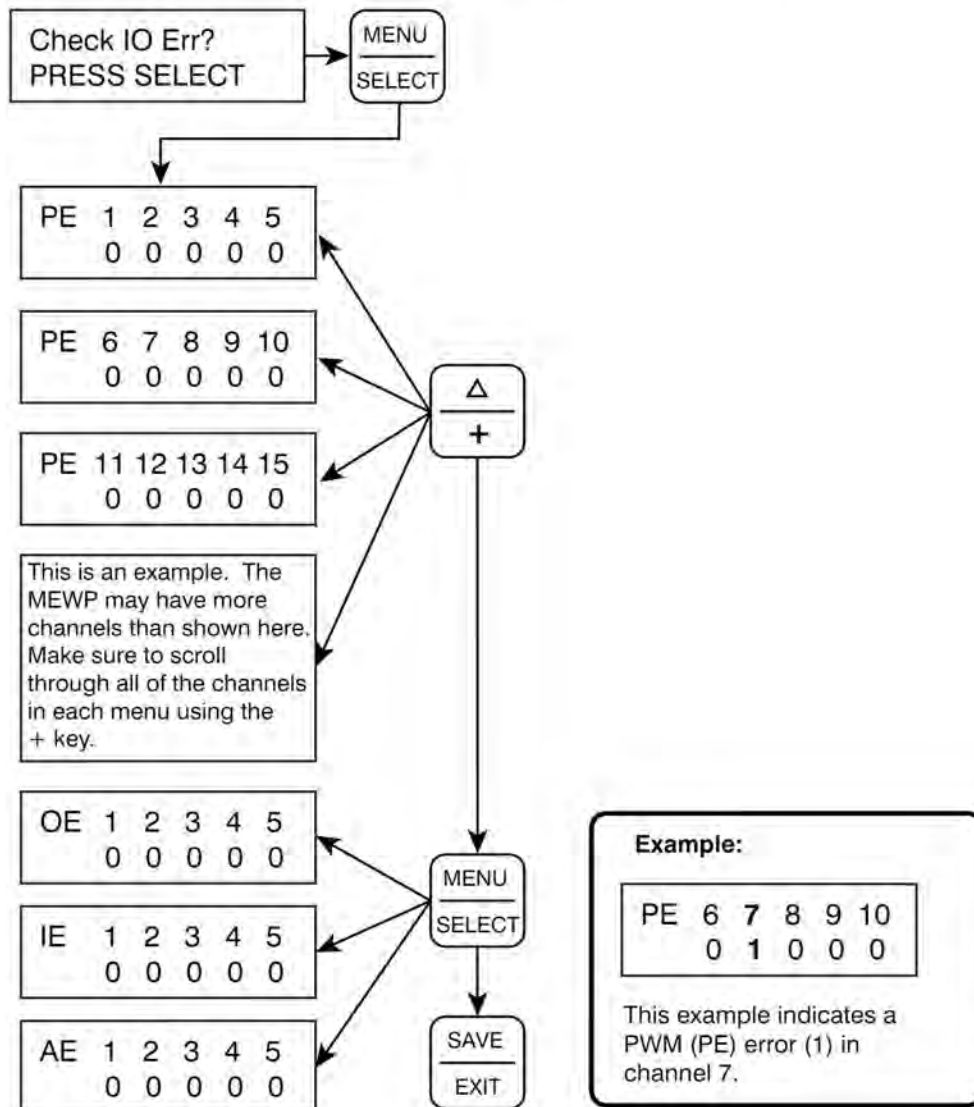

5.2-11 SCM Calibration

Tare weight calibration sets the unladen weight of the platform. It is the weight of an empty platform that the SCM subtracts from the gross weight reading of the load cell, giving a new zero (net) weight to start from when measuring the contents of the platform.

Net weight = Gross weight - Tare weight

Net weight: the weight of the platform.

Gross weight: the total weight as measured by the load cell.

Tare weight: the weight of the empty platform as set by the tare weight calibration.

1. Make sure the platform is level.
2. Remove all items from the platform, including optional attachments.
3. Make sure the **capacity derate switch** ❶ is in the full capacity position, and the **capacity derate light** ❷ is not on.

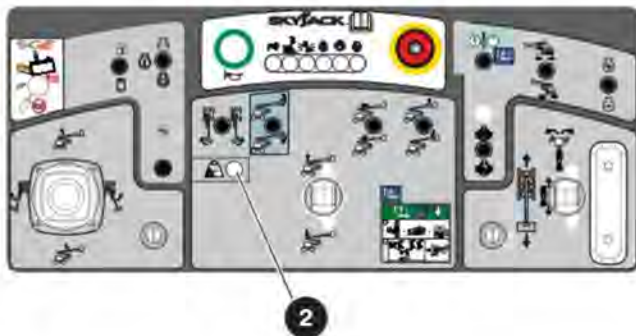
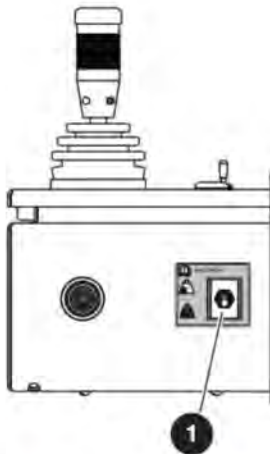

4. Do the calibration procedure from the **SCM** ❸ in the base control box. Follow the flowchart on the next page.

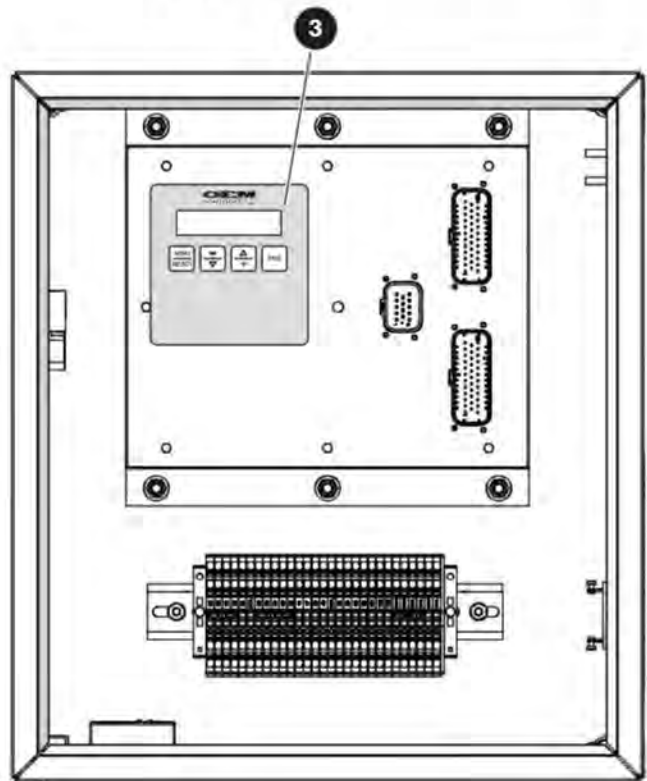

5.2-12 SCM Calibration Flowchart

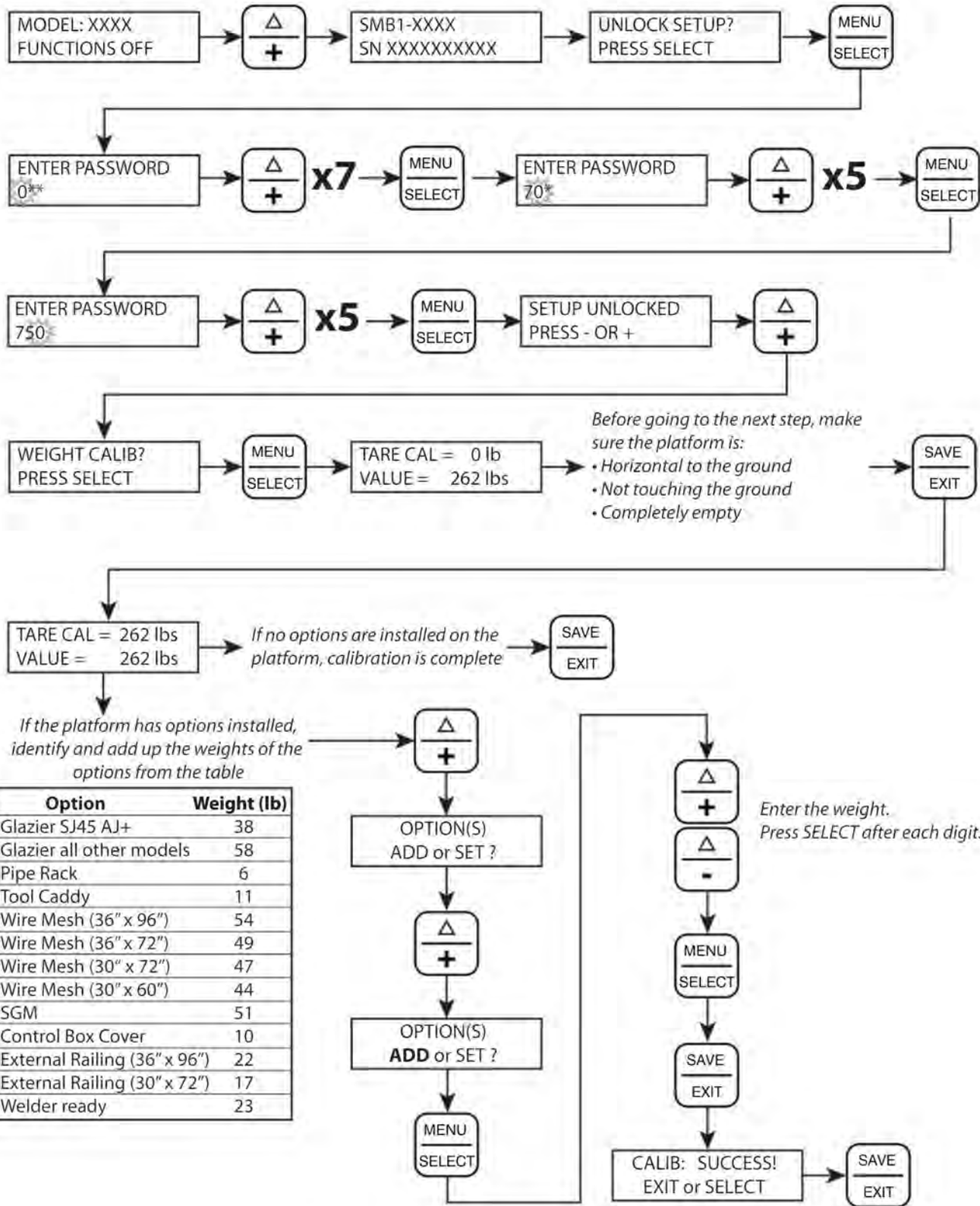

Option	Weight (lb)
Glazier SJ45 AJ+	38
Glazier all other models	58
Pipe Rack	6
Tool Caddy	11
Wire Mesh (36" x 96")	54
Wire Mesh (36" x 72")	49
Wire Mesh (30" x 72")	47
Wire Mesh (30" x 60")	44
SGM	51
Control Box Cover	10
External Railing (36" x 96")	22
External Railing (30" x 72")	17
Welder ready	23

5.2-13 CAN Bus Communication Check

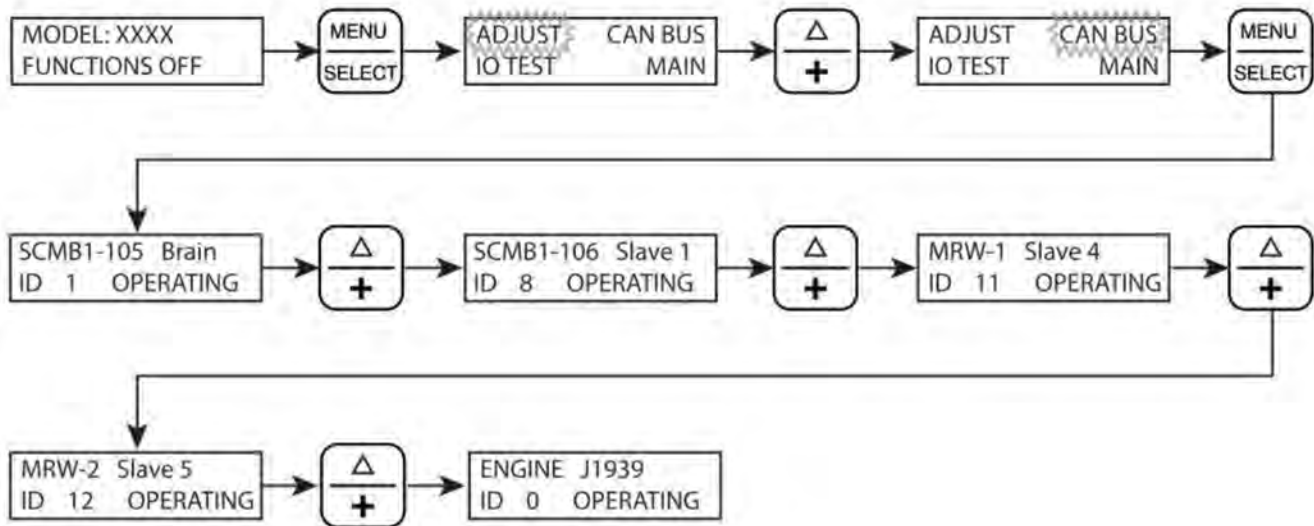

All channels must be "OPERATING".

If a channel is not reading correctly (OPERATING), "NO DATA" is shown.

Look at each channel for several seconds to confirm that it is not switching from "OPERATING" to "NO DATA".

SCMB1-105 Brain is the lower controller

SCMB1-106 Slave is the upper controller

MRW-1 Slave 4 ID 11 is CAN from the load cell. If it is not operating, "LOAD CELL 1 LOST" appears on the screen when powered on.

MRW-2 Slave 5 ID 12 is CAN from the load cell. If it is not operating, "LOAD CELL 2 LOST" appears on the screen when powered on.

ENGINE J1939 is CAN from the engine.

5.2-14 Fly Boom Switch Voltage References

TELESCOPE SWITCH WORKSHEET VOLTAGE DIVIDER CIRCUIT

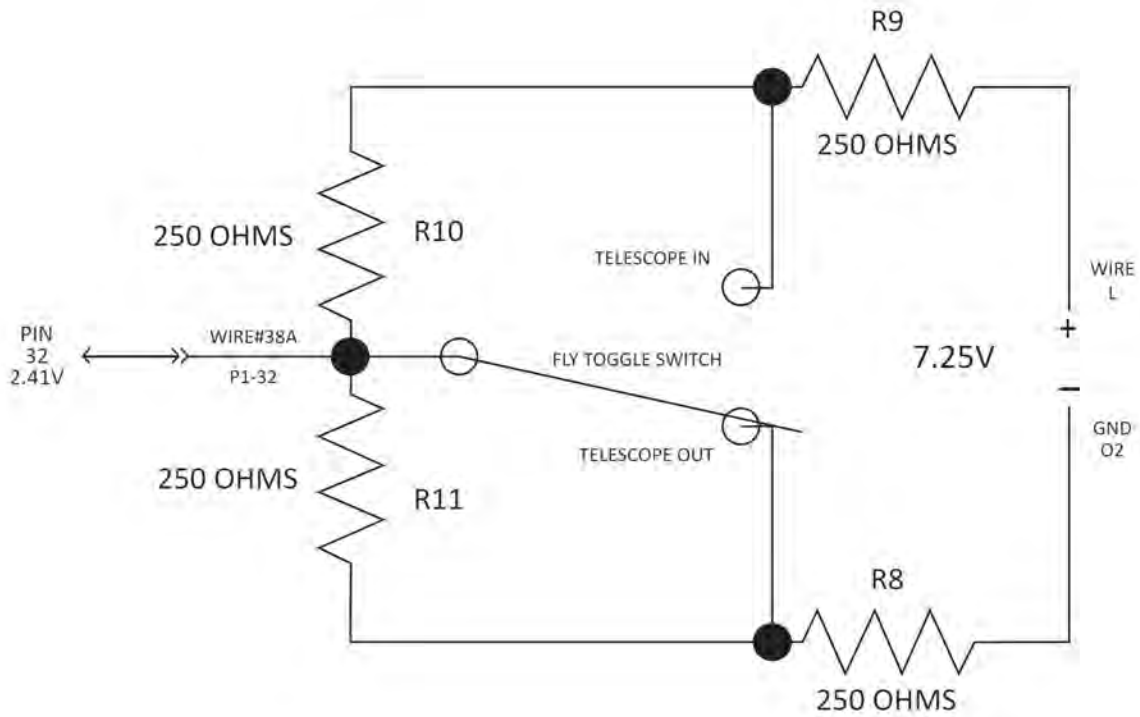
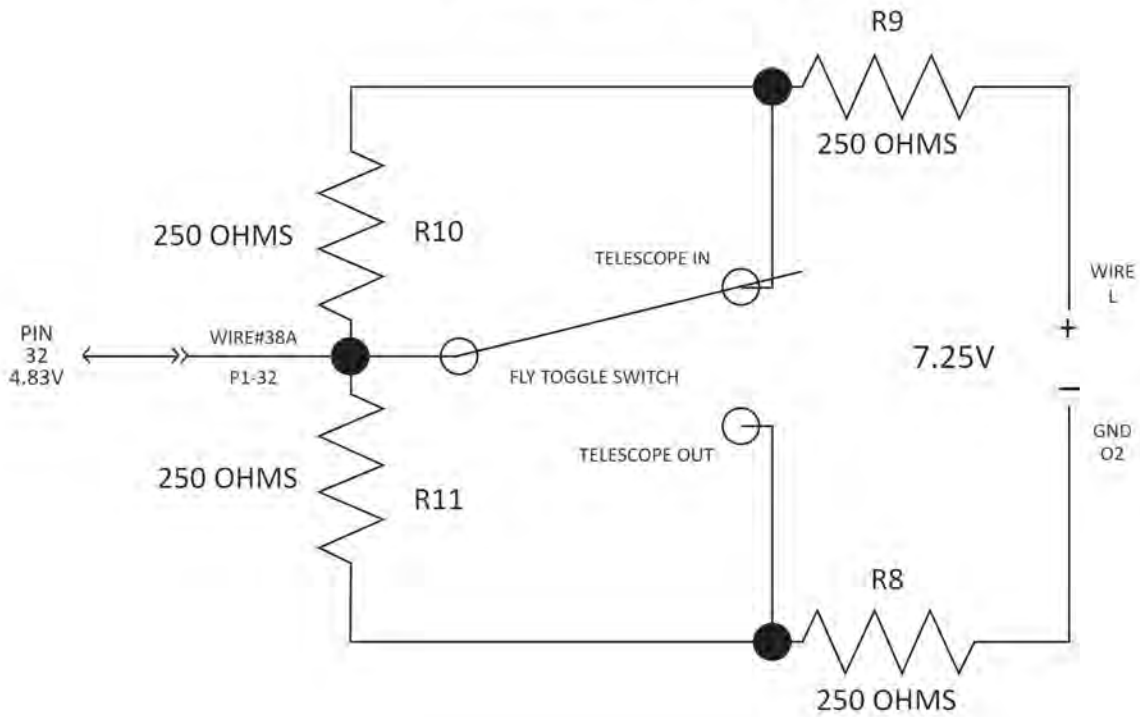

5.2-15 Platform Controller Voltage References

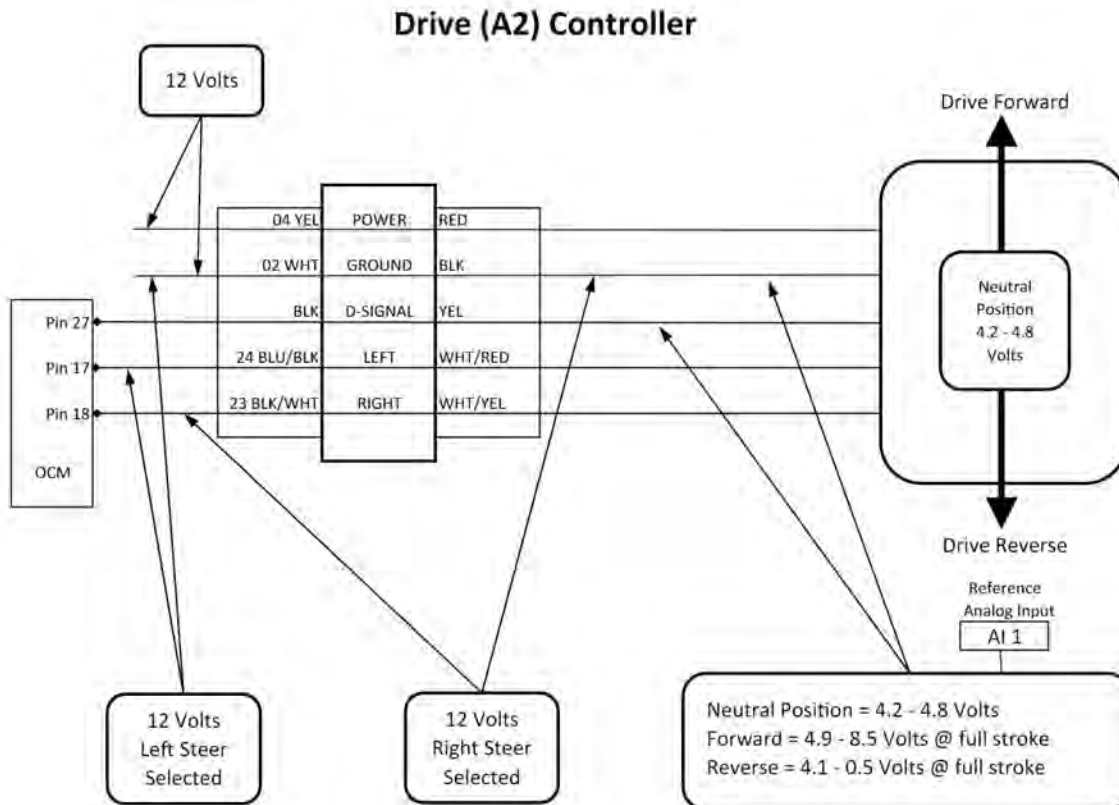
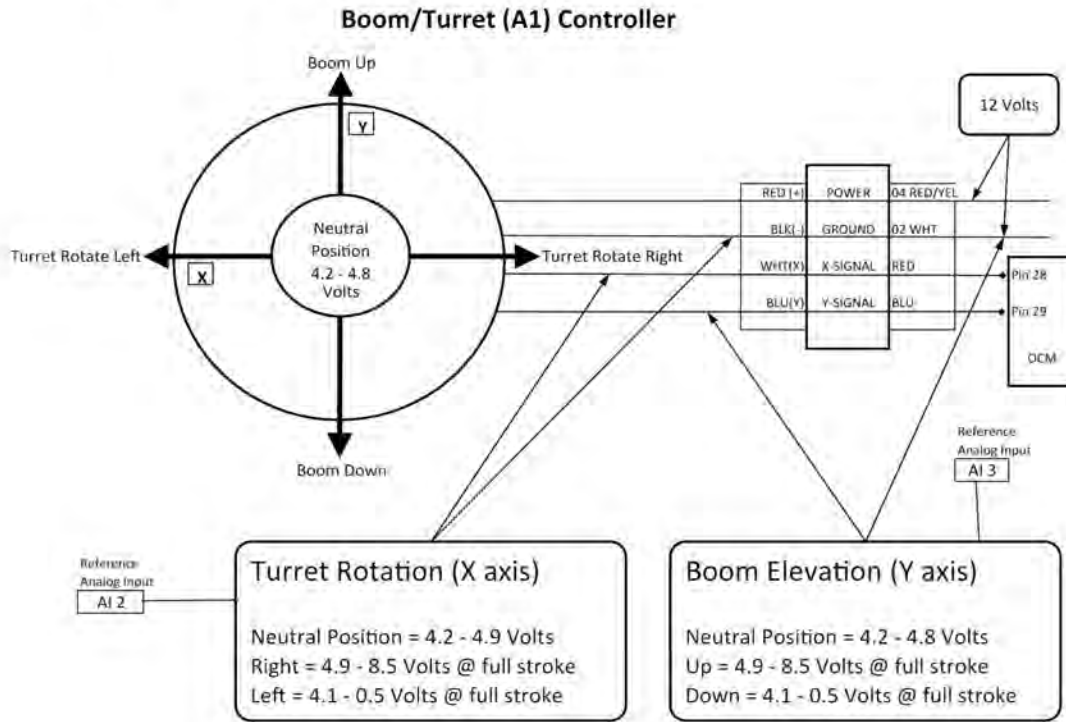

5.3 Boom

5.3-1 Check Wear Pads

1. Ensure the MEWP is on a firm level surface and is in the stowed position.
2. Start the engine from the base control console.
3. Raise the main boom to a comfortable working height (chest high), and then extend fly boom approximately 30 cm (1 ft).
4. Measure the thickness of each wear pad, and replace wear pad if it is less than 11 mm (7/16").
5. If the wear pad is within the specified thickness, shim it as necessary.

5.3-2 Shim Wear Pads

1. Ensure the MEWP is on a firm level surface and is in the stowed position.
2. Raise the main boom to a comfortable working height (chest high) and extend the fly boom until the wear pads are accessible.
3. Loosen the wear pad fasteners.
4. Shim the wear pads as necessary to obtain zero to 1/32" (0.8 mm) clearance and zero drag.

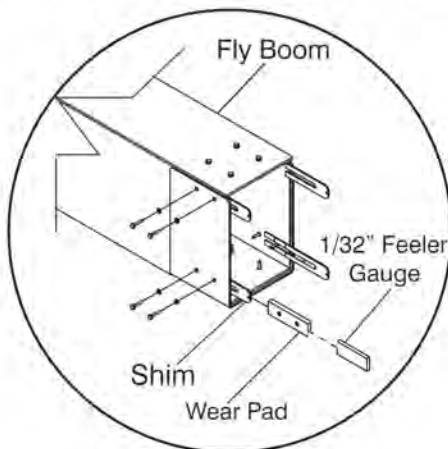

5. Extend and retract the fly boom through the entire range of motion and observe for loose points.



NOTE

Always maintain squareness between the boom's outer and inner tubes.

5.3-3 Cable Carrier Repair

To repair the cable carrier, simply use a screwdriver. Snap each crossbar off from either side of the chain, either by hand or by using the screwdriver as a lever. Install new crossbars by snapping the links together.

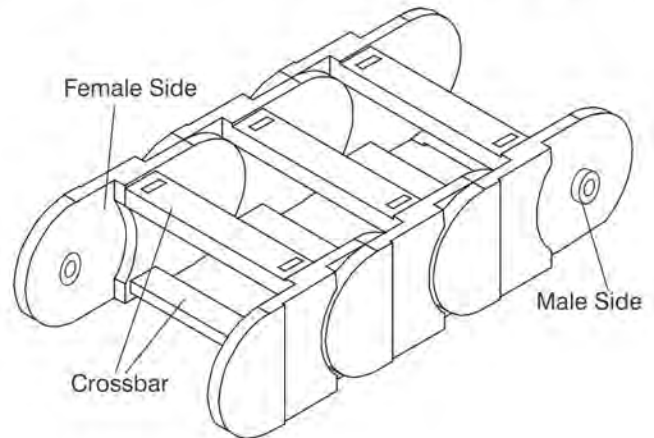

5.3-4 Rotary Actuator Bolt Torque Procedure

WARNING

Maintaining proper torque is essential to safe MEWP operation. Improper bolt torque could result in an unsafe operating condition and component damage.

1. Set the torque wrench to 25 Nm (17 ft-lb) and tighten the mounting bolts in a cross pattern sequence.

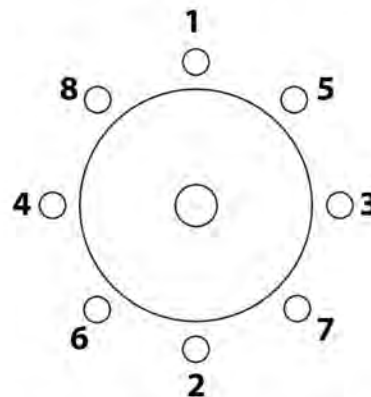

2. Set the torque wrench to 47 Nm (35 ft-lb) and tighten mounting bolts with the same sequence.
3. Torque the center bolt to 650 Nm (480 ft-lb).

5.3-5 Master Cylinder Replacement

1. Ensure the MEWP is parked on a firm and level surface.

⚠ WARNING

Ensure that there is sufficient room for boom to swing and elevate.

⚠ WARNING

Be aware of overhead obstructions or other possible hazards around the machine when lifting.

2. By using the base controls, position the machine as below to allow for easy work access to the basket/jib boom and the master cylinder.

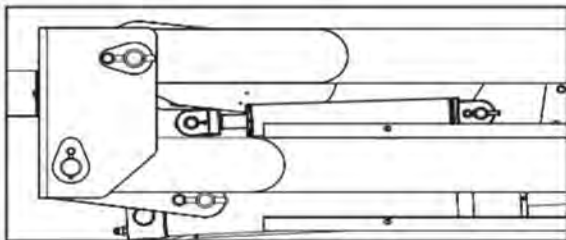
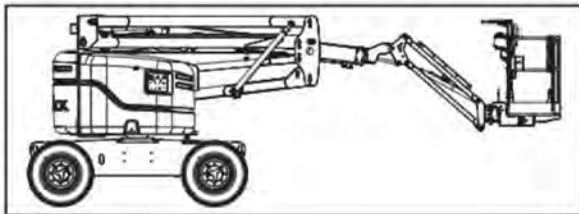

3. Turn the main disconnect switch to the off position . Lock the switch to prevent unauthorized use during this procedure.



NOTE

Ensure all components are secured before lifting or removing them.

4. Using straps, secure the main boom on suitable lifting equipment such as a crane.

5. Secure the master cylinder with straps. See below for an example.



⚠ CAUTION

Label all electrical cables and hydraulic hoses before removal

⚠ CAUTION

To prevent hydraulic system contaminations, cap all hydraulic hoses and fittings after removal.

6. Remove the hydraulic hoses and fittings on the master cylinder. Replace any worn or damaged components.
7. Disconnect the master cylinder from the main boom by removing the connecting pin, see below. Set all parts aside for reuse.

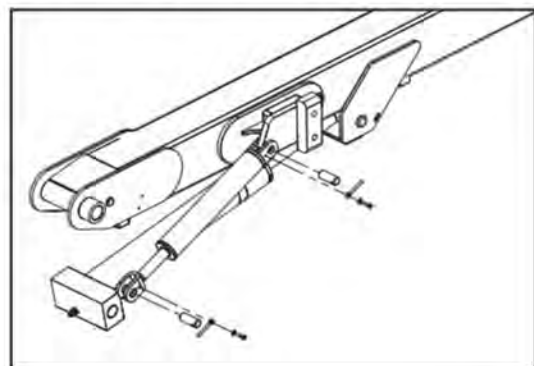

8. Install the new master by installing the cylinder pins as shown above. Secure the keeper pin and the bolt with Loctite 242 (Blue) or equivalent.
9. Install the hydraulic hoses and fittings on the master cylinder.

5.3-6 Limit Switch Locations

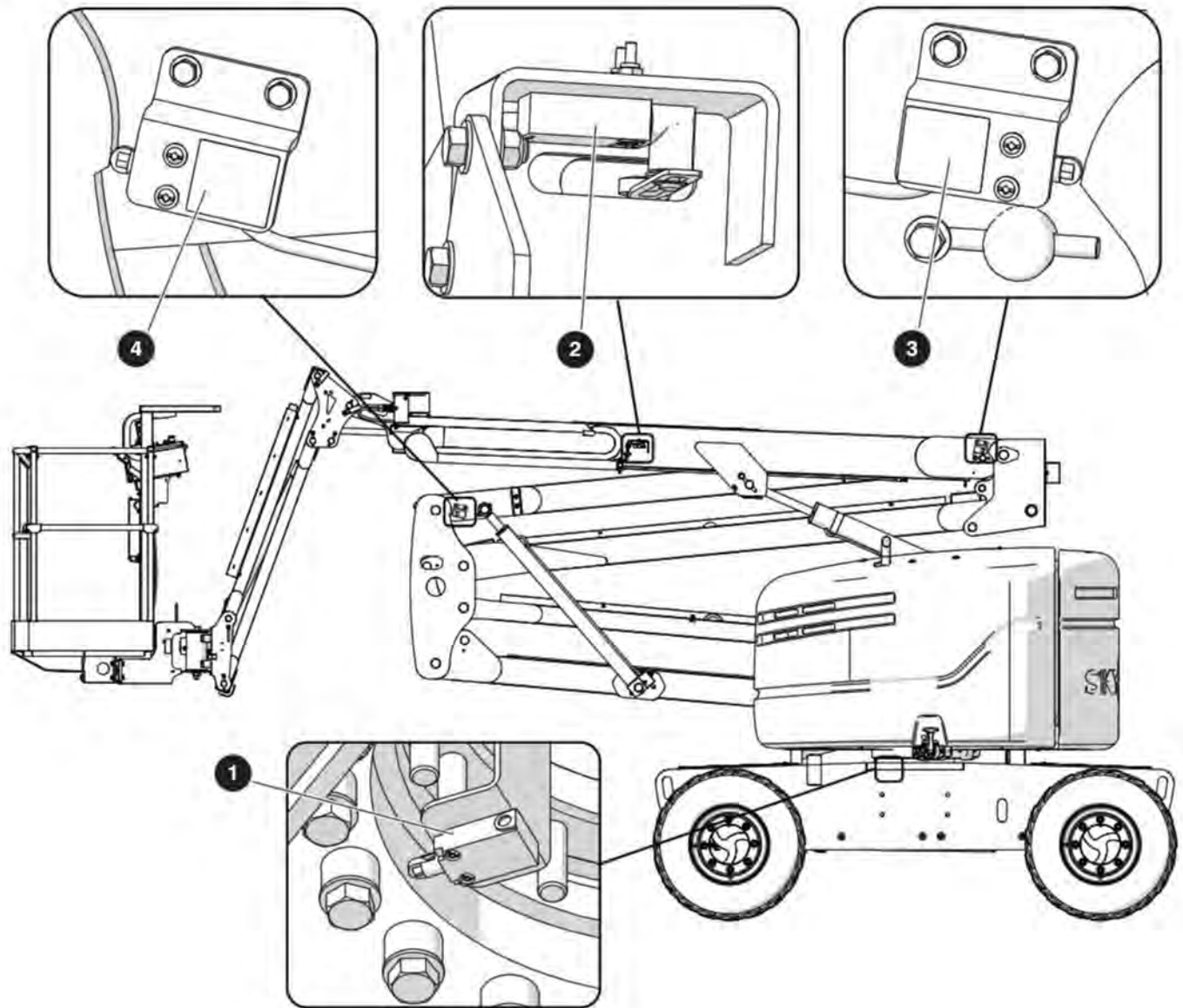

- ❶ Limit Switch LS1 - Direction Sensing
- ❷ Limit Switch LS2 - Fly Stowed (high speed cut-out)
- ❸ Limit Switch LS3 - Main Boom (high speed cut-out)
- ❹ Limit Switch LS6 - Riser Stowed

5.4 Turret

5.4-1 Check and Replace the High Pressure Filter

1. Start the engine from the base control console.
2. Inspect the filter restriction indicator gauge **1**. The filter should operate with the gauge pointing to the green area. If it is in the red area, the filter needs to be replaced.
3. To replace the filter, turn the engine off.
4. Place a suitable container under the filter.

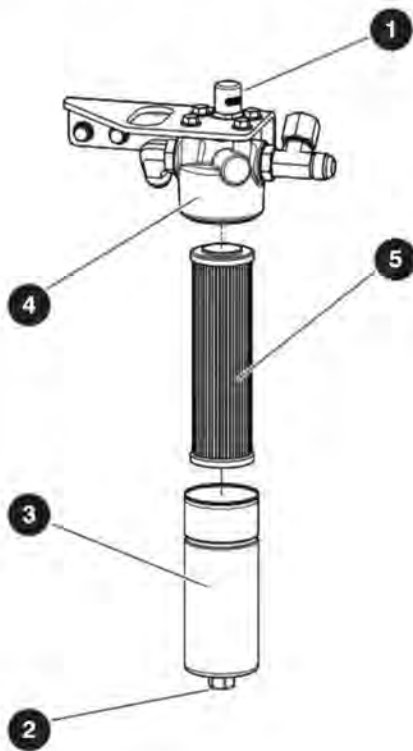

5. Using a 30 mm box wrench on the filter housing nut **2**, loosen the filter housing **3** and remove it from the filter head **4**.
6. Remove the filter element **5** from the filter head and install a new high pressure filter element.
7. Apply hydraulic oil to the o-ring on the high pressure filter housing.
8. Reinstall the housing, screwing it in fully, then backing it off by one quarter turn.

5.4-2 Turret Rotation Gear Bolt Torque Sequence

⚠ WARNING

Maintaining proper torque is essential to safe MEWP operation. Improper bolt torque could result in an unsafe operating condition and component damage.

1. Set the torque wrench to 115 Nm (85 ft-lb) and tighten the mounting bolts in a criss-cross pattern sequence.

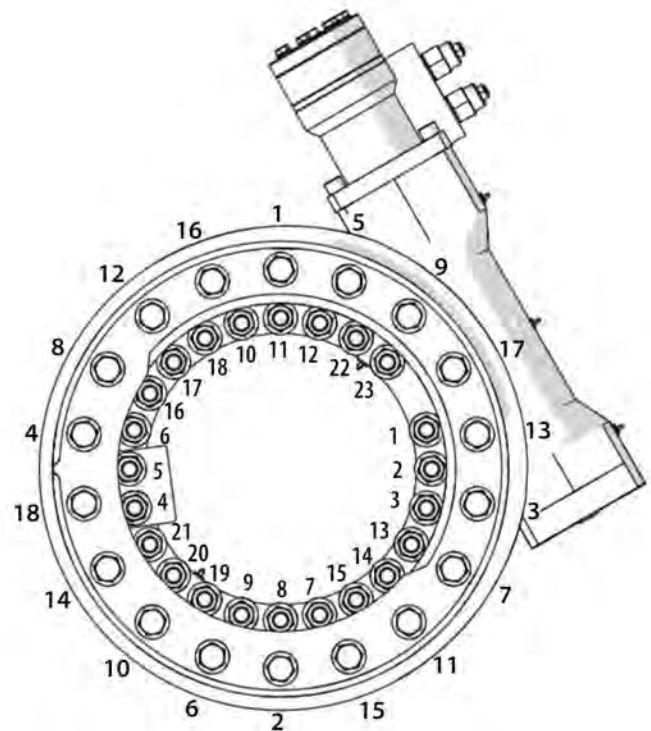

2. Set the torque wrench to 230 Nm (170 ft-lb) and tighten the mounting bolts with the same sequence.

5.4-3 Electronic Tilt Switch Setup Procedure

Tilt Switch Replacement

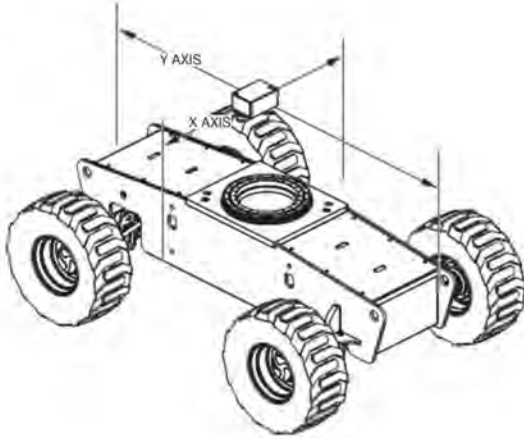

1. Park the MEWP on a firm level surface.
2. Disconnect the tilt switch from the 4 pin connector.



NOTE

Make sure the part number of the old tilt switch and new tilt switch are the same.

3. Remove the old tilt switch from the mount.

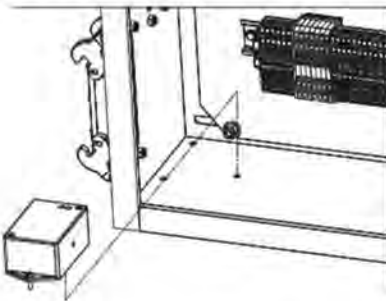

4. Install the new switch on the mount and connect the switch plug to the 4 pin connector.



NOTE

The tilt circuit is only powered when the controls are powered up.

5. Turn the main disconnect switch to the ON position.
6. Turn the base/off/platform key switch to the base position.

7. Pull out both emergency stop buttons.
8. Verify the switch is powered (red or green LED will be solid).

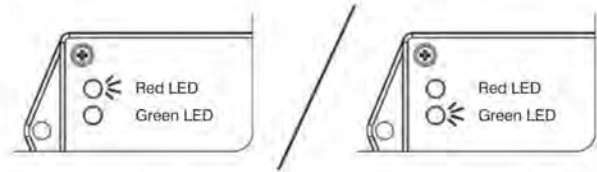

9. Program the tilt switch:
 - a. Press and release the set to zero button 3 times. Observe LED flash codes as shown below.

- b. Only the red LED will blink for 4 seconds.

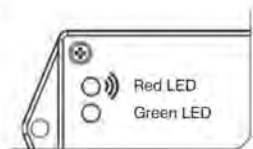

- c. Both LEDs will flash for 1 second. Results: The switch is learning the new zero position.

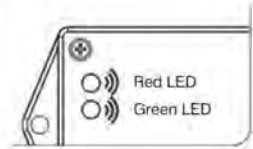

- d. Both LEDs will turn on solid for 1 second. Results: The new zero position has been learned.

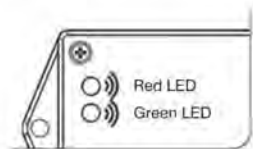

- e. The green LED will flash and then the red LED will turn on solid for 2 seconds. Results: The switch is verifying the new zero position.



- f. Only the red LED will blink for 4 seconds.



10. Turn the main power disconnect switch to the off position.
11. Push in the emergency stop buttons.

Reprogramming the Existing Tilt Switch

Light Indicators The set to zero button is located on this face next to the harness

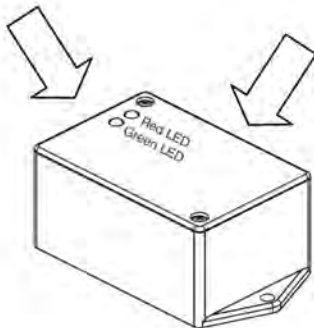

NOTE

The tilt circuit is only powered when the controls are powered up.

1. Turn the main disconnect switch to the ON position .
2. Turn the base/off/platform key switch to the base position.
3. Pull out both emergency stop buttons.
4. Verify switch is powered (red or green LED will be solid).

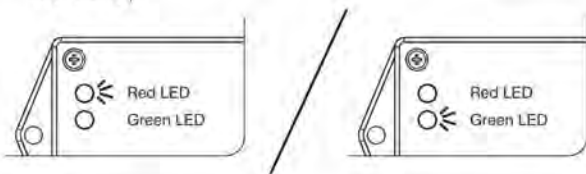

5. Reprogram the Tilt Switch

- a. Press and hold the set to zero button for 5 seconds.
Results: Both LEDs will be OFF.

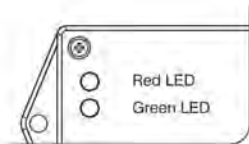

- b. Both LEDs will flash.



IMPORTANT

Step “c” must be completed within a 5 second period, or the switch will automatically exit program mode and return to normal operation using the previously stored data.

- c. Press and release the set to zero button 3 times.
- d. If the 5 second period has expired prior to completion, repeat steps “a”, “b” and “c”.

- e. Observe program delay / stabilization time (only the red LED will blink for 4 seconds).

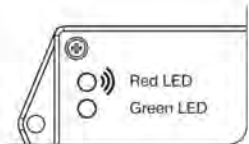

- f. Both LEDs will flash for 1 second.
Results: The switch is learning the new zero position.

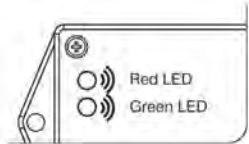

- g. Both LEDs will turn on solid for 1 second.
Results: The new zero position has been learned.

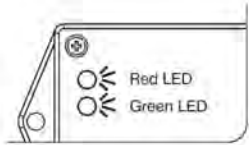

- h. The green LED will flash and then the red LED will turn on solid for 2 seconds.
Results: The switch is verifying the new zero position.

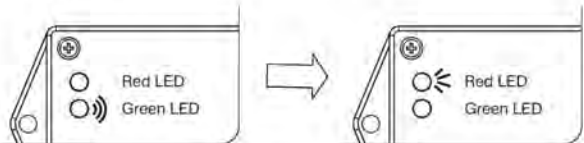

- i. The green LED will turn on solid.
Results: The switch is ready for normal operation.

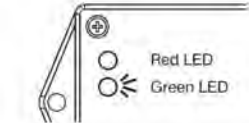

6. Turn the main power disconnect switch to the off position ○ .
7. Push in the emergency stop buttons.
8. Proceed to [Verify Tilt Circuit](#).

Verify Tilt Circuit

Light Indicators

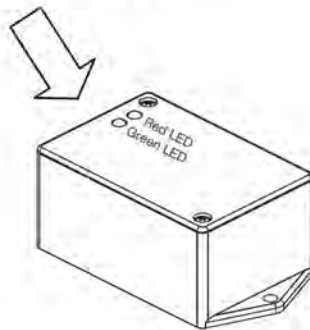

Operations of the Tilt Switch

The following describes the LED's and what they indicate.

Green LED	Illuminated whenever both tilt axes are within the specified degrees of the zero/ home learned position. Flashes when transitioning in or out of tilt angle limits, but built in time delay has not fully occurred.
Red LED	Illuminated whenever tilt on one or more axes is more than the specified degrees out from the zero/ home position.
Green & Red LED	On together, no blinking when fault detected.

5.4-4 Battery Replacement

1. Turn the main power disconnect switch to the off position.

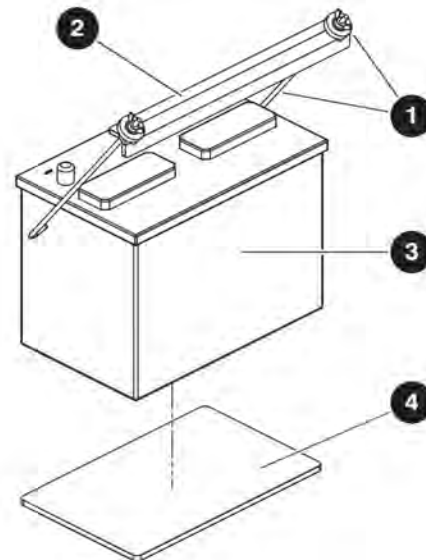

2. Remove the positive and negative connectors from the batteries.
3. Remove the battery retainer bracket nuts, washers, and j-hooks ①.
4. Remove the bracket ②.
5. Remove the batteries ③.
6. Replace the battery pad ④ if needed.
7. Replace the batteries and secure them with the bracket, j-hooks, washers and nuts.
8. Clean the terminal posts and clamps of the batteries, and apply acid-free and acid-resistant grease.
9. Re-connect the batteries with the positive and negative connector cables (ensure the clamps make good contact).

5.5 Diesel Engine

Maintaining the engine components is essential to good performance and service life of the MEWP.

5.5-1 Replace Engine Oil and Filter

Periodic replacement of the engine oil and filter is essential to good engine performance.



NOTE

Warm the engine to normal operating temperature before starting this procedure.



CAUTION

Beware of hot engine components and hot oil. Contact with hot components may cause severe burns.

1. Turn the engine off.
2. Place a suitable container under the engine oil drain.
3. Remove the oil drain plug and allow all engine oil to drain into the container.



WARNING

Dispose of oil in accordance with local and federal regulations.

4. Install the oil drain plug with a new seal ring and tighten it firmly.
 5. Remove the oil filter and catch any escaping oil.
 6. Clean inside the filter head.
 7. Add clean engine oil to the oil filter.
 8. Apply a thin layer of engine oil to the new oil filter gasket.
 9. Install the filter and tighten it by hand.
 10. Clean up any oil that may have spilled during this procedure.
 11. Refill the engine with new oil. Refer to [2.13 Fluids](#).
 12. Start the engine from the base control console and allow the engine to run for 30 seconds, then shut off the engine.
13. Check for oil leakage.
 14. Check the engine oil level on the dipstick and add oil if needed.

5.5-2 Replace the Fuel Filter

1. Close the fuel shut-off valve.
2. Place a suitable container under the fuel filter.
3. Remove the fuel filter and catch any escaping fuel.

WARNING

Dispose of fuel in accordance with local and federal regulations.

4. Clean any dirt from the filter carrier sealing surface.
5. Apply a thin layer of oil or diesel fuel to the rubber gasket of the new fuel filter.
6. Install the fuel filter and tighten it by hand, then tighten the filter cartridge with a final half-turn.
7. Clean up any fuel that may have spilled during this procedure.
8. Open the fuel shut-off valve.
9. Check for fuel leakage.
10. Swing the engine tray back to its original position.
11. Reinstall the engine tray bolt.

5.5-3 Replace the Air Filter

Engine specifications require that this procedure be performed more often if dusty conditions exist. Refer to the engine manual.

CAUTION

Perform this procedure with the engine off.

1. Remove the mounting fasteners from the air filter canister, and remove the end cap.
2. Remove the filter from inside of the canister.
3. Clean the inside of the canister and gasket with a dry cloth.
4. Insert a new filter into the canister.
5. Reinstall the end cap.

5.5-4 Check the Engine Belt

The MEWP will not operate properly with a loose or defective belt. Continuous usage may cause component damage.

WARNING

Do not inspect the fan belt while the engine is running. Remove the key to prevent accidental operation.

1. Inspect the engine belt for:
 - cracking
 - glazing
 - separation
 - breaks
2. For correct tension of the engine belt, refer to the engine manual.

5.6 Hydraulic Tank

Maintaining the hydraulic components and hydraulic oil at the proper level are essential to the good performance and service life of the MEWP.

5.6-1 Hydraulic Oil Replacement

1. Turn the engine on and allow the hydraulic oil to warm up.
2. Shut the engine off.
3. Place a suitable container under the hydraulic tank.
4. Remove the oil drain plug and allow all of the hydraulic oil to drain into the container.
5. Reinstall the drain plug with a new seal ring and tighten the plug firmly.
6. Refill the hydraulic tank with new oil. Refer to [2.13 Fluids](#).
7. Check for leakage.
8. Clean up any oil that may have spilled during this procedure.
9. Check the hydraulic oil level. The hydraulic oil level should be at or slightly above the fill line on the tank.



NOTE

Refer to your national/local regulations on how to dispose of the used filter and oil.



NOTE

Samples of hydraulic oil should be drawn from the reservoir and tested annually. These samples should be taken when the oil is warmed through normal operation of the system. The sample should be analyzed by a qualified lubrication specialist to determine if it is suitable for continued use. Oil change intervals will depend on the care used in keeping the oil clean, and the operating conditions. Dirt and/or moisture contamination dictate that the oil should be changed more often. Under normal use and operating conditions, the hydraulic oil should be changed every two years. For oil specifications, refer to [2.13 Fluids](#).

5.6-2 Hydraulic Filter Replacement

1. Turn the MEWP off.
2. Place a suitable container under the filter.

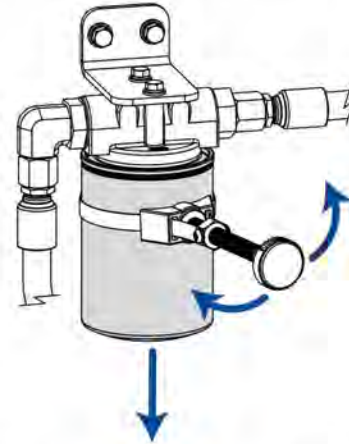

3. Use a filter wrench to remove the filter from the head. Throw out the filter.
4. Apply hydraulic oil to the o-ring on the new filter, and screw the filter into place.
5. Tighten the filter with the filter wrench.



NOTE

Refer to your national/local regulations on how to dispose of used filters and oil.

5.7 Manifold and Hydraulic Pumps

5.7-1 Hydraulic Brake Pressure Adjustment

Maintaining accurate hydraulic brake pressure is important when it comes to safe MEWP operation.

1. Make sure the MEWP is on a firm level surface and is in the stowed position.
2. Locate the BRG port **1** on the side of the brake manifold and remove the cap.
3. Connect a pressure gauge (70 bar/1000 psi) to the BRG port.

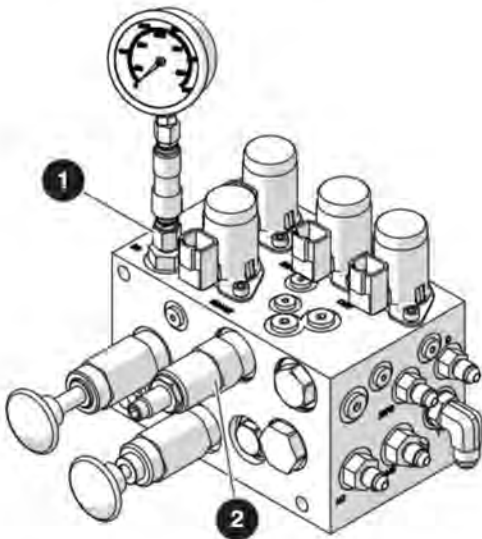

4. Remove the wiring from three valves: differential lock valve wire numbers 165 and 02, axle lockout valve wires 65 and 02, as well as two speed valve wires 45A and 02. Mark the valves to ensure you put the wiring back in the correct positions later.

CAUTION

Failure to remove the wiring may cause damage to components downstream.

5. Locate brake system pressure reducing valve PR1 **2**. Loosen the lock nut and turn the adjustment stem gently clockwise 2 full turns.

WARNING

Valve damage will occur if tightened too much.

WARNING

Make sure there are no personnel or obstructions in the test area and there is sufficient room for forward or reverse travel.

6. Start the engine from the platform control console and extend the boom slightly to achieve low speed drive.
7. Drive the MEWP forward or reverse. The pressure gauge reading should be 34 bar (500 psi). Stop the MEWP. Follow the next steps for adjusting the relief valve pressure, if needed. If no adjustment is required continue to step 10.
8. Turn the adjusting stem on the pressure relief valve **2** 1/4 of a turn at a time clockwise to increase pressure or counterclockwise to decrease pressure. Drive the MEWP forward or reverse, note the pressure and stop the MEWP.
9. Repeat step 9 until brake pressure is achieved (34 bar/500 psi) then tighten the lock nut on brake system pressure relief valve PR1 **2**.
10. Reconnect the wiring in the same position it was removed from in step 4.
11. Test the brake and two-speed functions.

5.7-2 Hydraulic System Relief Valve Adjustment

1. Locate the GP1 port ❶ on the main manifold. Remove the cap.
2. Connect a pressure gauge (345 bar/5000 psi) to GP1 ❶.

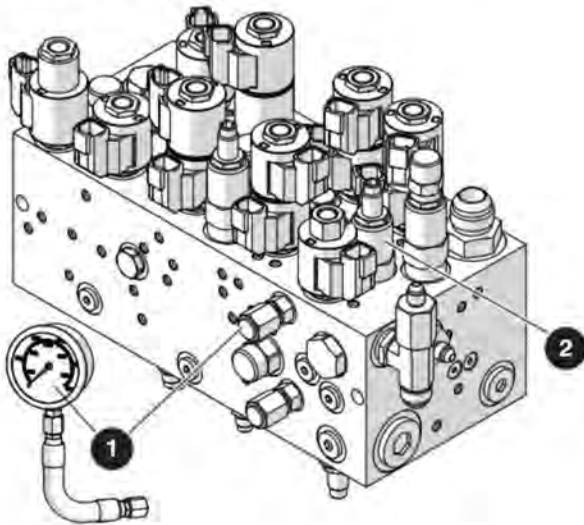

3. Start the engine from the base control console and let it run for 2-5 minutes.
4. Extend or retract the jib fully and then check the reading on the gauge. The pressure should be 214 bar (3100 psi). Follow the next steps for adjusting the pressure, if needed.
5. Locate system relief valve RV6 ❷.
6. Loosen the lock nut on system relief valve RV6 ❷. Turn the adjusting stem clockwise to increase the pressure, and counterclockwise to decrease the pressure.
7. Tighten the lock nut on system relief valve RV6 ❷ once 214 bar (3100 psi) is observed on the gauge. Note: You must steer fully in one direction to activate the pressure reading on the gauge.

5.7-3 Riser Down Relief Valve Adjustment

1. Locate the GP2 port ❸ on the main manifold. Remove the cap.
2. Connect a pressure gauge (345 bar/5000 psi) to GP2 ❸.

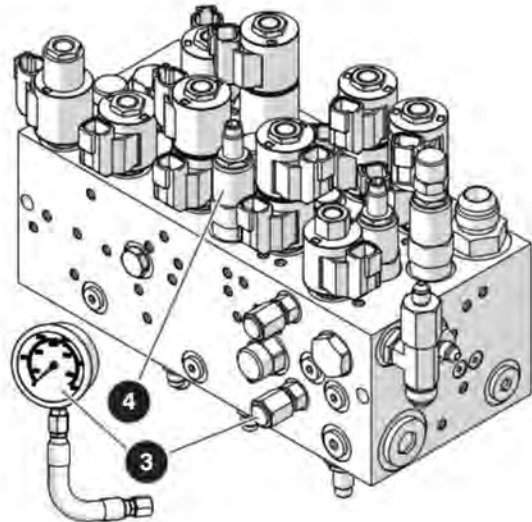

3. Start the engine from the base control console and let it run for 2-5 minutes.
4. Raise the main boom to make sure the platform will not contact the ground.
5. Fully lower the riser and check the reading on the gauge. The pressure should be 190 bar (2750 psi). Follow the next steps for adjusting the pressure, if needed.
6. Locate riser down relief valve RV8 ❹.
7. Loosen the lock nut on system relief valve RV8 ❹. Turn the adjusting stem clockwise to increase the pressure, and counterclockwise to decrease the pressure.
8. Tighten the lock nut on system relief valve RV8 ❹ once 190 bar (2750 psi) is observed on the gauge. Note: You must fully lower the riser to activate the pressure reading on the gauge.

5.7-4 Turret Rotate Relief Valve Adjustment

1. Locate the GP2 port ❶ on the main manifold.
2. Connect a pressure gauge (345 bar / 5000 psi) to GP2.

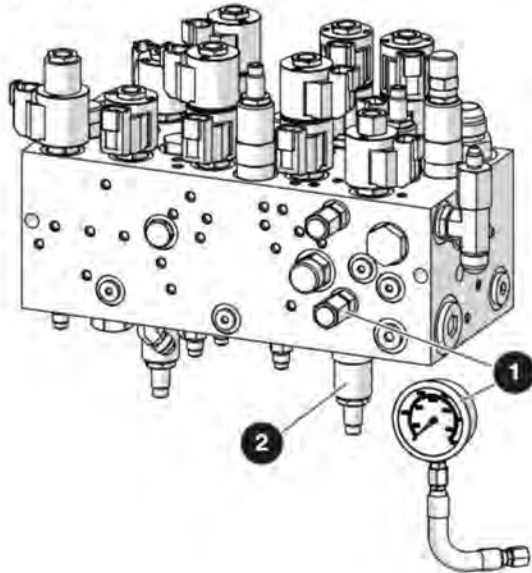

3. Start the engine from the base control console and let it run for 2-5 minutes.
4. Raise the main boom to make sure the platform will not contact the ground.
5. Engage the turret transport lock.
6. Attempt to rotate the turret. The pressure should be 120 bar (1750 psi). Follow the next steps for adjusting the pressure, if needed.
7. Locate the turret rotate relief valve RV7 ❷.
8. Loosen the lock nut on the turret rotate relief valve RV7 ❷. Turn the adjusting stem clockwise to increase the pressure, and counterclockwise to decrease the pressure.
9. Tighten the lock nut on the turret rotate relief valve RV7 ❷ once 86 bar 120 bar (1750 psi) is observed on the gauge. You must activate the turret rotate to obtain a pressure reading on the gauge.
10. Disengage the turret transport lock.

5.7-5 Platform Level Relief Valve Adjustment

1. Locate the GP2 port ❶ on the main manifold.
2. Connect a pressure gauge (345 bar / 5000 psi) to GP2.

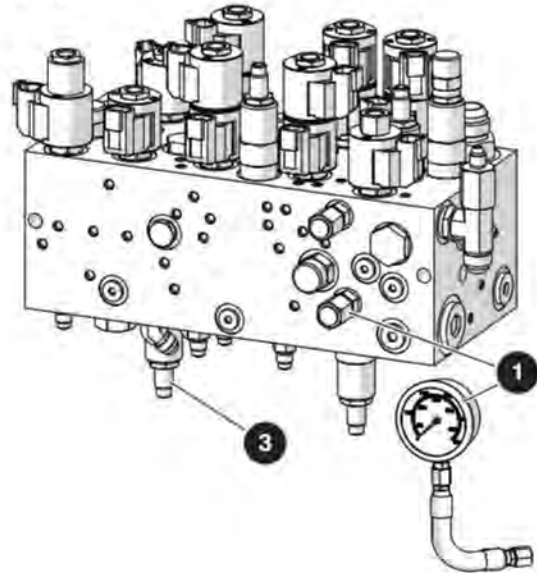

3. Start the engine from the base control console and let it run for 2-5 minutes.
4. Raise the main boom to make sure the platform will not contact the ground.
5. Fully raise or lower the platform level and check the reading on the gauge. The pressure should be 190 bar (2750 psi). Follow the next steps for adjusting the pressure, if needed.
6. Locate the platform leveling relief valve RV9 ❸.
7. Loosen the lock nut on the platform level relief valve RV9 ❸. Turn the adjusting stem clockwise to increase the pressure, and counterclockwise to decrease the pressure.
8. Tighten the lock nut on the platform level relief valve RV9 ❸ once 190 bar (2750 psi) is observed on the gauge. You must fully raise or lower the platform level to activate a pressure reading on the gauge.

5.7-6 Test Charge Pump Pressure on Drive Pump

1. Locate test port TP3 **1** on the drive pump.
2. Connect a pressure gauge 41.5 bar (600 psi) to the test port.

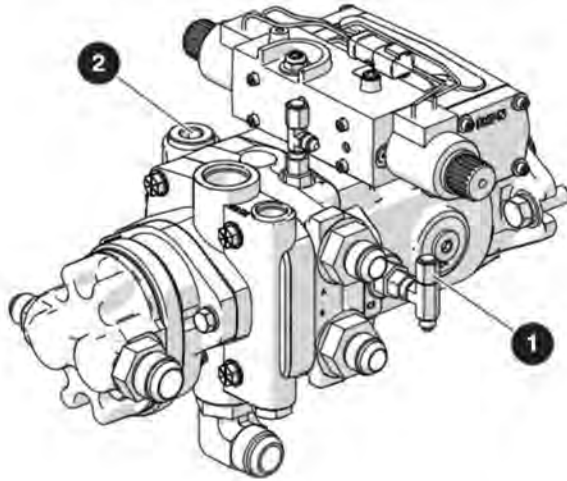

3. Start the engine from the base control console.

WARNING

To protect the gauge, do not activate any controls during this procedure.

4. Check the reading on the gauge. Standard pressure should be 21.5 ± 2 bar (313 ± 31 psi).
5. Replace the charge pump relief valve RV3 **2** if the standard pressure is not achieved.
6. Repeat steps 2, 3, and 4 after the charge pump relief valve is replaced.
7. If the pressure is still not in range, repair or replace the pump as necessary.

5.7-7 Test Forward Drive Pressure on Drive Pump



NOTE

Make sure the charge pump pressure test is completed first.

1. Locate test port TP1 **2** on the drive pump.
2. Connect a pressure gauge (690 bar / 10 000 psi) to test port TP1.

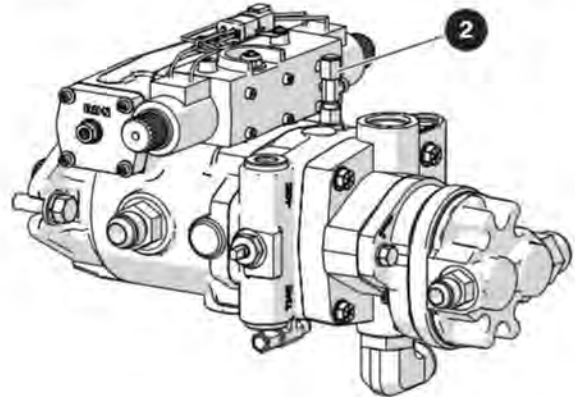

3. Start the engine from the platform control console.
4. Unplug the brake solenoid power cable (26) on the brake valve.
5. Activate the drive function slowly forward with the engine at high speed. The wheels should not turn.



NOTE

Activating the drive function too quickly will stall the engine.

6. Check the reading on the gauge. The standard pressure should be 345 bar (5000 psi).
7. Replace the pump if the pressure is not achieved.
8. Turn the engine off.
9. Remove the pressure gauge from the port, cap the port, and re-plug the brake solenoid power cable.

5.7-8 Test Reverse Drive Pressure on Drive Pump



NOTE

Make sure the charge pump pressure test is completed first.

1. Locate test port TP2 **1** on the drive pump.

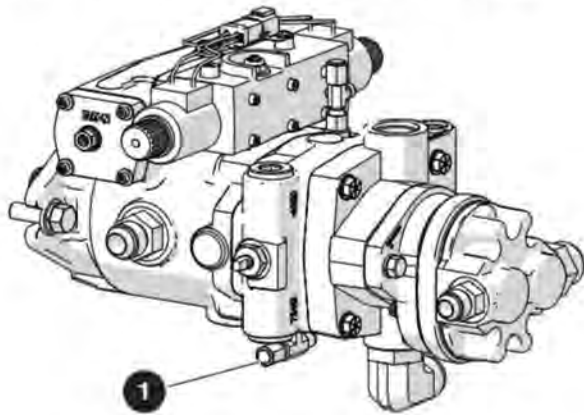

2. Connect a pressure gauge (690 bar / 10 000 psi) to test port TP2.

⚠ WARNING

To protect the gauge, do not activate any controls during this procedure.

3. Start the engine from the platform control console.
4. Unplug the brake solenoid power cable (26) on the brake valve.
5. Activate the drive function slowly in reverse with the engine at high speed. The wheels should not turn.



NOTE

Activating the drive function too quickly will stall the engine.

6. Check the reading on the gauge. The standard pressure should be 345 bar (5000 psi).
7. Replace the pump if the pressure is not achieved.
8. Turn the engine off.

5.8 Axles

5.8-1 Change the Oil in the Axles

1. Place a suitable container under the axle.
2. Remove the fill plug.
3. Remove all three drain plugs to allow the oil to drain into the container.

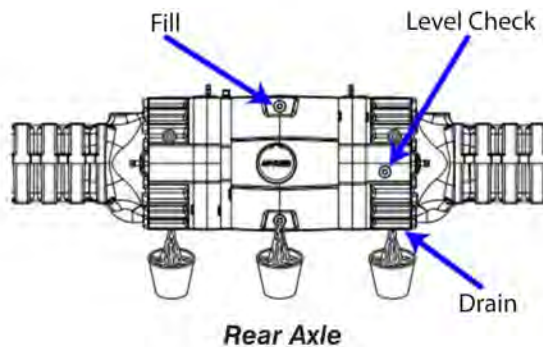
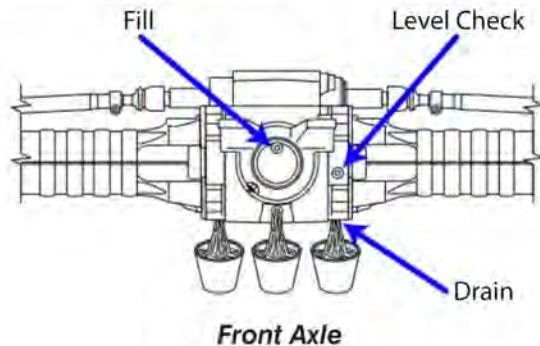

4. Reinstall all of the drain plugs.
5. Remove the check plug.



NOTE

The axle is full when oil is leaking from the check port.

6. Refill the axle with new oil as per specifications. Refer to [2.13 Fluids](#).
7. Reinstall both of the fill and check plugs.

5.8-2 Check the Oil Level in the Torque Hubs

1. Drive the MEWP to rotate the hub until the plug is in the 3 or 9 o'clock position. Shut off the engine.
2. Remove the plug and check the oil level. The oil level should be even with the bottom of the plug hole. Add oil if needed. Refer to [2.13 Fluids](#) for oil specifications.

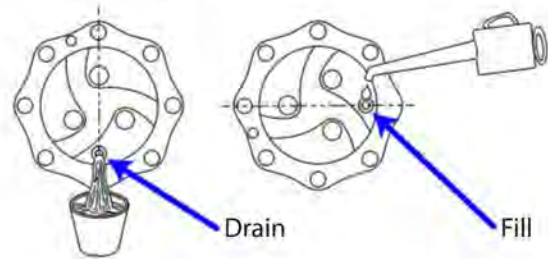

5.8-3 Change the Oil in the Torque Hubs

1. Start the engine and drive the boom until the fill/drain port of one of the hubs is in the 6 o'clock position. Shut off the engine. Place a container under the fill/drain port.
2. Remove the plug and allow all of the oil to drain, watching carefully to avoid spills.
3. Restart the engine and drive the boom until the drain plug is in the 3 or 9 o'clock position. Shut off the engine.
4. Refill the hub with new oil as per specifications. Refer to [2.13 Fluids](#).
5. Repeat the above steps with the other three wheel hubs.

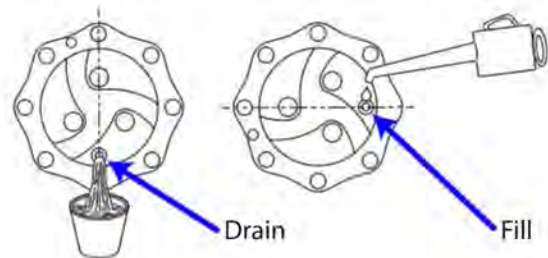

5.8-4 Check the Oil Level in the Axle Gearbox

1. Remove the fill plug **1** from the gear box.
2. Check the oil level. It should be even with the bottom of the fill plug hole. Add oil if needed. Refer to [2.13 Fluids](#) for oil specifications.

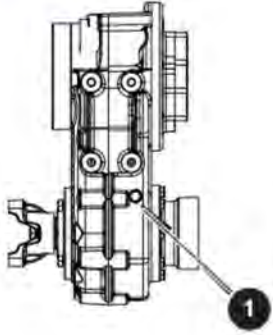

5.8-5 Change the Oil in the Axle Gearbox

1. Place a suitable container under the gearbox.
2. Remove the fill plug.
3. Remove the drain plug to allow oil to drain into the container.

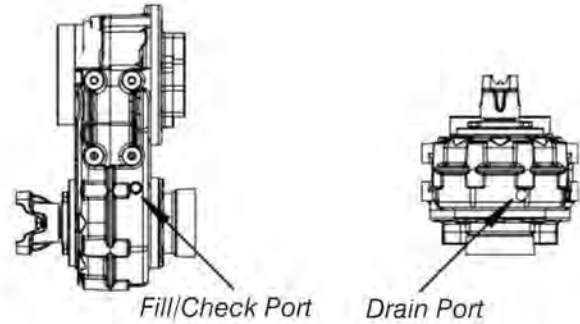

4. Reinstall the drain plug.



NOTE

The gearbox is full when oil is leaking from the check port.

5. Refill the gearbox with new oil as per specifications. Refer to [2.13 Fluids](#).
6. Reinstall the fill plug.

5.8-6 Oscillating Cylinder Bolt Replacement

If upon inspection it is determined that the oscillating cylinder bolts have missing or damaged torque seal, the affected bolts must be replaced. If replacing more than one bolt, do so one at a time to prevent the cylinder from shifting.

1. Remove the affected bolt.
2. Clean the cylinder's corresponding internal threaded hole thoroughly.
3. Replace the removed bolt with a new 01/2"-13 x 1-3/4" grade 8 bolt, applying liquid blue Loctite 242 or 243 to the bottom half of the bolts.
4. Hand tighten the bolt.
5. Torque the new bolt to 108 Nm (80 ft-lbs).
6. Apply a line of torque seal to each new bolt extending from the bolt head over the washer and to the chassis wall.



5.8-7 Oscillating Cylinder Replacement

⚠ CAUTION

The oscillating axle cylinder weighs approximately 19.5 kg (43 lb), so a second person to assist with the removal and replacement would be helpful.

1. Wedge a block of wood between the front axle and the chassis, to prevent the axle from oscillating during the procedure.

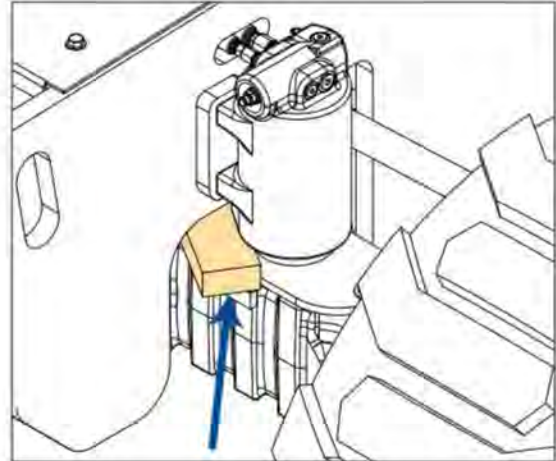

2. Remove and set aside the base cover from the oscillating axle end of the chassis.

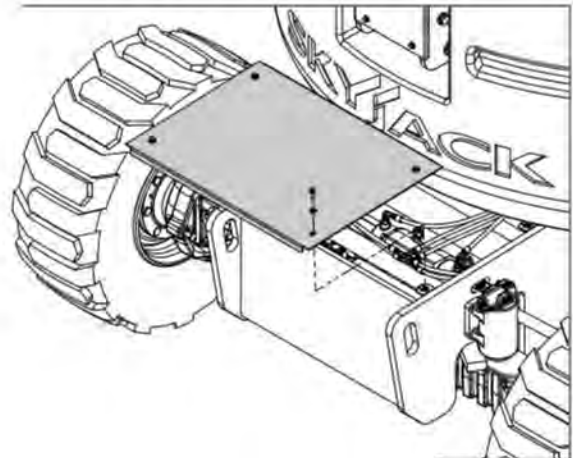

3. With a rag in hand to catch any leaking oil, slowly loosen the bleeder screw to release any trapped air within the cylinder, then tighten it again. Slowly loosen the oscillating axle cylinder hoses to release the pressure, then disconnect them fully, being sure to plug the hose ends.

- Remove and set aside the cylinder fittings, ensuring they stay clean.

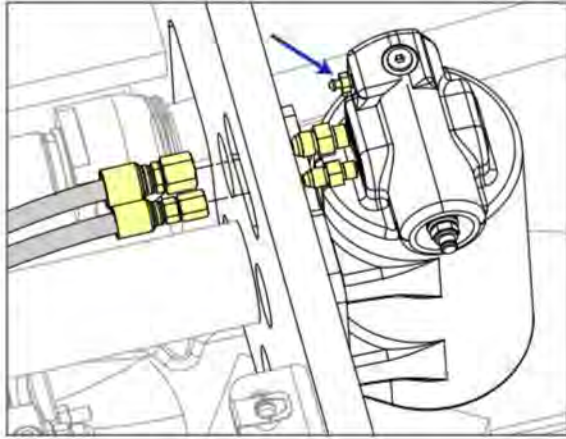

- Remove and throw away the bolts and washers securing the cylinder to the chassis. Lift the cylinder away.
- Lift a new cylinder into place and install new bolts (1/2"-13 x 1-3/4" grade 8) and 1/2" hardened washers, applying liquid blue Loctite 242 or 243 to the lower half of the bolts before installing them. Hand tighten the bolts.

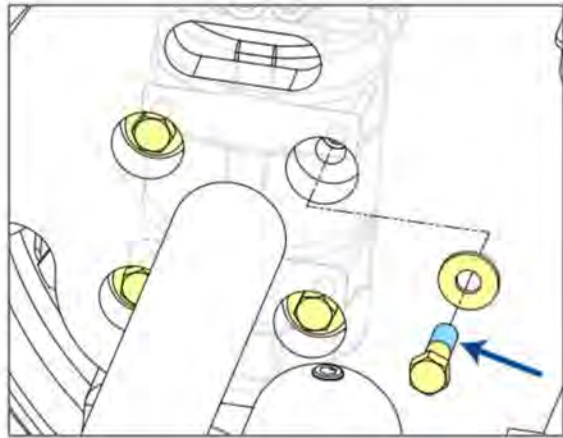

- Adjust the oscillating cylinder position until there is continuous contact between the cylinder mounting surface and the mounting plate, and between the mounting plate and the cylinder shoulder, with no gaps. Torque the bolts to 108 Nm (80 ft-lbs).

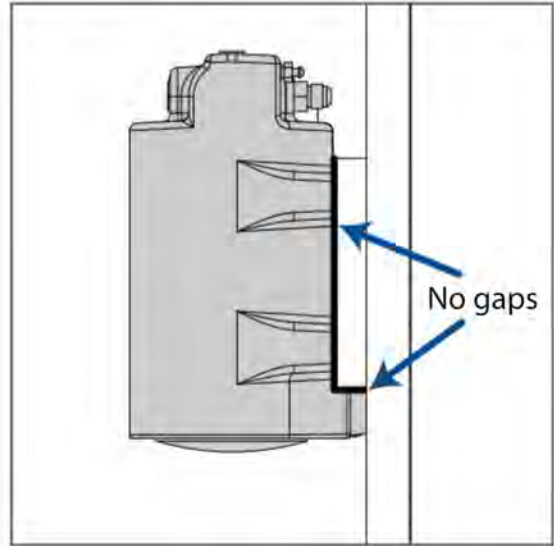

- Apply a line of torque seal to each bolt extending from the bolt head over the washer and to the chassis wall.



9. Reinstall the cylinder fittings, torquing the larger one to 33 Nm (24 ft-lb) and the smaller one to 20 Nm (15 ft-lb).
10. Remove the plugs and reconnect the hoses to the cylinder fittings, torquing the larger hose end to 28 Nm (21 ft-lb) and the smaller hose end to 16 Nm (12 ft-lb).
11. Reinstall the base cover and remove the block of wood.
12. Turn the engine on and let it run for a few minutes to pressurize the cylinder, then turn it off again.
13. Check the oil level using the hydraulic tank sight gauge. Add more hydraulic oil if needed.
14. Bleed the cylinder (refer to the next procedure).

5.8-8 Bleed the Oscillating Axle Cylinders

If the axle oscillation system is not operating properly, the stability of the MEWP is compromised and it may tip over.

Items you will need before starting:

- oil container
- hose (to reach from bleeders to bucket)

1. Locate a bleeder on either side of the oscillating axle cylinder.
2. Connect a hose to the bleeder nipple.
3. Start the engine and slowly open the bleeder to allow the oil to flow in a continuous stream.
4. Close the bleeder.
5. Repeat the procedure with the other oscillating axle cylinder.

5.8-9 Test the Oscillating Axle Cylinders

1. Extend the fly boom 30 cm (1 ft) while on a firm, level surface.
 - **Result:** The steer axle should be locked.
2. Drive one of the steer tires up onto a 15 cm (6") block or curb.
 - **Result:** An appropriate tilt of the MEWP chassis should occur.

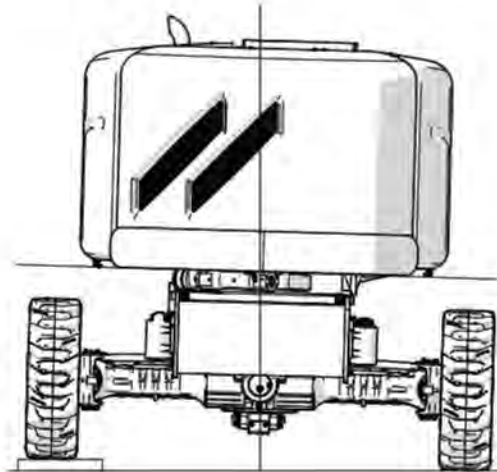

3. Retract the fly boom while in tilt position.
 - **Result:** The steer axles should unlock and the MEWP chassis should level itself to the ground.

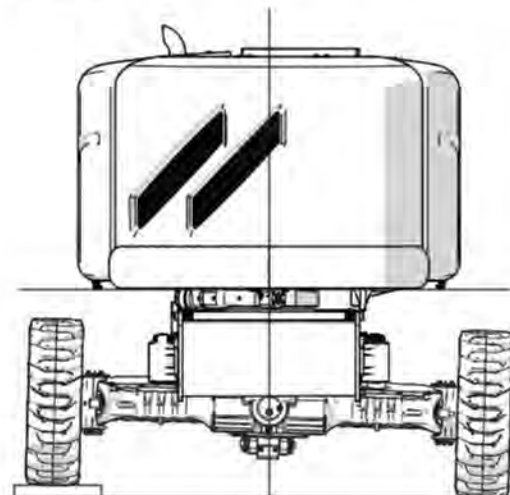

5.8-10 Pin Brake Adjustments

1. To manually release the brake give a light blow to the external ring of the check unit.

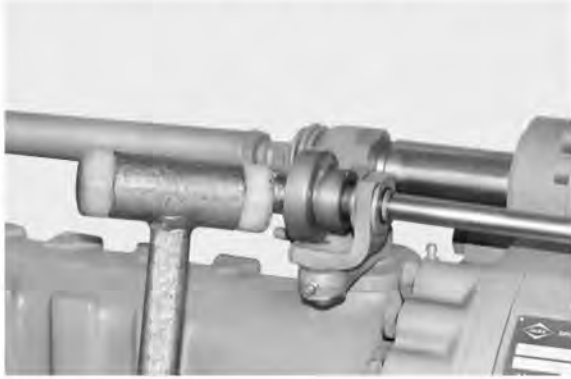

2. To adjust the idle elimination loosen jam nut and back out adjustment stem a few turns.



3. Apply a 2lb. force (1Kg) in the direction of brake application and turn adjusting stem so that it touches the stop.



4. Tighten the Jam nut. Repeat this procedure for the other side.



5. On the Cylinder side ensure that there is some clearance between the cylinder and the lever "A" with the lever against the stop.

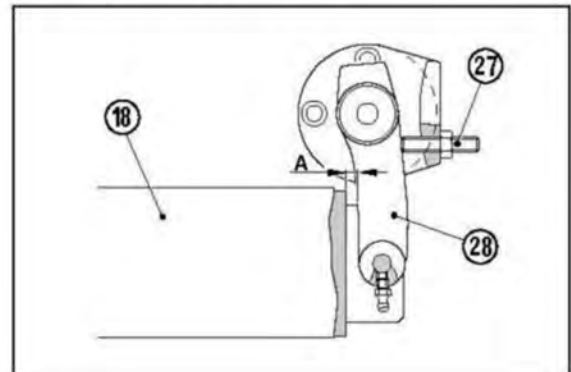

6. Introduce pressure into the cylinder and ensure that the check unit engages.



- Release the pressure from the cylinder and check that the rod returns and stops in a position where it projects out from the cylinder head by 5 mm (3/16").

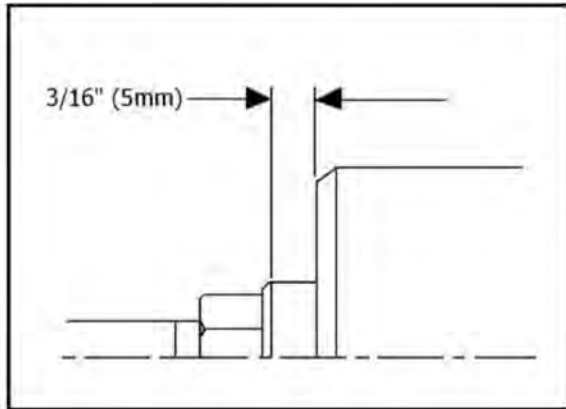

- If adjustment is needed loosen the jam nut, pressurize the cylinder and turn the adjustment stem. Repeat step 7 and tighten jam nut when correct adjustment is obtained.



9.

5.8-11 Brake Inspection

- Remove the oil level plug from one of the braking axle arms, as shown below.

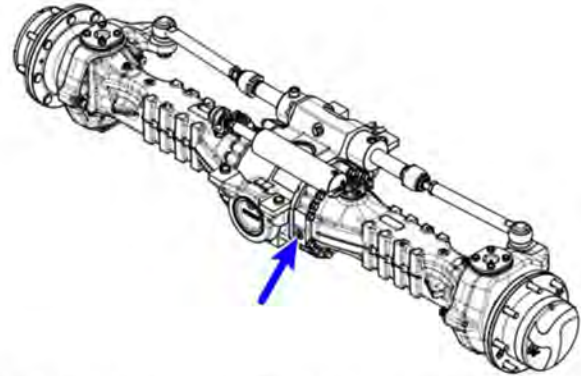

- Insert a 4.5 mm feeler gauge into the drain port.

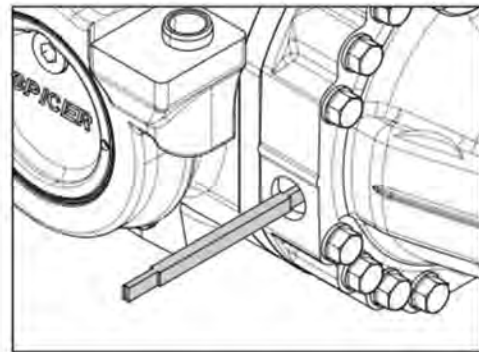

- Use the gauge to check the gap between the disks (A). The minimum distance allowed is 4.5 mm. Reinstall the oil level plug.

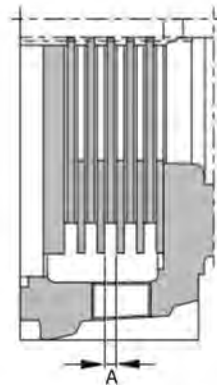

- Repeat the inspection on the other axle arm. If the gap is smaller than 4.5 mm between the disks of either arm (i.e. the gauge doesn't fit), the brake disks must be replaced on both arms.

5.8-12 Axle U-Bolt Torque

Replace the u-bolts and nuts every time you replace or remove an axle, or when a u-bolt has been loosened for any reason.

Refer to the parts manual for the u-bolt, flat washer, and nut part numbers.

1. If applicable, set the axle in place under the chassis.
2. Put a new u-bolt through the holes in the mounting bracket. Place flat washers over the bolts. Install two new nuts on the ends of the bolt. Finger-tighten the nuts.
3. Repeat with the other three u-bolts and nuts.

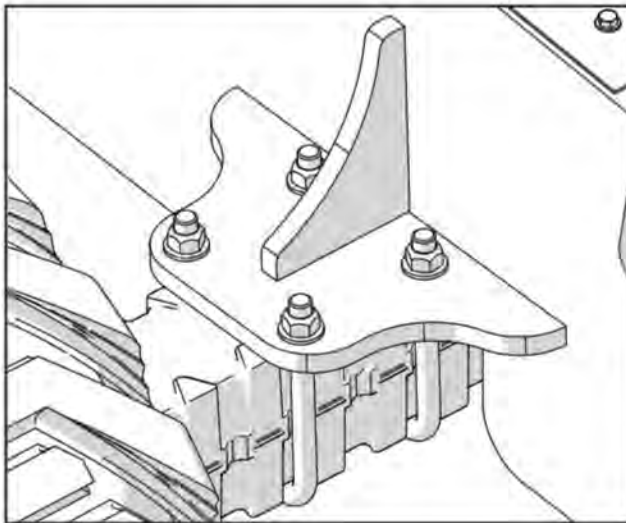

4. Gradually tighten the nuts evenly so the same amount of bolt thread shows above all 4 nuts. Use the sequence shown below.
5. Use the same sequence to torque the nuts to 290 Nm (214 ft-lb).

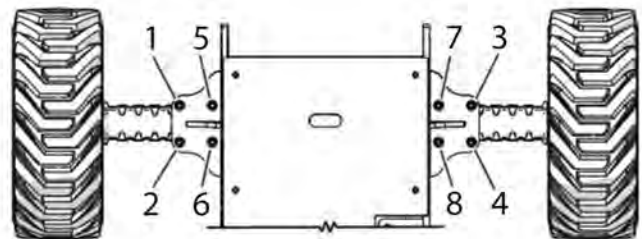
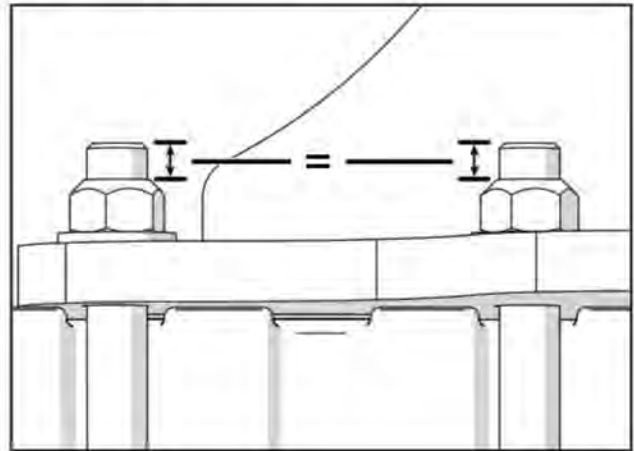

5.9 Grease Points

Maintaining proper lubrication is essential for good performance and service life of the MEWP. If the bearing and gear of the MEWP are improperly greased, it could result in component damage.

5.9-1 Grease the Turret Ring Gear

1. Open the control side cowling, and locate the turret ring gear grease fitting **1** under the bottom right corner of the base control box.
2. Pump grease into the fitting, and continue pumping until new lube appears continuously around the grease seal lip of the ring gear.
3. Rotate the turret in increments of 10 to 13 cm (4 to 5 inches) at a time, and repeat step 2 until the entire bearing has been greased.
4. Pump grease into the three grease fittings on the outside of the worm gear motor **2**.

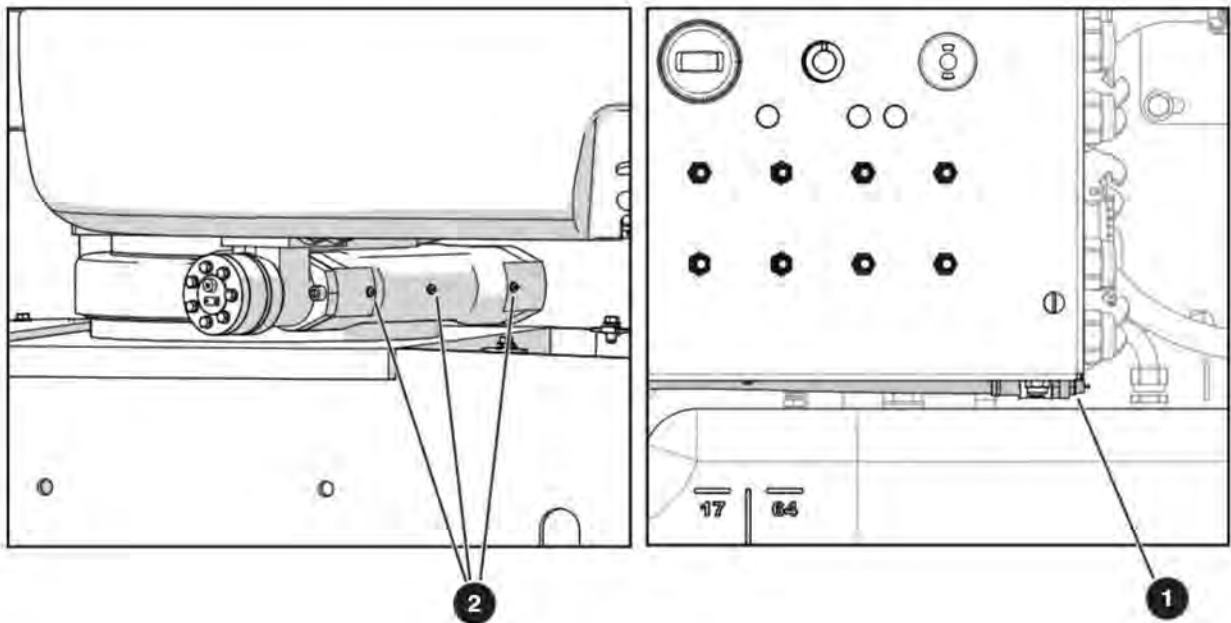

5.9-2 Grease the Axles

1. Open the axle cover plates and locate the grease fittings.
2. Pump grease into the grease fittings.

5.9-3 Grease the Drive Shaft

1. Locate the grease fittings on the drive shaft u-joints, and pump grease into the fittings.

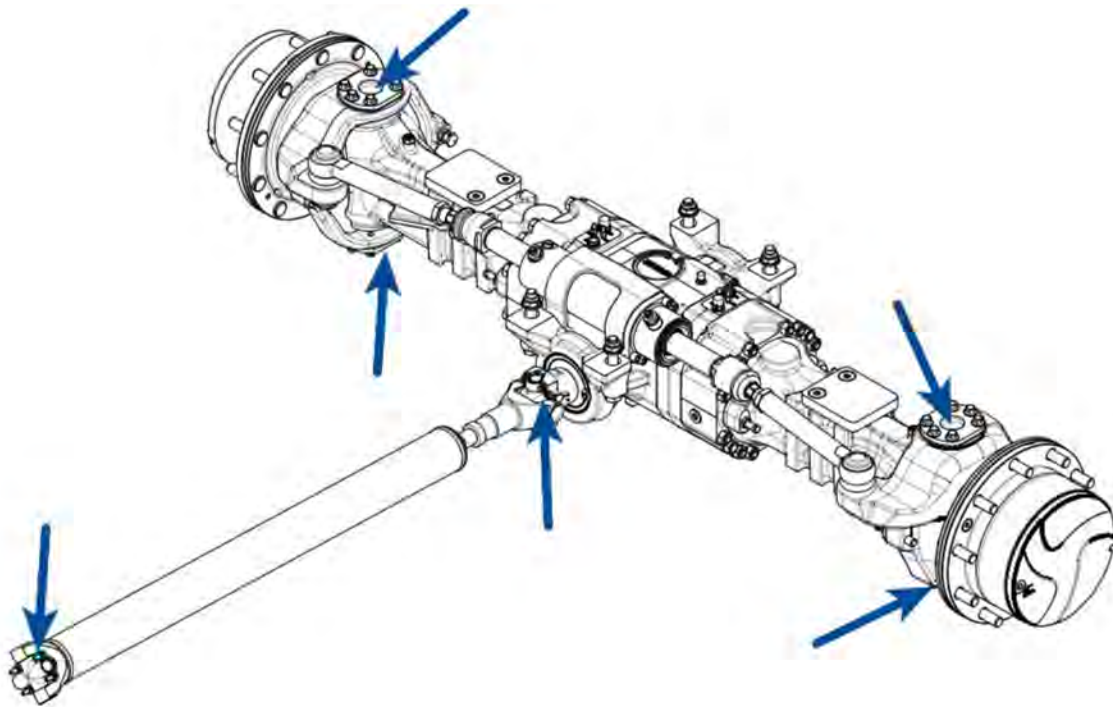

SKYJACK

www.skyjack.com